



# 2 0 0 1

## WINNING PROJECTS

AISC's National Engineering Award's Program provides national recognition to structural engineering excellence and innovation in steel-framed building projects.

To be eligible for an award:

- A significant part of the framing system must be steel wideflange structural shapes or hollow structural sections;
- Building construction must have been completed between January 1, 1996 and December 31, 1999; and
- Projects must be located in the U.S., Canada or Mexico.

Projects were judged on the following criteria:

- Creativity in response to the owner's and architect's program;
- Application of new or innovative technology in areas such as connections, gravity systems, lateral load resisting systems and fire protection;
- Structural efficiency; and
- Significance of engineering achievement.

This year's jury members were:

- David L. Platten, Principal, Walter P. Moore and Associates, Inc.
- Robert Power, Vice President, Heery International, Inc.
- Stanley L. Welton, Principal, Martin/Martin, Inc.

### US \$100M and above

#### **NATIONAL WINNER**

##### **Experience Music Project**

Seattle, WA

Skilling Ward Magnusson  
Barkshire Inc.

#### **MERIT AWARD**

##### **New International Terminal**

San Francisco, CA

Skidmore, Owings & Merrill LLP

### US \$25M or greater, but less than US \$100M

#### **NATIONAL WINNER**

##### **McNamara Alumni Center, University of Minnesota Gateway**

Minneapolis, MN

Meyer, Borgman and Johnson, Inc.

#### **MERIT AWARD**

##### **Gateway Village Project - Block 800**

Charlotte, NC

Stanley D. Lindsey  
and Associates, Ltd.

### US \$10M or greater, but less than US \$25M

#### **NATIONAL WINNER**

##### **PDX Canopy and Pedestrian Bridges**

Portland, OR

KPFF Consulting Engineers

#### **MERIT AWARD**

##### **Indoor Football Practice Facility**

Chicago, IL

Tylk Gustafson Reckers  
Wilson Andrews, LLC

#### **MERIT AWARD**

##### **Eiffel Tower II**

Las Vegas, NV

Martin & Associates

### Up to US \$10M

#### **NATIONAL WINNER**

##### **Oneida Junior/Senior High School**

Oneida, NY

Klepper, Hahn & Hyatt

#### **MERIT AWARD**

##### **Woodstock Branch Library**

Portland, OR

Degenkolb Engineers



# EXPERIENCE

## Music Project

Seattle, Washington

*Jon D. Magnusson, P.E., S.E.*

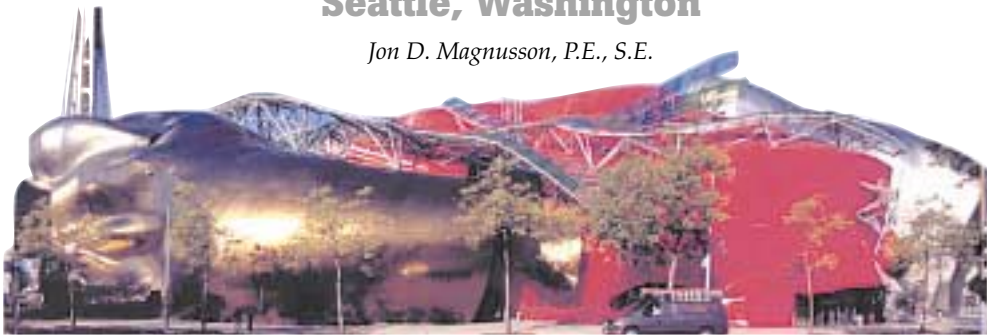

Called “eye-poppingly spectacular” and “frozen music,” the free-form swoops and curves of Paul Allen’s 140,000 sq. ft. Experience Music Project (EMP), an interactive music museum, define a new standard of creativity. Yet it was the development of an entirely new structural system and the creation of the project in total 3D that really positions EMP at the forefront of engineering technology.

To truly comprehend the level of effort and innovation required, it is first necessary to understand the evolution of the project. Paul Allen, Microsoft’s co-founder, and his sister Jody Patton (EMP’s executive director), were devoted to creating a facility dedicated to the history of rock and roll. The original concept was a small tenant improvement in an existing one-story

building on the grounds of the Seattle Center (home of the 1962 World’s Fair). However, it quickly became apparent that Allen’s vision was on a much grander scale. He and Patton established the building program and then charged renowned architect Frank O. Gehry with taking the project into uncharted artistic realms.

Using a series of block and massing models, Gehry first determined positioning on the site and the basic spatial and functional concept. Then, starting with sketched visions and proceeding to carefully crafted hand-built models, Gehry’s office created the look and feel of EMP. Once satisfied, a digitizing tool captured the model’s geometric coordinates into sophisticated 3D software. Visually refined, it now remained to figure out how the structure could be built.

While Gehry’s Bilbao Guggenheim project looks similar to EMP, it is comprised primarily of “ruled surfaces.” This means that the structures can be framed conventionally with straight members and the skin warped to fit the design intent. EMP’s constantly changing curvature in all directions prevented this approach. Yet the project’s success rested on the development of a structural system with a defined load path that was able to adapt to the curves, span long distances, resist earthquakes and, of course, be constructable.

Ultimately, after exploring many different structural concepts, close examination of Gehry’s vision revealed an almost “organic” formation, with each of the six building elements having an axis and orientation resembling “spines.” This led to the idea of drawing upon the human form, with the



torso shaped by a skeleton of ribs covered by skin, similar to building techniques used in the aviation and boat-building industries. The solution had been found in an approach utilizing continuously curving ribs and a skin.

This totally new structural system incorporates 240 individually curving steel beams, covered by mesh, then a 5" layer of shotcrete over welded wire fabric. This creates each major gallery element as a steel-stiffened concrete shell, with the shell resisting earthquake forces while it is held in place, shaped and stiffened by the steel ribs.

The entire structure was then coated with a waterproofing membrane. An elaborate system of 5" diameter steel pedestals of varying lengths attached to the ribs, to support 3,000 panels of steel and aluminum skin (comprised of 21,000 individually shaped shingles).

### **How the Structure Satisfies the Program/Unique and Innovative Characteristics**

It is an indisputable that steel was the key to the engineering solution used to create EMP. No other system examined provided the flexibility, precision, strength and artistic freedom of steel.

The following discussion highlights some of the unique challenges and innovative solutions that went into developing the steel system used for EMP:

### **Complex Invention of "Steel-Stiffened Concrete Shell" Structural System**

A new structural system had to be invented for the free-form visions of Paul Allen and Frank Gehry to become reality. The system had to accommodate EMP's non-symmetrical curvature in all directions.

As various ideas were suggested, it was necessary to analyze them conceptually through how the system would be built to determine feasibility. A number of different concepts were tracked at the same time, and often ideas that had been developed at length would ultimately be rejected. Complicating matters even further, this development of the structural system was undertaken at a time when the nature and material type to be used for the building's skin had not yet been determined.

The ultimate solution, combining steel ribs, a composite concrete shell, and a pedestal support system, was totally unique. Taking its cue from the ribbed construction of airplanes and boats, the idea was applied for the first time ever to a building. By designing each rib with a different geometry, the desired curves and swoops could be captured in place. The steel-stiffened rib system provides the design profession with a new tool in creating what in the past could only be dreamt about.

### **Advanced Application of Computer Technology Ever**

On a typical project, there is no connection between the databases of information used for design and construction; everything is accomplished with two-dimensional drawings. The approach on EMP was groundbreaking: everything was accomplished using one common database. Starting with a hand-created small-scale model and a digitizing tool and continuing through to the comput-



## Engineering Revisited and Modified Every Aspect of Design

While some projects require the development of a single new method or technique, EMP demanded that every single aspect of its structure be invented. This included how the structure was analyzed and designed, how it was shown on the drawings, how it was detailed, how it was erected, how the concrete was formed, placed and finished, etc. Full-scale mock-ups were employed by the project team to test and refine many of these new techniques.

Many of the concepts used for EMP incorporated existing technologies borrowed and enhanced from other disciplines:

- The steel rib system was developed from bridge technology and girder fabrication methods, pushed to the extreme.
- Shape-fitting programs were employed to minimize material quantities by analyzing the “best fit” of multiple curved ribs from a single plate.
- The composite action of the steel ribs and shotcrete shell emulates unibody construction used in the automobile industry.
- The shotcrete shell shot on fine wire mesh was adapted from rock formations in zoo displays.

Even the usually routine parts of design had to be completely rethought. For example, many code provisions define requirements in terms of “wall systems” and “roof systems.” When you look at EMP, it is impossible to determine what is a roof and what is a wall. The roof plan for the EMP building is actually a contour map, with ridges and valleys, not unlike what you would see depicting a mountain range. Routine structural/mechanical coordination items, such as sprinkler lines, took on a whole new complexity when dealing with curved three-dimensional spaces. “No one has built anything like this before,” says Paul Zumwalt, EMP owner’s representative, “It’s essentially a piece of modern sculpture that holds people and meets code.”

ers that ultimately cut the final steel shapes, the entire creation of EMP was accomplished through a series of computer “handshakes.” The geometric data was initially captured in CATIA, a 3D solid-modeling program. The geometry was tested visually on workstation computer screens and physically through the creation of computer-cut models to confirm that it matched Gehry’s intent. That information then became the database for all geometrical control on the project, exchanged electronically from computer to computer, ensuring continuity and facilitating communication of vital information to all team members, including the contractors. While buildings have previously been designed in 3D, never before has the approach been used in such detail to actually construct a building. The geometric data and

model were specifically used in the structure to:

- Provide virtual walk-throughs;
- Perform interference checks;
- Calculate quantity take-offs;
- Perform steel detailing;
- Cut the components of the steel ribs;
- Provide dimensions;
- Set the concrete formwork and embeds;

Define survey points. The project development and execution was so complex that a master flow chart was created early on by architect, contractor and structural engineer to detail the upcoming computer handoffs and required technology. The 28-step chart graphically detailed the programs and interfaces required for execution, so that all team members could ensure that they were technologically prepared to participate.

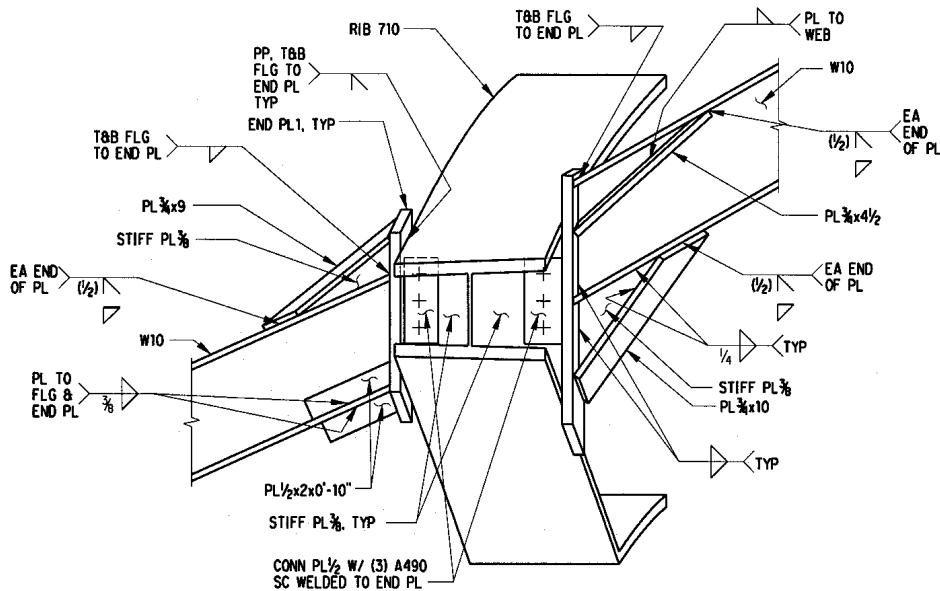

in-place solution, a fish-scale-like glass system and titanium. The system selected utilizes panels of painted aluminum and interference-treated stainless steel (a process that interferes with the natural reflection of the spectrum of light, absorbing selected wavelengths and reflecting the desired color).

### Seismic Complexity

Seattle is in the fourth most hazardous of the five zones identified in the Uniform Building Code. Every aspect of the design needed to address this challenge.

### New Technology = Increased Control

The computerized technology and hand-offs used on EMP produced a phenomenal level of control: e.g., the steel fit-up on the project was better than on a conventional building, even though the design was incredibly more complicated. Application of these technologies to conventional building design will bring about a giant leap forward for the industry. Increased control can produce higher fabrication accuracies, faster erection times, increased efficiencies on takeoffs and materials quantities and 100% coordination between disciplines (using visualization tools that allow the building to be built in virtual space).

### Extremely Strict Tolerances

The very nature of EMP's structure dictated a series of tolerances that were phenomenally strict:

- A sequential analysis of the shotcrete application was performed to analyze the deflected shapes and determine the optimum approach to meet overall building tolerances;
- The geometries of each and every rib had to be smoothed and adjusted based on what could be fabricated from a curvature standpoint;
- Ribs were placed every 10' perpendicular to the each element's "spine" due to the limitations of the load-carrying capacity of the shotcrete mesh;

- The steel ribs were set using 3D laser technology to confirm location and ensure tolerances;
- The size of each individual skin "shingle" was determined through a program that analyzed the buckling capacity of the chosen skin material when warped in two directions

### Geometric Irregularities = Increased Complexity

The geometric irregularity of EMP caused a tremendous increase in the complexity of the design. One example is the computer earthquake simulations performed to determine the required strength and stiffness of the structure. Developing the computer model for a 50-story office building would typically take about one week, with each analysis run lasting 20 minutes. Comparatively, developing the computer model for the EMP structure took three months, with each run lasting over 24 hours.

### Skin Options Analyzed at Length

Obviously, skin options had to be examined not just from a fabrication point of view but also for loading, attachment to the structure, affect on system performance, etc. Options examined were numerous and included a composite concrete-and-terrazzo system shaped with a five-axis milling machine (commonly used to shape the hulls of custom boats), a cast-

### Creating the Future of Building Design and Construction

One of the biggest steps forward on EMP was the level of integration between the computer geometry database and the actual manufacture of the building components. For example, take the creation of the steel ribs, all done with computer-controlled processes. Basically, the steel was literally shaped by the architect's hand, as the original physical model was preserved through a series of electronic "baton passes."

This approach is the way of the future. Ten years ago, CAD was something new and almost experimental. Three-dimensional documentation, such as CATIA, is currently thought to be at the same stage. Yet 3D building design—from start to finish—is the future of the industry. It may be another five or 10 years until it is widely accepted, but the project benefits to be gained by all are amazing: advanced integration, increased team communication and coordination, more accurate takeoffs and estimates, better cost estimating, etc. Every single team member on this project was a pioneer and at the same time a "guinea pig": thought processes had to be modified, new equipment and software developed and problems overcome with this entirely new way of design. While the result, EMP, is certainly thought provoking, the approach itself is pioneering, leading the way for others in the future of building design. In fact,

EMP has been hailed as “benchmark architecture for the millennium.”

### Meeting the Owner's Expectations

Budget, Schedule, and Program Meet Owner's Expectations

It is very difficult to characterize the budget and schedule for EMP, because they remained moving targets dictated solely by the owner's desires. The program was continually expanded, both in terms of content and ambitions. Starting out as a \$6 million tenant improvement project, the project evolved, at the owner's request, to a \$240 million facility. Yet, the structural solution was key to the building's creation, and throughout the process, the system was developed with a focus on both cost and feasibility. While the owner deferred to the architect in terms of design, they had strict expectations for the program space. All of these program requirements were met.

### Owner and Client Intimately Involved Throughout Project

It would have been virtually impossible to create this facility without the intimate involvement of the client and owner. Per Paul Zumwalt, the Owner's Representative, “The daily heroic effort that SWMB performed in the design and construction management phases are what truly stand out.”

### Social and Economic Considerations

The owner wanted to create this facility as much for the public as for him. He wanted to allow others to experience the mind- and future-expanding properties of music that had affected him so dramatically as a youth. As such, the “owner's expectations” very much included a number of social and economic considerations. The new structural system developed was absolutely critical to the successful creation of EMP. Without this key component, it is unlikely the facility would have moved forward, and certainly not with its present configuration or impact. Some of the social and economic benefits include:



- Adding music to learning experience for schoolchildren nationwide
- A nonprofit organization, EMP is developing curriculum for teachers in Seattle and nationwide. The purpose of the curriculum will be to expose children to music and the arts at a young age.
- Providing hands-on exposure to the latest in technology
- Interactive exhibits allow visitors to experiment with tools and techniques available to the general public only through the EMP experience.

### Exposing the Pacific Northwest to leading-edge architecture

Frank Gehry has an international reputation, drawing visitors from around the world to view his creations, such as the Guggenheim in Spain. EMP gives residents and visitors to the Pacific Northwest the unique opportunity of experiencing first-hand the work and artistry of this world-renown architect.

The “Seattle Center” was built for the 1962 World's Fair and has been used since then for a variety of cultural and entertainment purposes. The creation of EMP at the Center has revitalized the aging locale and provided the area with a new focus as the artistic center of the City.

EMP is expected to attract 800,000 visitors per year, with corresponding revenues to merchants and the city (from hotels, meals, shopping, etc.). The facility provides 620 jobs for local residents. The facility also generates

\$301,000 a year for the city of Seattle, paid for the next 40 years as a land lease.

Paul Allen set out to create a state-of-the-art facility that would provide inspiration, provoke thought, offer hands-on exposure to cutting-edge technologies and celebrate musical innovation.

*Jon D. Magnusson, P.E., S.E., is Chairman/CEO of Skilling Ward Magnusson Barkshire Inc. in Seattle, WA.*

#### OWNER:

Experience Music Project, Seattle, WA

#### STRUCTURAL ENGINEER:

Skilling Ward Magnusson Barkshire Inc., Seattle, WA

#### ARCHITECT:

Frank O. Gehry & Associates, Santa Monica, CA, in association with LMN Architects Seattle, WA

#### GENERAL CONTRACTOR:

Hoffman Construction, Seattle, WA

#### FABRICATOR:

Columbia Wire and Iron

#### ERECTOR:

Hoffman Construction, Seattle, WA

#### DETAILER:

Angle Detailing, Inc., Wilsonville, OR

#### SOFTWARE:

CATIA



# INTERNATIONAL TERMINAL BUILDING (ITB)

at San Francisco International Airport

**San Francisco, California**

*Peter L. Lee, S.E.*



## **Design Concept**

The new International Terminal Building (ITB) at San Francisco International Airport is the centerpiece of the airport's \$2.6 billion expansion and modernization program. Its comple-

tion greatly increases the efficiency and capacity of all international arrivals and departures with 26 new gates and maintains San Francisco's standing as America's gateway to the Pacific Rim. The roof structure and main façade of

the Terminal, visible from approaching roadways and the air, give the entire Airport a visual cohesiveness and an iconic sense of identity, both as a major public facility and as the city's front door to the world. The genesis of the



design is found in both the structural requirements generated by the site and the desire to create a symbolically appropriate form for the Airport. The form of the building reflects the need to span existing entry and exit roadways that run under the Terminal.

### Main Terminal & Departures Hall

The main roof structure consists of two sets of balanced cantilever trusses supporting a central third set of trusses linked together creating a continuous wing-like form. The system of trusses up to 29' deep spans 380' at its center and 160' at each end cantilever with an overall length of 860'. The Main Terminal's glass-enclosed "great hall," 705' long, 210' wide and up to 83' high, creates a dramatic departure point for travelers, but does so with an economy of form and material. The exposed steel

trusses utilize state-of-the-art steel tubular T-Y-K joint detailing and fabrication techniques of trusses sitting on spherical ball-joints atop 20 cantilevered concrete filled steel box columns, while the center spans are interconnected by "cast steel" pinned joint assemblies.

### Construction

At a total construction cost of \$840 million, the Main ITB consists of an integrated and innovative creative solution to complex project requirements and constraints. It was a significant accomplishment to keep these roadways operational during construction. Framed in structural steel, the structure includes 1.8 million sq. ft. of framed steel area (25,200 tons), 172,000 sq. ft. of exposed trussed steel roof (4,040 tons including main roof cantilevered box columns) and 760 tons of exposed steel

at Main ITB departure's level window walls and entrance canopy. Roof trusses were fully assembled in the shop and then disassembled into some 35 major pieces to minimize field connections and shipped directly to the site on barges. Once completed, trusses were jacked into position and the pinned in place.

### Seismic Performance

The airport's seismic performance goal of continued operation following a major earthquake is achieved for the Main ITB using a strategy of seismic isolation. The isolation system utilizes 267 friction-pendulum "cast steel" base isolators installed at the foot of each structural column, which allow up to 20" lateral displacement. The building's superstructure is separated from its foundation by a mechanism that allows the ground to move relative to the building. The design allows the weight of the building itself to provide inertia and damping, so that the seismic energy is dissipated rather than absorbed by the structure. The system reduces earthquake force demands on the building by 70%. With more than 1.2 million sq. ft. of floor space and more than 22 million cubic feet of interior volume, the terminal is the largest base-isolated building in the world.

### Analysis & Design

The project was analyzed, designed and detailed as an "essential facility" using site-specific response spectra generated for the soft Bay-mud soil site. The steel frame superstructure and main roof were designed to remain essentially elastic under the design basis earthquake with minimum ductility demands under the upper bound 1,000-year earthquake. The irregularities in plan and elevation for the new international terminal structure imposed great challenges for analysis and design. The arrival and departure levels constitute a huge platform for the superstructure, where twenty cantilever box columns support five main roof trusses above the departure level along with a three-story office block that is completely independent of the





main roof. Analysis and design was performed to study the interactions among the three structural components and the behavior of the base isolation system.

*Peter L. Lee, S.E., is an associate structural engineer with Skidmore, Owings & Merrill LLP in San Francisco.*

**OWNER:**

Airports Commission City & County of San Francisco  
San Francisco International Airport  
San Francisco, CA

**STRUCTURAL ENGINEER**

**OF RECORD:**

Skidmore, Owings & Merrill LLP  
San Francisco, CA

**STRUCTURAL CONSULTING ENGINEERS:**

OLMM Consulting Engineers  
Oakland, CA

Faye Bernstein & Associates  
San Francisco, CA

**ARCHITECT:**

Skidmore, Owings & Merrill LLP (SOM),  
Michael Willis Architects (MWA),  
Del Campo & Maru (DCM),  
Joint Venture Architects (JVA)  
San Francisco, CA

**GENERAL CONTRACTOR:**

Tudor Saliba, Petrini Corp and  
Buckley & Company (JV)  
Sylmar, CA

**FABRICATORS:**

The Herrick Corporation (AISC member)  
Pleasanton, CA  
South Shoulder, 2/3 of  
isolated area & roof infill  
PDM Strocal (AISC member)  
Stockton, CA  
North Shoulder and 1/2  
of isolated area

Nesco-XKT  
Mare Island, CA  
Roof Trusses

Canron  
Vancouver, Canada  
Curtainwall

**ERECTORS:**

The Herrick Corporation (AISC member)  
Pleasanton, CA  
South Shoulder & Isolated Area  
PDM Strocal (AISC & NEA member)  
Stockton, CA  
North Shoulder

**DETAILERS:**

Cal-West (NISD member)  
Pleasanton, CA  
South Milestone 1

Baseline (NISD member)  
Toronto, Canada  
South Milestone 2

Candraft (NISD member)  
Vancouver, Canada  
North Milestone 1 & 2

Hargrave (NISD member)  
Dallas, TX  
Areas 8 & 10

Lannon & Associates  
Grapevine, TX  
Area 9

NC Engineering (NISD member)  
Vancouver, Canada  
Roof & Curtainwall

**SOFTWARE:**

SAP90, ETABS (v6.0),  
and 3DBASIS-ME



# MCNAMARA

## Alumni Center

**Minneapolis, Minnesota**

*Jerod Hoffman, P.E.*

In 1957, the University of Minnesota Alumni Association first expressed a need for an alumni and visitor center for the campus. Throughout the next 43 years, this agenda item took on a life of its own. With the numerous University requirements and red tape, it was an uphill battle. The determination of three alumni and the generous donations of many other former students kept the momentum going for this very important building project. What started as a need for an alumni center grew into a multifunctional building that would serve the entire university. At 40,000 students, the University of Minnesota needed a focal point for prospective and current students, staff and alumni. With the selection of world-renowned architect Antoine Predock, the McNamara Alumni Center would become known not only for the importance of the people it serves but also as the monumental building on campus with a bold geometric form.

The 230,000 sq. ft. building consists of two portions; a seven-story rectan-



gular office block clad in copper and a 90' tall multi-surface "geode", which houses the public spaces. The Geode portion of the project is what makes this building unique. The Geode is a rock-like structure clad in granite, faceted and sliced with windows, or fissures, that crisscross in random patterns. Predock is known for his bold forms that resemble the landscape around them, as well as capturing the spirit and meaning of the building's use. He drew inspiration from the Split Rock geologic form on the North Shore of Minnesota. Also, the light that streams out the many irregular win-

dows at night resembles a beacon drawing people to this campus focal point. The inside of the Geode includes Memorial Hall, which is a 90' tall open atrium, Heritage Gallery and the reconstructed Memorial Arch.

### **Entrant's Role in the Project**

Meyer, Borgman and Johnson (MBJ) was the structural engineer of record for this project, responsible for all structural related design, analysis and document preparation from the foundation to the roof. MBJ's scope included the rectangular office portion, the Geode and the primary support

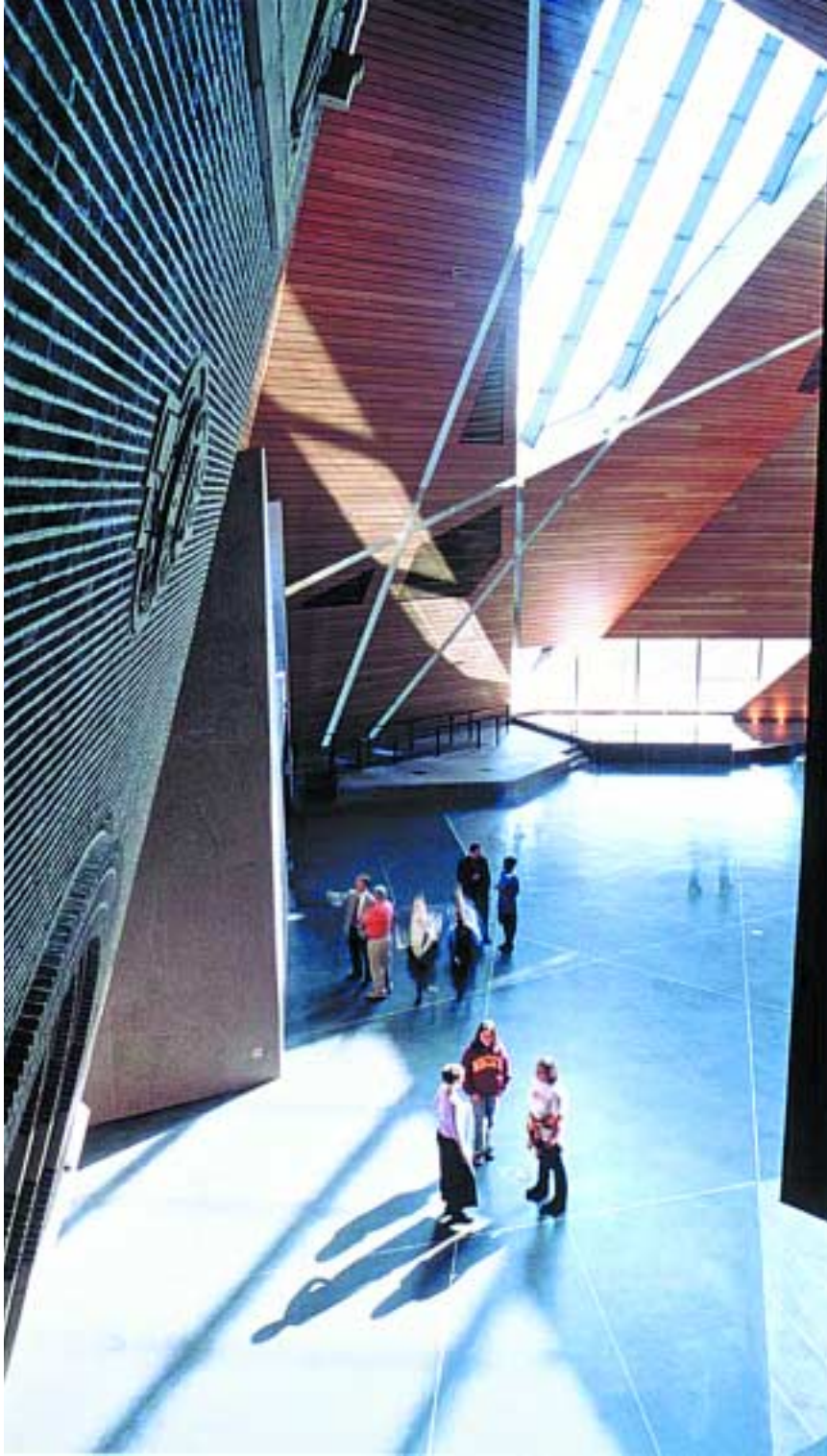

structure for the Memorial Arch. The office portion utilized cast-in-place post-tensioned concrete framing. The Geode portion included primary structural steel framing and a secondary steel framing system for supporting the granite.

MBJ provided essential coordination services throughout the design phase of the project, especially for the intricate relationships between the granite, windows, structural steel and roofing materials for the Geode. In ad-

dition, MBJ was responsible for construction phase services, including shop drawing review, construction coordination meetings and site inspections.

### **Original or Innovative Engineering Techniques**

Several areas of this project required original and innovative work by MBJ. The complex geometry of the Geode posed a difficult problem for modeling and analyzing the structural steel

frame that would create the exterior envelope of the building. There were 17 different surfaces, all sloping at various angles. It was immediately evident that the project would require a sophisticated computer model to set-up, manipulate and analyze the work points of the steel-framing members. MBJ's innovative approach to this challenge started by using AutoCAD to convert the architect's top of granite surfaces to top of steel surfaces, typically a 1'-4" offset. Work points were created and the steel beams were laid out on each surface, identified by line segments. Each surface had its own CADD drawing that referenced the same base model, which greatly facilitated updating framing layouts and preparing the construction documents. Once complete, this 3D-wire frame model was imported into a structural analysis computer program. This process eliminated the traditional step of hand input of dimensional coordinates for each beam of the structure, which was not feasible for the Geode. In addition, the top of steel CADD model was shared with the steel detailer for infinite precision in work points.

A second innovative approach by MBJ involved the development of steel connections. Again, the complexity of the framing required a different approach compared to typical steel-framed buildings. The following process was used to transfer the connection data and optimize the connection design:

MBJ detailed general connection relationships for all conditions. Many of the steel member sizes and shapes designed by MBJ were chosen based on the connection geometry;

Load data at the connections for each steel beam was extracted from the structural design program, organized in spreadsheet format and included as part of the structural documents. Many load combinations were studied to determine the most critical conditions. This load data had up to six times the amount of information that is typically provided to the steel fabricator;

Connection optimization and economy was achieved by collaborating

with the steel fabricator, and reviewing, editing and approving their connection geometry and recommendations.

MBJ also developed a unique secondary steel structure that provided support for the granite façade of the Geode. This thermally exposed system had to accommodate the cyclic expansion and contraction of the steel. The solution consisted of galvanized 4" x 4" steel tubes, spaced at 5' on center, and galvanized steel stub columns connected to the primary steel structure (see Figure 2). This system was detailed so that the bolted connections allow infinite movement cycles without damaging the steel, granite or any surrounding materials. The coefficients of friction and magnitudes of loads from these temperature movements were determined, and then maximum bolt tightening values were specified.

The unique geometry and load paths of the Geode placed unusual demands on the adjacent concrete framed office building. A lateral force applied to the seventh floor of the building from the Geode had a magnitude of 280,000 lbs., due to the self-weight and applied snow load on the Geode. Compared to the wind load on the building in this direction, this force is equivalent to adding six stories to the building, which greatly increases the requirements for the lateral load resisting system. MBJ utilized massive concrete shear walls, unique post-tensioned outrigger beams and driven steel pipe piles to bedrock to resist these forces.

The phased loading during construction required separate analysis from the completed structure. MBJ realized that if temporary slide-bearing connections were used in a few key areas during construction that the amount of force transferred at these areas could be substantially reduced. This innovative approach was cost effective.

### Technical Value to the Engineering Profession

This structure provides at least four areas of technical value to the engineering profession. First, it provides an example of how connection design may

be effectively developed and optimized for the most complex and irregular steel framed structures. The expanded breadth of information sharing and collaboration with the steel fabricator produces more appropriate and cost-effective solutions for these conditions.

Second, MBJ's efforts provide a solution for supporting thin granite veneer on sloped steel framed structures with large surface areas, complex geometry and/or random window openings. The solution exhibits several qualities, including the flexibility to be applied to many geometric conditions, ease of erection including allowance for construction tolerances and adequate space for insulation and waterproofing. Also, it accommodates critical thermal movements.

Third, this building models the potential for integrating concrete and steel framing systems for efficient cost-effective design solutions. Each system was chosen to best accommodate the framing requirements imposed.

Fourth, this project provides insight into the use of temporary slide-bearing connections during the construction phase to reduce load requirements.

### Social and Economic Considerations

The public's appreciation of this structural challenge makes it an important landmark for those on campus and also a draw to perspective students. During the design phase, the building was known as the Gateway Center, located at the edge of campus and symbolized by the original Memorial Stadium Processional Arch. The arch

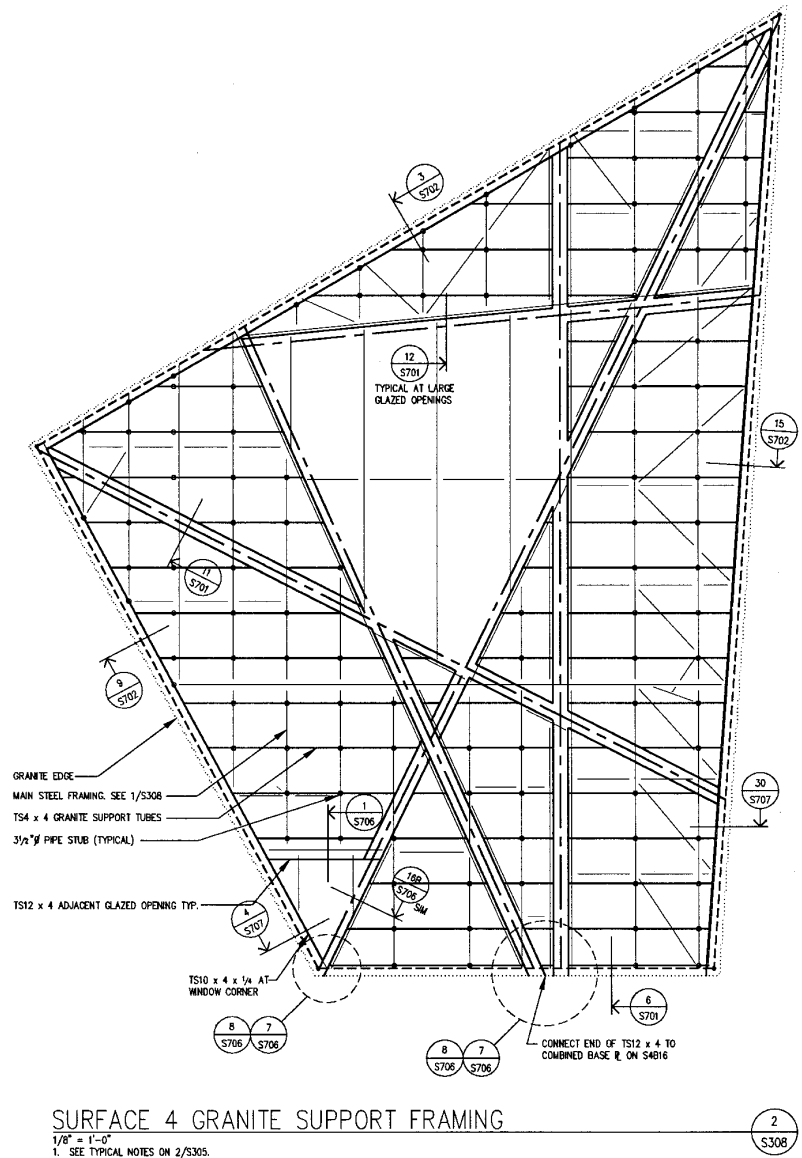

SURFACE 4 GRANITE SUPPORT FRAMING

was reconstructed within the new Memorial Hall (leaning inward at 15 degrees). The original brick and stone were salvaged from the recently demolished Memorial Football Stadium and rebuilt to create this 30' x 50', 70-ton arch. Once you walk through the arch, you enter Heritage Gallery, which preserves and displays artifacts and innovations of the University of Minnesota's 150-year tradition. Heritage Gallery and the rebuilding of Memorial Arch provide alumni and society with many social benefits. World War I veterans are honored with the inscription on the arch, and the memories of football players and fans are brought to life.

One direct social and economic benefit of the 90' tall Memorial Hall is that it provides a spectacular place to hold important public and University of Minnesota events such as speaking engagements, homecoming events and graduation and award ceremonies. The building structure is central to the grand appeal of this public space, and its position as the "gateway" to the University of Minnesota campus. Now in use, the public spaces of this building are booked with an average of 15 events every week.

This bold and controversial architecture provides for several economic benefits to the campus. It helps attract highly qualified students and professors, which raises the standard and reputation of the University. This unique building appeals to groups for highly publicized events and gatherings, and it symbolizes the forward, contemporary risk-taking thinking of University leadership.

## Complexity

Complexity is the single greatest theme illustrated by this project. In addition to the 3D, rock-like formation, the structural steel had to conform geometrically to other architectural constraints. The skewed, non-orthogonal layout of slit and large windows greatly increased the complexity of steel framing. No primary steel greater than 36" deep was allowed, which was a challenge with surface spans up to 100'. Almost all other buildings with large sloped surfaces have floors and

columns to back-up the surface, which makes the framing routine. This project was lacking those elements, making these spans and geometry extremely difficult to structure.

The project requirements for design and construction timetable were extremely aggressive for a building of this size and complexity. Multiple bid packages were utilized to provide for the fast-track schedule. Coordination with the team consultants and contractors occurred on a weekly basis, where MBJ lead many of the coordination issues for the Geode. Special care for designing and detailing steel framing for constructibility and tolerances was vital to efficiency. Strategies included oversize holes with special tightening requirements, bolted connections whenever practical and minimizing the amount of welding.

Many of the analysis, design and detailing aspects for this project can easily be considered out-of-the-ordinary, including:

**Complex 3D Computer model:** The large geometric model, which included approximately 1,000 joints and 1,700 beam segments, was unique due to its lack of redundancy and extent of the sloping and skewed members. The complexity of this model certainly outshadows that of either a large sports arena or high-rise building, which often have a lot of redundancy and limited skewed framing. The time required to completely create, refine and analyze the Geode frame was approximately 800 hours (4 to 5 months). This is magnitudes beyond what is typically spent modeling framing systems for mid-rise buildings.

**Structural analysis:** The overall system load path was very complex and impossible to determine without a robust 3D digital model. The system wind loads were evaluated in six directions, due to the irregular building shape. Typical member deflection limits did not apply. New deflection limits needed to be established (limited to two to four times less than typical structures) based on the granite system flexibility and sequential granite placement. In-plane steel bracing elements

were strategically placed to ensure stability and overall frame rigidity.

**Unique support requirements:** The structural supports at the top and the bottom of the Geode steel frame required design for unusually high permanent lateral loads, due to the sloped geometry and space frame nature of the framing. The foundation support system utilized special base plates with thrust bars, torsion resistant grade beams and battered steel piling. The lateral loads at the top of the steel frame were resisted by large embedded steel plates (up to 2' x 4' in size) cast into concrete beams, and ultimately transferred to concrete shear walls through the slab diaphragm.

**Connection design:** The severe geometry conditions resulted in several locations with up to eight steel beams framing to a common connection. Over 100 connection types were required. Typical buildings will generally have just five to 10 different steel connection types.

**Sequential deflection analysis:** For each surface the deflection patterns for four load components were studied, including initial steel framing, granite application, interior ceiling framing and applied live loads (snow, wind, and ice). These analyses were used to determine beam cambers and planning of granite erection. This was essential information to assist the contractor in providing the scheduled surface flatness.

## Meeting and Exceeding Owner and Client Needs

MBJ engaged the owner in the early phases of the project by reviewing the options for structural systems for the Geode, including concrete shell, built-up, prefabricated steel trusses and conventional steel framing. The owner's representatives and their consulting and contracting team members were a part of intense weekly coordination meetings throughout the design period. This was a unique collaborative and team-building effort. MBJ regularly led the discussions and maintained detailed meeting minutes for this process.

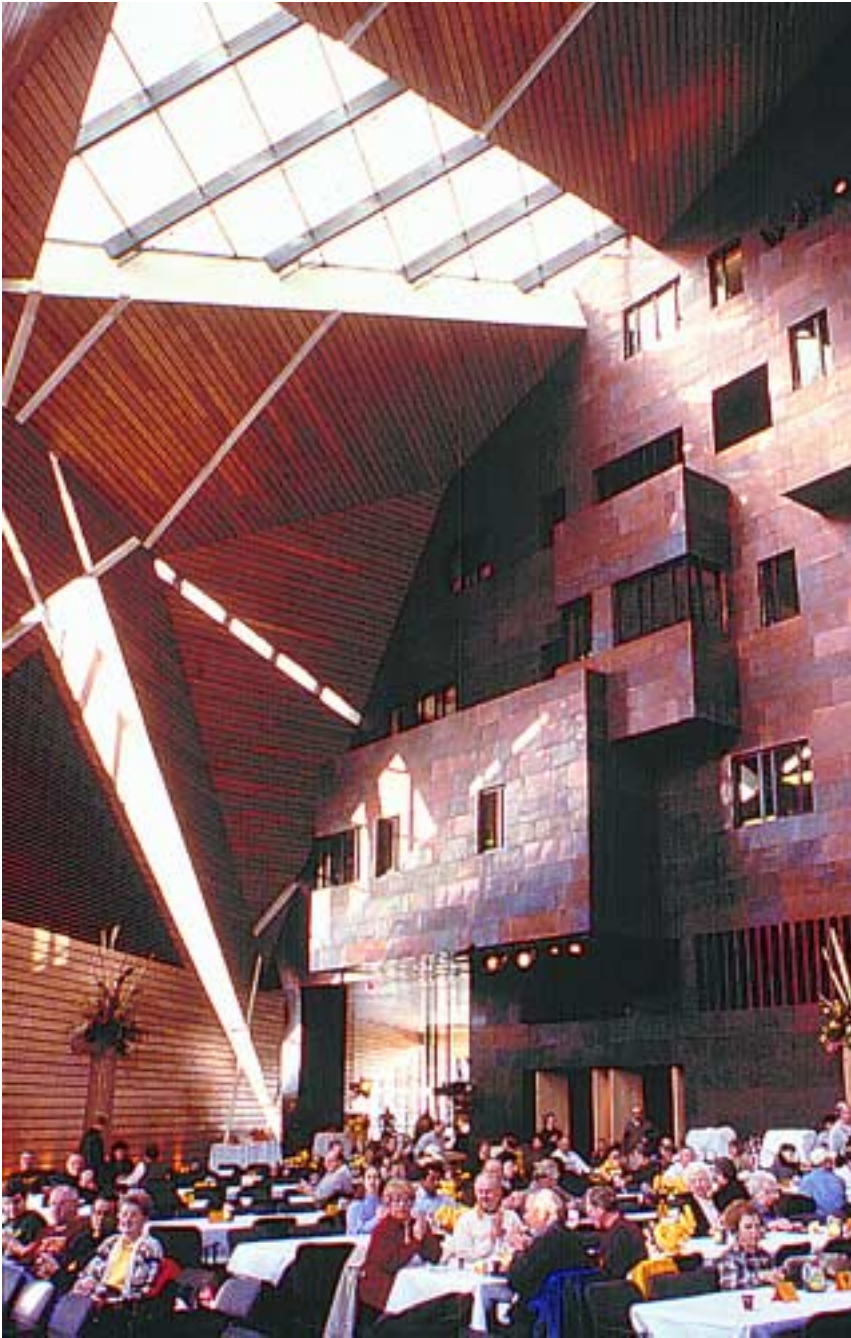

Cost-effectiveness was achieved by choosing the appropriate framing system, working closely with the steel fabricators and using readily available steel framing members. MBJ played an important role in meeting the construction schedule on this structurally challenging building. A phased, multiple bid package, construction document delivery system was used to fast track the construction of portions of the building while others were still being designed. This unique negotiated con-

struction process demonstrates how complex buildings can be built with aggressive schedules to meet the goals of the owner.

The final construction cost was slightly under the original budget estimate. This is remarkable for a building with great complexity and an expeditious construction schedule.

MBJ achieved success by meeting the goals and original concept of the owner. The success of this building relied heavily on the realization of the

Geode's unusual and sophisticated structure. Referring to the goals and aspirations of this building endeavor, Margaret S. Carlson, current executive director of the University of Minnesota Alumni Association said, "What I truly believe about higher education is that people come here filled with potential and desire and that universities change lives. And then they go on to change the world. So if we could build a monument to that transformation of lives and then changing the world, it would be a great thing." Once the building was completed she added, "This building is a testimony to courage and determination and the power of collaboration among those who shared a seemingly impossible dream."

*Jerod Hoffman, P.E. is Project Structural Engineer with Meyer, Borgman and Johnson, Inc. in Minneapolis.*

**PROJECT OWNER:**

University Gateway Corporation (consisting of: University of Minnesota Alumni Association, Minnesota Medical Foundation, and The University of Minnesota Foundation), Minneapolis, MN

**STRUCTURAL ENGINEER:**

Meyer, Borgman and Johnson, Inc., Minneapolis, MN

**DESIGN ARCHITECT:**

Antoine Predock, Albuquerque, NM

**EXECUTIVE ARCHITECT:**

KKE Architects, Minneapolis, MN

**GENERAL CONTRACTOR:**

Mortenson, Minneapolis, MN

**FABRICATOR:**

LeJeune Steel Company, Minneapolis, MN (AISC member)

**ERECTOR:**

Amerect, Inc., Newport, MN

**DETAILER:**

NC Engineering Company, Burnaby, British Columbia, Canada

**SOFTWARE:**

AutoCAD



# GATEWAY VILLAGE

Charlotte, North Carolina

*Clinton O. Rex, Ph.D., P.E.*



**G**ateway Village is one of the largest commercial building projects ever undertaken in Charlotte, NC. At the start of the project, it was also the largest private, mixed-use urban project in active development in the United States. The total project will be built on a 15-acre site in the heart of uptown Char-

lotte. It will include over 1,350,000 sq. ft. of office space, 5,000 parking spaces, over 500 residential units, street level retail space and an extensive garden common area.

An E-builder web site (author asked about name of web site) was established for the project so that information could constantly be available on the progress of the project.

Phase I—Block 800 of Gateway Village began construction in January 1999. The first occupants moved into the building in June 2000. Building 800, the first of two office buildings in this phase, contains 650,000 sq. ft. and is composed of two buildings connected by a three-story sky-bridge. The building encompasses two major public spaces, the Gardens at Gateway



and a five-story Promenade directly below the sky-bridge. The north and the south buildings sit on a one-story basement. Each building has typical floor plates of approximately 40,000 sq. ft. allowing flexible space layout and accommodating technology infrastructure.

The design floor loading was significantly higher than standard office

loading. First, all the floors have raised flooring to allow for the special wiring that would be required for the bank. Second, floor live load requirements far exceeded the typical 50 psf. Live load requirements ranged from a minimum of 100 psf to a maximum of 200 psf.

Foundations for Building 800 were a combination of spread footings at the basement floor level and pile caps on

driven steel piles at the first floor level. The basement and lobby level was constructed using reinforced concrete. Composite concrete encased steel columns were used at the interior column locations that extended to the basement floor. This allowed for a smooth transition from the concrete basement and lobby level framing to the steel framing above and it reduced



the size of the concrete columns in the basement space.

Two different lateral load-resisting systems were used in Building 800. In the north-south direction, each building has four eccentric braced frames incorporated into the building core. The east-west direction of each building features a partially restrained (PR) moment frame. Each main line of beams and columns in the building was used as part of the frame. Combinations of bare steel PR connections and composite PR connections were used. The bare steel connections were used at spandrel locations and interior columns adjacent to major floor openings. These connections used double angle web connections in combination with top and bottom clip angles to develop the connection moment resistance. The composite connections used double angle web connections in combination with a bottom clip angle and a reinforced composite slab at the beam top to develop moment resistance. Shear studs were used to transfer the forces out of the slab and into the beam at the connection.

Two additional challenges in the building included a very complicated façade and two building setbacks. First, the combined brick and curtain wall system was very complicated with five different planes of the face of brick jutting in and out from the building. Second, each end of the building and the roadside face of each building steps back at the sixth and seventh floors, resulting in all but a few of the exterior columns being transfer columns at these levels. The heavy roof required heavy steel transfer girders to accommodate setbacks.

The three-story sky-bridge connecting north and south parts of the building spans 80' resulting in nearly 18,000 sq. ft. of column free space on the fifth and sixth floors. The south side of the sky-bridge is directly attached to the south building while the north side of the bridge is separated from the north building with an expansion joint. A combination of long-span composite beams and king-post trusses were used to frame the fifth floor of the bridge. The king-post trusses were constructed

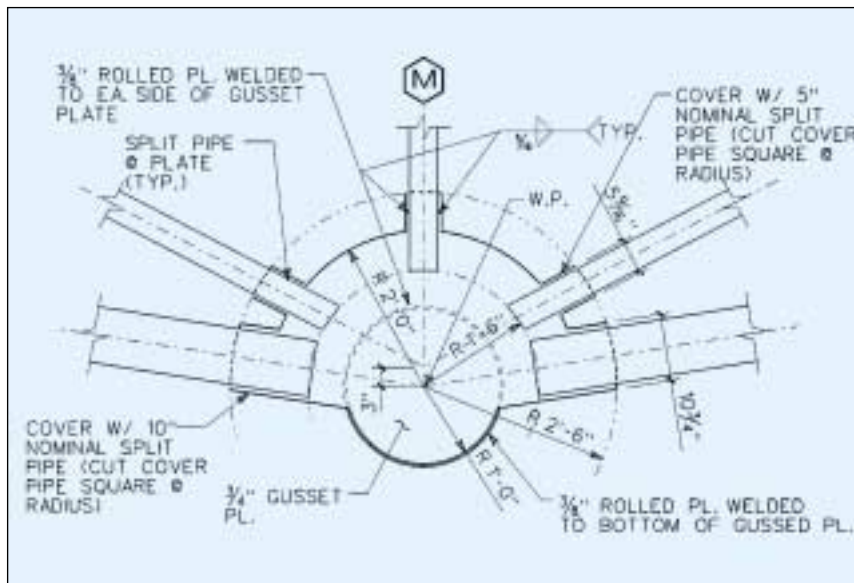

from round and rectangular HSS members in combination with traditional wide flange members and built-up steel shapes. The sixth floor of the sky-bridge is a two-story space. The floor is constructed using long-span composite joists provided by Vulcraft. Finally the roof is constructed of steel trusses made up from round and rectangular HSS sections. Both the floor and roof trusses were fabricated in the shop and shipped to the site. Special transportation permits were required, and they had to be brought to the site in the very early hours of the morning.

In summary, Building 800 met the owners' needs for large floor plates and technology infrastructure support. In addition, innovative steel technology, such as partially restrained moment frames, long-span composite joists and eccentric braced frames, were used to provide a cost effective structure which met the owners needs.

*Clinton O. Rex, Ph.D., P.E., is a design engineer with Stanley D. Lindsey and Associates, Ltd. in Atlanta.*

**PROJECT OWNERS:**  
Bank of America, Charlotte, NC

**STRUCTURAL ENGINEER:**  
Stanley D. Lindsey and Associates, Ltd., Atlanta, GA

**DESIGN ARCHITECT:**  
Duda/Paine, Durham, NC

**ARCHITECT OF RECORD:**  
Little & Associates Architects, Charlotte, NC

**GENERAL CONTRACTORS:**  
Rogers Hardin, Charlotte, NC  
Cousins Real Estate Corporation, Charlotte, NC

**FABRICATOR:**  
SteelFab, Charlotte, NC (AISC member)

**ERECTOR:**  
Buckner Steel, Charlotte, NC (SEAA member)

**DETAILER:**  
Steel Detail, Charlotte, NC

**SOFTWARE:**  
RAM S-Beam and SANDE (an in-house analysis and design program)



# PDX

## Roadway Canopy and Pedestrian Bridges

---

**Portland, Oregon**

*Keith Robinson, P.E., S.E.*





facilities and finally the Canopy and Pedestrian Bridges, which tie all the other program elements together.

With parallel runways at each end of the terminal, there was no opportunity to extend the parking, road system and curb space linearly as is typically done at most airport expansions. The only economical option was to expand the parking vertically and create a series of adjacent parallel road systems on two levels. The Canopy and Pedestrian Bridges were in many ways the keystone of the overall program, which allows each of the other elements to function effectively.

The Canopy protects all of the road systems (drop-off, pick-up, parking shuttles, taxis, buses and commercial vehicles) as well as the Pedestrian Bridges from Portland's persistent rainy weather. With complete coverage by the Canopy, all of the roadway lanes can be used for pick-up or drop-off at peak times. The Pedestrian Bridges improve the roadway capacity in multiple ways. By creating direct protected access from the parking structure to the ticket lobby, many passengers now choose to park rather than use the terminal roadway at all. In addition, passengers no longer cross through vehicular traffic, which enables the

**T**he PDX Roadway Canopy and Pedestrian Bridges provided the final touch on an ambitious \$150 million construction program to improve public access to the Portland International Airport. At less than 12 miles from the city center, the airport literally serves as the front door to the Rose City for over 14 million passengers annually. Today, the Canopy forms the ceiling of a grand new entry to the city of Portland.

Since construction of its first parking garage in 1988, the airport has experienced unprecedented growth with rates approaching 15% annually. This increase in use overwhelmed the existing infrastructure that serves the terminal, causing frequent backups on the roadway and closures to the parking garage. The Port of Portland in re-



sponse to this phenomenal growth launched the Terminal Access Program (TAP) in 1994. The program consisted of several projects, including roadway widening, roadway realignments, terminal expansion, garage expansion, expansion of curb-side drop-off and pick-up zones, expansion of rental car

roadway to operate more efficiently. The suspended Pedestrian Bridges also free the roadways of obstructing columns.

The Canopy extends from the west elevation of the garage to the east elevation of the terminal, covering a total area of approximately 120,000 sq. ft.

Ten triangular steel trusses, each 15' deep and 12.5' wide, span 180' between columns at the garage and terminal structures. Trusses are spaced 55' on center along the length of the roadway providing weather protection along more than 500' of roadway. Each Canopy truss is constructed from three 16" diameter parallel pipe chords bent in an arch shape. Truss web members, including verticals, diagonals and horizontals are constructed from 5", 6" and 8" diameter pipes connecting at the chords with traditional, mitered, pipe-to-pipe T, K and Y joints. Specially designed open-web joists with WT chords and double-angle web members span 42.5' between the triangular trusses as in-fill framing to support the glass skylight covering. Steel details were specifically tailored to support and minimize the cost of the skylight system, which includes over 2,800 individual panes of glass.

A pair of steel framed pedestrian bridges suspended from the Canopy trusses provides access between the terminal and parking garage for passengers. The Pedestrian Bridges span the expanded roadway from the fourth level of the garage to new vertical circulation cores at the terminal. Because vertical circulation cores at the garage and terminal do not align, the Pedestrian Bridges are constructed in an 'S' curve to deliver pedestrians from core to core. Bridges are framed with conventional slabs on metal decks spanning between composite, wide-flange joists supported by 3' deep 'S' curved plate girders. The plate girders are suspended from the Canopy trusses with pairs of 1 3/8" diameter, 150 KSI, Dywidag threaded steel tension bars in a splayed fan configuration located at strategic points along the length of the bridge.

Design loads for the Canopy and Pedestrian Bridges were based on Uniform Building Code (UBC) criteria. Because of the unique air-foil shape of the Canopy, wind tunnel studies were conducted to determine extreme wind loading conditions. Results of those studies indicated peak wind pressures well in excess of basic UBC require-

ments with wind loads as high as 80 psf at the leading and trailing edges of the structure. Other design considerations included Canopy snow loads, pedestrian live loads, thermal expansion and contraction loads and seismic loads. Because Portland is located in UBC Seismic Zone 3, site-specific investigations were conducted to determine appropriate seismic ground motions. Dynamic response spectrum analyses of the independent terminal and garage structures as well as Canopy and Pedestrian Bridge structures were conducted to determine each element's response to specific ground motions. Analyses of the Canopy and Pedestrian Bridges utilized three-dimensional computer modeling, requiring as many as 18 loading combinations to insure all conceivable loading conditions were accounted for in design of the structures. Design of the steel elements was based on provisions of the AISC Manual of Steel Construction for Allowable Stress Design (ASD), the AISC Manual of Steel Construction for Load and Resistance Factor Design (LRFD), and AISC Seismic Provisions for Structural Steel Buildings. The AISC Hollow Structural Sections Connections Manual was used extensively for design of the Canopy truss connections.

Because the Canopy and Pedestrian Bridges span between two independent structures, the design and detailing needed to allow the terminal and garage structures to move independently in a seismic event. To allow independent movement between the structures, the Canopy and bridges are anchored to the garage and allowed to slide on teflon bearing pads at the terminal supports. These slip connections proved challenging when designing the Pedestrian Bridge suspension rods. Because the Canopy trusses form an arched shape with the terminal end free to move, the arch tends to flatten and slide towards the terminal as it is loaded. As the Canopy trusses deflect and slide, loads in the Pedestrian Bridge suspension rods vary greatly due to their splayed fan configuration. In extreme loading conditions, some suspension rods would become slack

and sag. To prevent this, pre-compressed coil springs were incorporated in the rod suspension system to maintain tension in the rods under all loading conditions.

Fabrication and erection of the Canopy and Pedestrian Bridges also proved challenging, since the airport, including roadway access, needed to remain operational during construction. A plan was developed with the Port and general contractor to temporarily relocate all public access to the lower roadway, leaving the upper roadway to serve as a protecting cover for the public below. Many other safety measures were included in the erection activities, such as debris netting, barricades and barriers and coordination with airport operation managers to insure public safety during critical activities. Fabrication of the Canopy trusses and Pedestrian Bridge steel was completed by an AISC Cbd Certified shop approximately 25 miles away from the airport and shipped to the site on flatbed trucks. Because each Canopy truss is 15' deep, 12.5' wide, and 220' long, it was necessary to ship each truss in four individual sections. Before shipping, each truss section was fit-up in the shop to insure proper fit-up in the field. With restricted erection space and crane size limited by loading capacity of the existing roadway structure, it was necessary to erect each truss segment individually, temporarily supported by specially designed mobile shoring towers. After field connections were made for each truss segment, the shoring towers were lowered and rolled down the roadway in a leap-frog manner for erection of each successive Canopy truss. Bridge erection directly followed truss erection, allowing initial installation of the suspension rods from the completed trusses above. Bridge framing was initially erected on temporary shoring platforms to limit Canopy and Pedestrian Bridge deflection during erection and placement of Canopy skylight elements. Once placement of the concrete bridge deck was complete and Canopy skylight elements were in place, suspension rods were tensioned to finally lift and level the Pedestrian

Bridges from their temporary shoring. Erection of over 800 tons of Canopy and Pedestrian Bridge steel was completed in less than four months under very restrictive conditions.

Completion of the PDX Canopy and Pedestrian Bridges culminated with re-opening of the upper roadway to public traffic on May 25, 2000. Thanks to the efforts of all involved, the project was completed under budget, ahead of schedule and without injury. As the final touch to the Port of Portland's Terminal Access Program, the PDX Canopy and Pedestrian Bridges not only provide a lasting first impression to Portland area visitors, but also serve as the keystone to the entire Terminal Access Program, allowing each element of the program to function most effectively.

*Keith Robinson, P.E., S.E. is an Associate with KPFF in Portland, OR. He was Project Manager on the PDX Canopy and Pedestrian Bridges project.*

**PROJECT OWNER:**

Port of Portland

**STRUCTURAL ENGINEER:**

KPFF Consulting Engineers,  
Portland, OR

**ARCHITECT:**

Zimmer Gunsul Frasca Partnership,  
Portland, OR

**GENERAL CONTRACTOR:**

Hoffman Construction Company,  
Portland, OR

**FABRICATOR:**

Fought and Company, Inc.,  
Tigard, OR (AISC member)

**ERECTOR:**

REFA Erection Inc., Tigard, OR

**DETAILER:**

Dowco Consultants, Ltd., Burnaby,  
B.C., Canada  
(AISC member, NISD member)

**SOFTWARE:**

SAP 2000n (non-linear version),  
RISA 3D, RAM S-Beam, MathCAD,  
Excel.





# INDOOR FOOTBALL PRACTICE FACILITY

at the University of Illinois—Urbana/Champaign

**Champaign-Urbana, Illinois**

*Roger H. Reckers S.E., and Brian M. Spencer*



The University of Illinois' Indoor Football Practice Facility is a building conceived not only from its internal function but also from an awareness of the adjacent

buildings and open space. The result is a building design that is unique in its form and yet contextually responsive with its scale and materiality.

The project site is located adjacent the Intramural Physical Education

Building (IMPE) and the historic Memorial Stadium. In considering the impact of the building on this location, it was determined that the building would be limited in area, as well as height. These parameters were estab-

lished in the interest of not impacting the historic stadium adversely. The height was limited such that the cornice of the new facility could not exceed the top of the fascia of the adjacent IMPE Building; the roof however could extend above this limit. It was determined that the building would be composed of an 80-yard football field and one end zone.

As the building mass for this type of facility is in large part a result of its roof forms and structural systems were investigated, beginning with conventional gable and arch roofs, then considering hip roof forms, both straight, sloped and curved, finally arriving at a hybrid form.

The hybrid form, the semi-parabolic dome, is composed of an arched form combined with a gable. Rather than spanning the field in the short dimension with a series of trusses, a large single-arched box truss spans the length of the field and supports 1/2 of the total roof load. The box truss assembly is composed of two identical trusses tied together with horizontal and diagonal bracing in the top and bottom chords. To help with fabrication, the chord members and the web members were composed of W14 rolled sections.

The arched box truss assembly is 10' deep by 30' wide and spans approximately 320'. It is supported on the north by two concrete buttresses and on the south by a two concrete buttresses that incorporates a stair tower

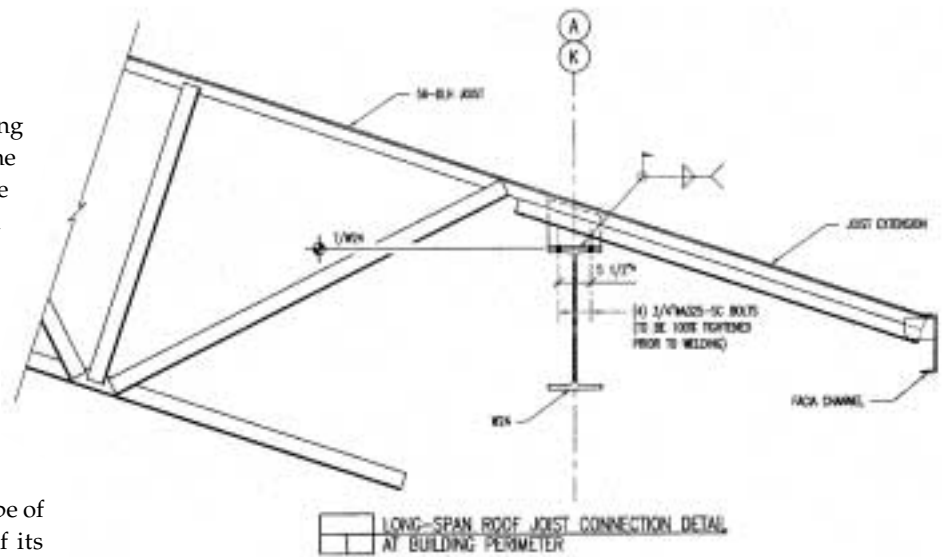

and two observation decks. The center truss is arranged asymmetrically so that its spring point is higher at the end zone and lower at the opposite end. Open web steel joists compose the balance of the roof structure spanning east west from the center long-span truss to steel girders at the perimeter of the building. These primary and secondary structural elements support 3" wide rib metal roof decking.

The gravity loads supported by the spandrel girders are transmitted to the perimeter columns spaced at 20' on center. These columns then transmit the gravity loads into the foundation and the wind loads into the foundation and roof diaphragm.

The foundation system for the facility utilizes reinforced cast-in-place concrete drilled piers 5' in diameter to about 25' in depth. A single drilled pier and pier cap is located beneath each column along the perimeter of the building. A grade beam spans between the drilled pier foundations and supports the masonry building enclosure above. At each reinforced concrete buttress, a group of three drilled piers are utilized to resist lateral movement (sliding) caused by the large thrust from the long-span arch.

The construction cost of the facility is \$ 12,000,000.

*Roger H. Reckers S.E., Principal, and Brian M. Spencer, Project Engineer, are both with Tylk Gustafson Reckers Wilson Andrews, LLC, in Chicago.*

**OWNER:**

Division of Intercollegiate Athletics, University of Illinois at Urbana - Champaign

**STRUCTURAL ENGINEER:**

Tylk Gustafson Reckers Wilson Andrews, LLC, Chicago, IL

**ARCHITECT OF RECORD:**

Isaksen Glerum, P.C., Urbana, IL  
Severns Reid and Associates, Champaign, IL

**DESIGN ARCHITECT:**

Ratio Architect, Inc., Indianapolis, IN

**GENERAL CONTRACTOR:**

Ore W. Vacketta & Sons, Danville, IL

**FABRICATOR:**

United Steel Fabricators, Inc., Indianapolis, IN (AISC member)

**ERECTOR:**

Crevac Inc., Danville, IL

**DETAILER:**

AED Inc., San Diego, CA

**SOFTWARE**

Eagle Point Frame Analysis and Design and RAM Analysis—RAM S-Beam





# EIFFEL TOWER II

Las Vegas, Nevada

*Farzad Naeim, Ph.D., S.E.*

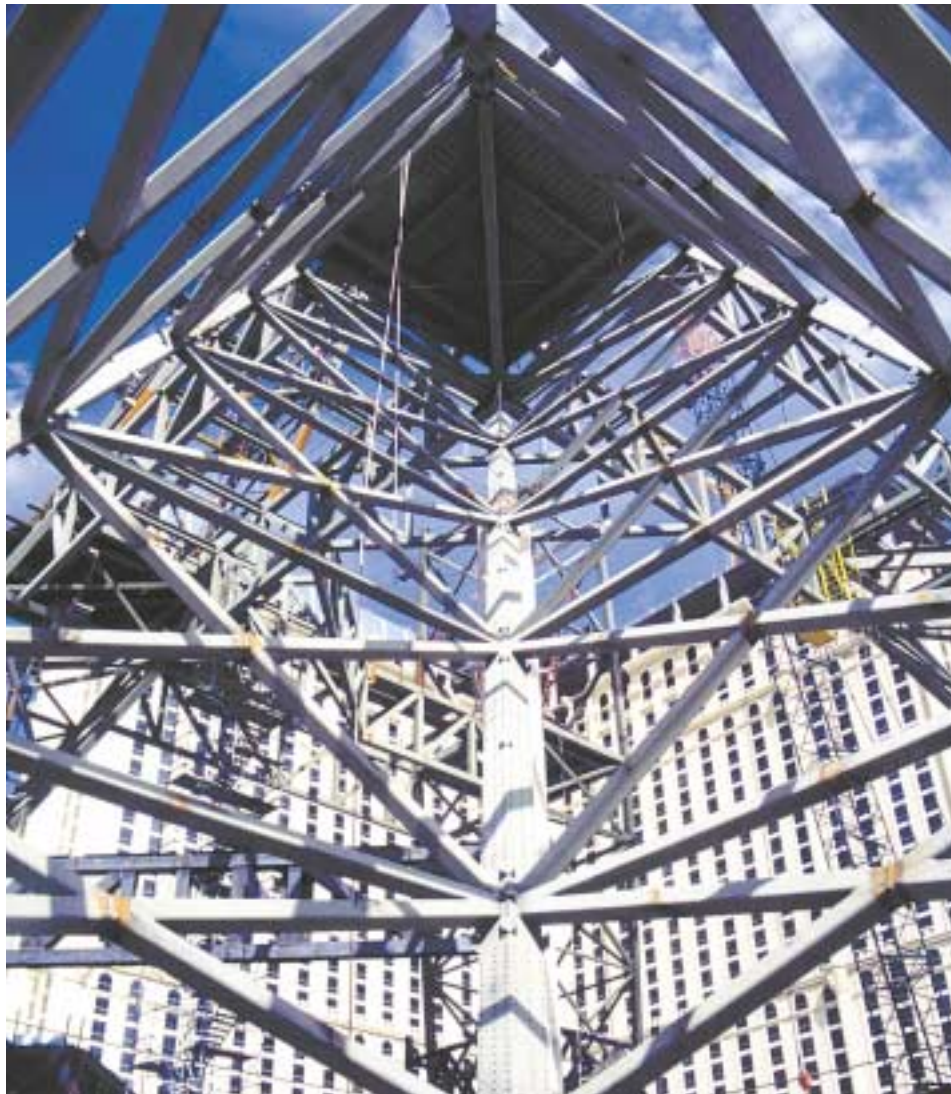



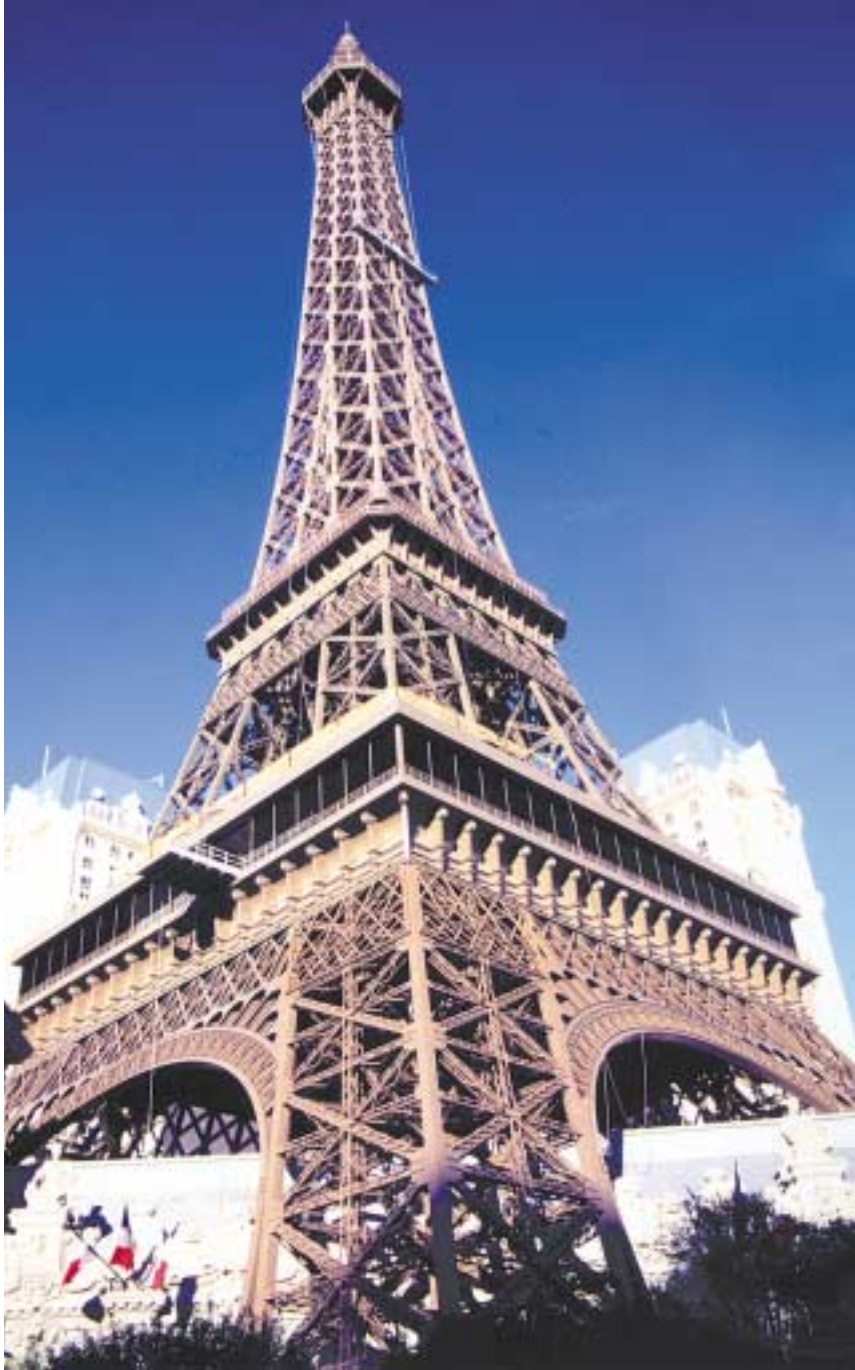

ties of arson and other terrorist activities.

### **Creative Structural Design**

In order to create this authentic replica of the 100-year-old Eiffel Tower icon, the design team had to develop innovative ways to create and meet today's standards, codes and life safety issues. While this tower looks like the original, the structural design is markedly different than the original tower. This is a welded structure, although approximately 300,000 fake rivets are used for aesthetic purposes. The lower one-third of the tower utilized tube sections camouflaged with non-structural laces to retain the original look of the Eiffel Tower. The elevators from the restaurant level to the top are entirely supported by complex planar trusses that form the restaurant's floor. Special laboratory tests and nonlinear analytical studies were needed to validate the lacing angles, as used in the upper portions of the original tower, since these angles violate the letter of current codes.

### **Automated Fabrication**

The tower chords and other main components were shop manufactured and prefabricated in Phoenix. Numerically controlled, AutoCAD-driven machines were used to automatically cut the plates to precise sizes. The chords were then knocked down and shipped

**A** 540', 50-story reincarnation of the Gustav Eiffel masterpiece now stands in front of the Paris Hotel/Casino in Las Vegas. This half-scale replica of Eiffel's masterpiece, while preserving the authentic beauty of the original tower, utilizes a modern structural system conforming to the complex requirements of the contemporary codes and performance requirements. The Eiffel Tower II design had to specifically deal with the extremely hostile weather conditions of a desert environment as well as safeguard against the possibili-



in pieces to the site in Las Vegas for assembly.

### Technical Innovations

Five main issues controlled the structural design of this project. Proper addressing of each of these issues required application of state-of-the-art technology as follows:

**Extreme Changes of Temperature:** 70°F day to night, 45° side to side (under the sun or in the shade). Extensive finite element analyses of thermal effects were necessary.

**Detailed Fire/Arson Scenarios:** 16 individual arson scenarios were investigated to optimize the performance and minimize the fireproofing requirements. Complex nonlinear buckling and thermal analyses were needed.

**Innovative Welding and Manufacturing Technologies:** Precision-welding technologies utilized in airplane and ship manufacturing were specified and executed.

**Plumbness of the Tower:** The tower as constructed could not be out of plumb by more than one inch along 540' of height in order for the elevators to be functional. Laser technology was used to monitor the tower's plumbness under construction.

**Wind Deformations and Vibration Control:** Extensive computer analyses were performed to control vibrations due to operation of elevators and achieve optimum resistance to 90 mph winds.

### Conclusion

Perhaps no other structure in the world represents the glory of sheer structural engineering know-how as the Eiffel Tower. In contrast with the prevailing architectural practice to hide the structure within the architecture, this tower standing in front of a most modern entertainment center is a vivid reminder of the achievements, complexity and vitality of the practice of structural engineering.

The structural design team faced many challenges in bringing the Eiffel Tower to the "Strip" in Las Vegas. The structural design used steel, in lieu of the originally proposed aluminum, in



order to limit the movement at the top of the tower in a wind, so that the patrons would not get sick. The engineers were also required to make the tower stable if the support of one of the legs was lost due to a fire. These are only two of the many design obstacles that were involved in bringing this monument to the desert.

*Farzad Naeim, Ph.D., S.E., is Director of Research & Development with John A. Martin & Associates, Inc., in Los Angeles.*

#### PROJECT OWNER:

Park Place Entertainment Corporation, Las Vegas, NV

#### STRUCTURAL ENGINEER:

John A. Martin & Associates, Inc., Los Angeles, CA

#### DESIGN ARCHITECT:

Bergman, Walls & Associates, Ltd., Las Vegas, NV

#### PRODUCTION ARCHITECT:

Leidenfrost / Horowitz Associates, Glendale, CA

#### GENERAL CONTRACTOR:

Perini Building Company, Phoenix, AR

#### FABRICATOR:

Schuff Steel Company, (AISC member) Phoenix, AR

#### ERECTOR:

Schuff Steel Company, (AISC member, NEA member) Phoenix, AR

#### DETAILER:

Schuff Steel Company, (AISC member) Phoenix, AR

#### SOFTWARE:

AutoCAD, SAP 2000, Robot

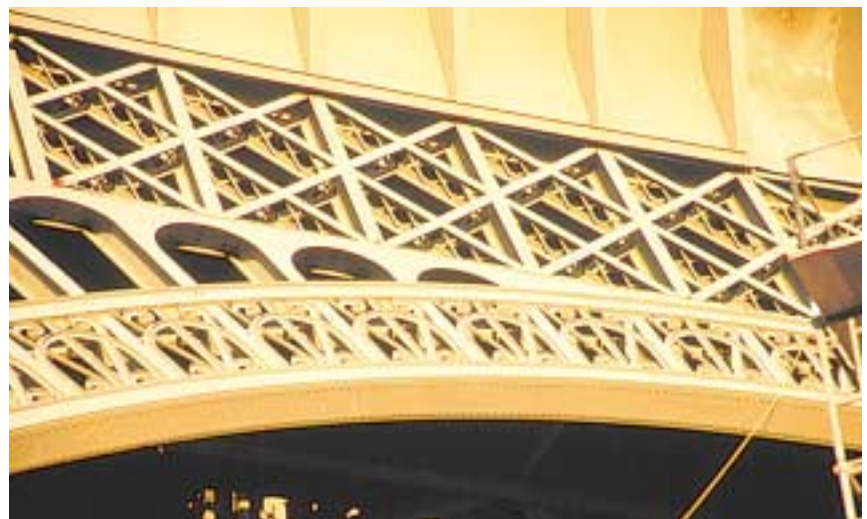



# ONEIDA

## Junior/Senior High School Additions

**Oneida, New York**

*Richard L. Applebaum, P.E.*

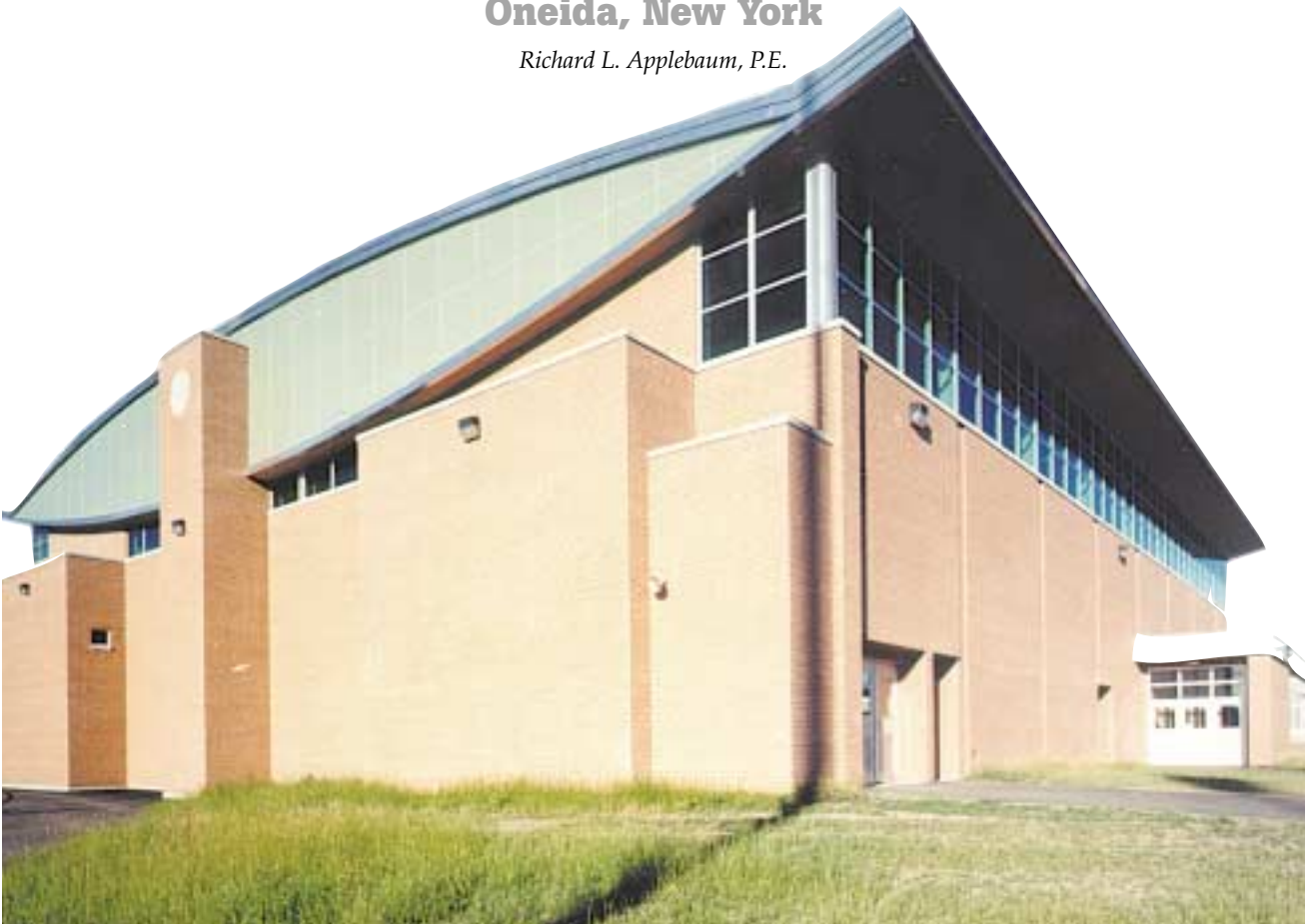

*(Top) Northwest corner of the gymnasium addition showing the expression of the truss on the exterior elevation. This photo also shows the clerestory windows that separate the roof structure as a whole from the masonry box that is the gym. At night with the lights on, the entire roof "floats" over the heavy brick base. (Right) Interior shot of the gym showing the clerestory window wrapping around the corners as well as the slot windows under the trusses on the west elevation. It enhances the light feeling of the roof structure, so it may be seen as an element unto itself - a sort of "wing" floating above the gym floor.*



*Side view close-up of double-bowed Oneida Junior/Senior High School gymnasium truss*

The Oneida High School gymnasium addition is an excellent example of how the use of structural steel, through the creativity and coordination of the design team, can create a dramatic visual impact.

The gym addition is approximately 122' by 149'. The roof structure consists of steel trusses spanning the 122' dimension, spaced approximately 17'-2" on center. Spanning between the trusses are 12" standard K-series joists. The unique aspect of the trusses is that the top chord bows up and the bottom chord bows down, meeting at a common working point at the exterior columns.

The roof structure in a gym is the dominant design element. After people enter a gym, their eyes rise up to take in its full size and are caught by the roof structure. Therefore, it was the de-

sign intent to make the roof structure a dominant element in the gym's design.

Visually, the architect was looking for a roof structural shape that would appear to be light and floating over the gym's basketball court while light poured into the gym from the long sidewalls. During the preliminary design phase, it was determined that the use of double-bowed trusses would achieve this goal. The use of conventional long span joists was considered but rejected because they did not create the desired visual effect. These structural elements are used in many gym roof structures and often appear heavy and over powering.

The curved bottom half of the roof structure brings the spectator's eye upward from the center of the gym to the exterior walls, which have an expanse of glass between the roof structure and the masonry walls below. Coupled

with the reflected curve in the truss top chord, this gives the structure an appearance of a wing suspended from the end walls of the gym. To complete the gym's design, the truss was accented by expressing its double-bowed shape on the exterior of the building.

The truss is very simple and elegant with very little load going to the web members. This allowed us to use 3" diameter standard pipe for the web, which provided a very light "feel" to the truss. The top and bottom chords consist of 8" wide flange sections. The roof trusses weigh approximately 90 lbs. per linear foot.

The owner was initially skeptical of the gym roof structure's cost. The engineers had to convince the school district that the cost of the double-bowed trusses with small purlins between the trusses would be no more expensive than conventional long span joists before they would accept the gym's design. The popularity of this truss has grown since this project, and we have received requests for this type of roof truss on three more school projects.

*Richard L. Applebaum, P.E., is President of Klepper, Hahn & Hyatt in Syracuse, NY.*



**OWNER:**

Oneida City School District

**STRUCTURAL ENGINEER:**

Klepper, Hahn & Hyatt, Syracuse, NY

**ARCHITECT:**

Bell and Spina Architects,  
Syracuse, NY

**GENERAL CONTRACTOR:**

B.F. Yenny Construction, Syracuse, NY

**FABRICATOR,**

**ERECTOR AND DETAILER:**

Raulli & Sons, Inc., Syracuse, NY  
(AISC member)

**SOFTWARE:**

RISA Frame and Truss Analysis



# WOODSTOCK

## Branch Library

**Portland, Oregon**

*Christopher L. Thompson, P.E., S.E.*

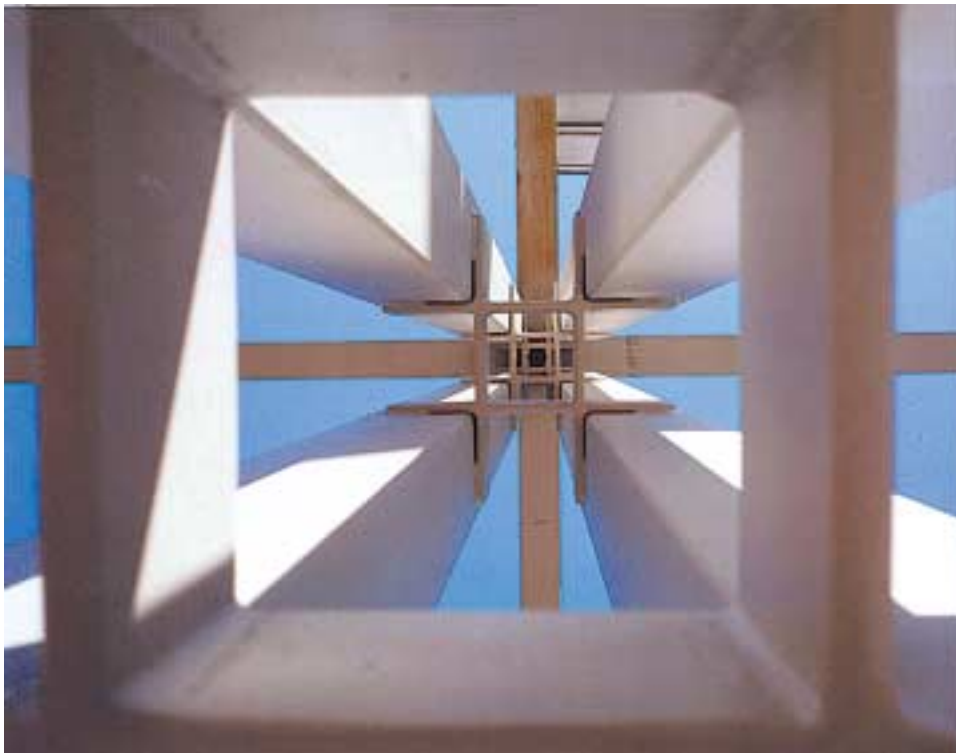

**T**he Multnomah County Library system has branch locations spread throughout the Portland, OR, area which lies at the heart of the county. In 1996, Multnomah County's electorate approved a \$30

million bond measure to modernize and/or replace the branch libraries. Headed by Thomas Hacker and Associates Architects, the multi-disciplined design team chosen for the project evaluated 12 libraries in all. Following the evaluations, eight

branch libraries were renovated and four new branch libraries were designed.

The Woodstock branch was the first branch to be replaced, and was intended to be the model project for all of the replacement branch libraries. It is



certainly a statement of the function and form of learning spaces by the architect. The openness of the structure was designed to reflect the openness of knowledge and information of the library, a concept founded by Benjamin Franklin with the idea that education and knowledge should be available to all. The design intent also called for the library to serve as a lantern for the

community: a building that would light the area and bring the community together.

The design concept called for high volume, open space in the reading room/stack area. The column layout was driven by book stack modules. The architect also desired to showcase the structure, exhibiting a simple system

that worked in harmony with the space.

Several options for structural systems were investigated, including structural steel, reinforced concrete and heavy timber. Hybrid systems, combinations of materials, were also considered. The design intent favored columns that were "transparent" to the space. Interruptions of the space with

vertical braced frames did not serve the vision or function for the building.

The innovative solution provided by Degenkolb Engineers was a system of cantilevered columns designed to resist lateral loads from wind and earthquakes. The use of cantilevered columns allowed for a space free of vertical bracing elements, such as braced frames. Special moment resisting frames were originally considered, but the transverse spans of 40' in the reading room rendered that solution ineffective.

The cantilever columns required innovative engineering, as the architect designed slender columns with minimum visual impact. Concrete columns were originally considered but were not chosen due to the required size for stiffness and strength. Steel wide flange columns were considered but were not chosen due to linear proportions and the desired visual effect.

The final column solution consisted of a "cruciform" column that was built from four 6x6 steel angles, laced intermittently. The spacing of the angles was varied from base to roof to provide an efficient distribution of stiffness and strength. The columns are rigidly connected to the roof girders to provide the required collector capacity and a degree of redundancy in the lateral force resisting system.

The lateral drift of the building was carefully considered in the design. The inherent flexibility of the cantilevered column system needed to be considered in connections of non-structural elements, such as the external glazing. Non-linear analysis procedures were used to more accurately estimate the actual drift of the building. Based on this analysis, and considerations of the non-structural elements, the drift of the building was limited to approximately 50% of the 1997 Uniform Building Code (governing code in Oregon) allowable.

*Christopher L. Thompson, P.E., S.E., is Principal and Group Manager at Degenkolb Engineers in Portland, OR. He also served as Project Manager on the library.*

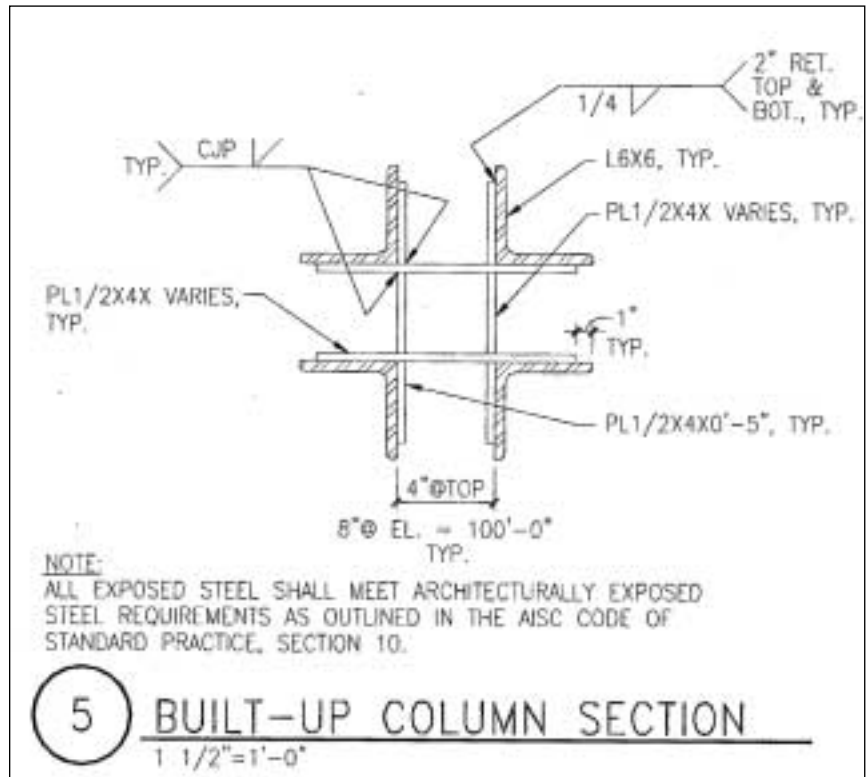

**OWNER:**

Multnomah County Libraries,  
Portland, OR

**STRUCTURAL ENGINEER:**

Degenkolb Engineers, Portland, OR

**ARCHITECT:**

Thomas Hacker and Associates  
Architects, Portland, OR

**GENERAL CONTRACTOR:**

McCarthy, Portland, OR

**FABRICATOR:**

CL Fab, Inc., Portland, OR

**ERECTOR:**

Volk Steel Erectors, Inc., Gresham, OR

**DETAILER:**

Certified Technical Consultant  
Services, Inc., Portland, OR