

..AISC E&R Library



5549



G. K. Rantala
1933

**STRUCTURAL
AND
SHIPBUILDING SHAPES**

**THE PHOENIX IRON COMPANY
PHILADELPHIA, PA.**

STRUCTURAL
AND
SHIPBUILDING SHAPES

Copyright, 1931
The Phoenix Iron Company

THE PHOENIX IRON COMPANY
PHILADELPHIA, PA.

THE PHOENIX IRON
COMPANY

1931

GENERAL OFFICES

PHILADELPHIA, PA.

DISTRICT OFFICES

ALBANY
BOSTON

NEW YORK
WASHINGTON

PLANT

PHOENIXVILLE, PA.

SECTIONS ROLLED

BEAMS

Standard—3", 4", 5", 6", 7", 8", 9", 10", 12", 15", 18", 20"

Phoenix—8", 10", 12", 15"

CHANNELS

Standard—3", 4", 5", 6", 7", 8", 9", 10", 12", 15"

Shipbuilding—6", 7", 8", 9", 10", 12", 13", 15"

ANGLES

Equal Legs—8" × 8", 6" × 6", 5" × 5", 4" × 4",

3½" × 3½", 3" × 3", 2½" × 2½", 2" × 2"

Unequal Legs—8" × 6", * 8" × 3½", * 7" × 5", * 7" × 3½",

6" × 4", 6" × 3½", 5" × 4", 5" × 3½",

5" × 3", * 4½" × 3", 4" × 3½", 4" × 3",

3½" × 3", 3½" × 2½", 3" × 2½", 3" × 2", 2½" × 2"

* Special.

BULB ANGLES

10" × 3½", 9" × 3½", 8" × 3½", 7" × 3½",

7" × 3", 6" × 3", 5" × 2½"

TEES

6" × 4½" and 6" × 5¼"

ZEES

3", 4", 5", 6"

H'S

6" × 6" and 8" × 8"

EXPLANATORY NOTES

Material Included. This hand-book includes all the American Standard Structural Shapes as adopted by the Association of American Steel Manufacturers, comprising I-beams, structural channels, angles, shipbuilding channels and shipbuilding bulb angles.

In addition to the Standard Shapes, information is also given concerning Phoenix Beams, Tees, Zees, H-columns and various sizes of angles, other than standard angles, which are marked "Special."

General Conditions. All sections shown herein are of open hearth steel, conforming to the Manufacturers Standard Specifications, and to those of the American Society for Testing Materials.

The weights and dimensions given are theoretical, and subject to the usual variations.

Weights of sections are stated in pounds per foot, and are calculated on the basis of 489.6 pounds per cubic foot of steel; 3.4 times the sectional area in square inches equals the weight in pounds per lineal foot.

In ordering shapes, the thickness or the weight per foot should be given, but not both. The weights and thicknesses given in the tables should be adhered to.

Shapes are billed at the catalogue weights.

Areas and Weights. The manner of increasing the areas and weights of the various sections is illustrated on Page 6.

The areas and weights of I-beams, channels and H-columns are increased from the minimum, as shown by Figures 1 and 2, whereby an equal amount is added to the thickness of the web and the widths of the flanges, the other dimensions remaining unchanged.

Angles. The areas and weights of angles are increased as shown in Figure 3, by adding equally to the thickness of each leg.

Bulb Angles. The areas and weights of shipbuilding bulb angles are increased from the minimum, as shown in Figure 4, and are based upon a method which increases the thickness of the web to an extent twice as great as that of the flange. The usual increment of the web thickness is 0.06 inch, while that of the flange is 0.03 inch, corresponding approximately to $\frac{1}{16}$ inch and $\frac{1}{32}$ inch respectively. This slightly increases the overall length of the flange, and, to a lesser extent, the depth of the section, as shown in Figure 4.

The properties of shipbuilding bulb angles and their areas are based upon the exact profiles.

Zees and Tees. Areas and weights of Zee bars are increased as shown in Figure 5. Tee bars can only be rolled to weights given.

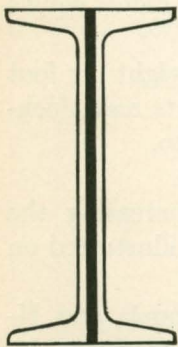

Fig. 1



Fig. 3

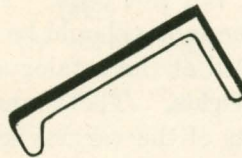

Fig. 4

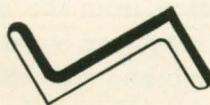

Fig. 5



Fig. 2

GENERAL DIMENSIONS OF AMERICAN STANDARD I BEAMS AND CHANNELS

Adopted by The Association of American Steel Manufacturers

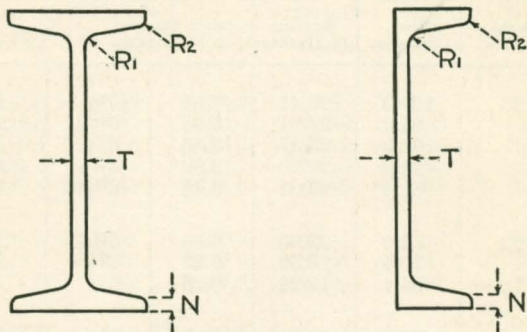

The following data are common to all American Standard I Beams and Channels, with the exceptions stated:

R_1 = Minimum Web + $\frac{1}{10}$ inch.

R_2 = $\frac{6}{10}$ Minimum Web.

N = Minimum Thickness of Web = T Minimum for all Channels and I Beams, except 24" I and 20" I.

For 24" Standard I, N = .60", T Minimum = .50".

For 20" Standard I, N = .55", T Minimum = .50".

Slope of flange of all Standard I Beams and Structural Channels = $16\frac{2}{3}\%$ = $9^\circ 27' 44''$ = 2" per foot.

The following data are common to all American Standard Shipbuilding Channels:

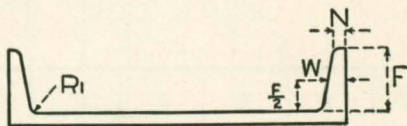

$$N = W - .01746 F$$

$$R_1 = W$$

Slope of flange of Shipbuilding Channels = $2^\circ = 3.492\%$.

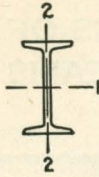

1931

PROPERTIES
OF
BEAMS

Section Number	Depth of Beam, Inches	Weight per Foot, Pounds	Area of Section, Sq. Inches	Width of Flange, Inches		Thickness of Web, Inches	
208	20	100.0	29.41	7.02	$7\frac{1}{32}$.87	$\frac{7}{8}$
		95.0	27.94	6.95	$6\frac{15}{16}$.80	$\frac{13}{16}$
		90.0	26.47	6.88	$6\frac{7}{8}$.73	$\frac{23}{32}$
		85.0	25.00	6.80	$6\frac{13}{16}$.65	$\frac{21}{32}$
		81.4	23.94	6.75	$6\frac{3}{4}$.60	$\frac{19}{32}$
206	20	75.0	22.06	6.39	$6\frac{13}{32}$.64	$\frac{21}{32}$
		70.0	20.59	6.32	$6\frac{5}{16}$.57	$\frac{9}{16}$
		65.4	19.24	6.25	$6\frac{1}{4}$.50	$\frac{1}{2}$
207	18	70.0	20.59	6.25	$6\frac{1}{4}$.71	$\frac{23}{32}$
		65.0	19.12	6.17	$6\frac{5}{32}$.63	$\frac{5}{8}$
		60.0	17.65	6.09	$6\frac{3}{32}$.55	$\frac{17}{32}$
		54.7	16.09	6.00	6	.46	$\frac{15}{32}$

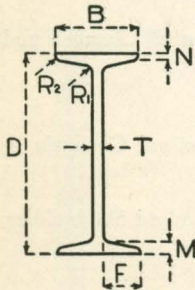

DIMENSIONS
OF
MINIMUM BEAM SECTIONS

Section Number	Depth D	Weight	B	T	F	M	N	R ₁	R ₂
208	20	81.4	6.75	.60	3.075	1.250	.65	.70	.36
206	20	65.4	6.25	.50	2.875	1.029	.55	.60	.30
207	18	54.7	6.00	.46	2.770	.922	.46	.56	.28

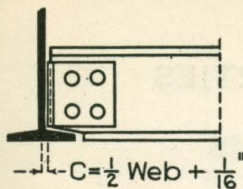

PROPERTIES OF BEAMS

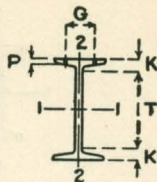

Resisting Moment in Foot Pounds at 18,000 lbs. per Sq. Inch	AXIS 1-1			AXIS 2-2			Depth of Beam, Inches
	Moment of Inertia	Radius of Gyration	Section Modulus	Moment of Inertia	Radius of Gyration	Section Modulus	
247,350	1648.6	7.49	164.9	48.68	1.29	13.87	20
240,000	1599.5	7.57	160.0	46.89	1.30	13.49	
232,650	1550.5	7.65	155.1	45.17	1.31	13.13	
225,300	1501.5	7.75	150.2	43.50	1.32	12.79	
219,900	1466.2	7.83	146.6	42.35	1.33	12.55	
190,350	1268.8	7.58	126.9	30.24	1.17	9.47	20
183,000	1219.7	7.70	122.0	29.04	1.19	9.20	
176,250	1174.6	7.81	117.5	27.98	1.21	8.95	
153,600	921.3	6.69	102.4	24.64	1.09	7.89	18
147,000	881.6	6.79	98.0	23.60	1.11	7.65	
140,250	841.9	6.91	93.5	22.52	1.13	7.39	
133,350	799.8	7.05	88.9	21.42	1.15	7.14	

BEAM CONNECTIONS

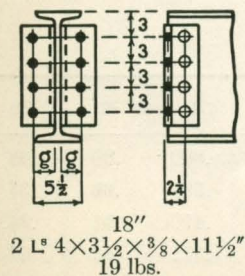
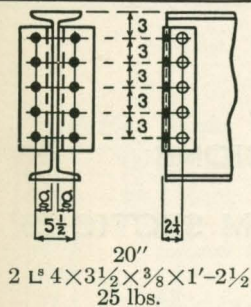

Gauge G, Inches	Tangent T, Inches	Distance K, Inches	Grip P, Inches	Max. Rivet in Flange	Wall Bearing	Wall Plates	Gauge g, Inches	Dist. C, Inches	Weight per Foot	Depth
4	16½	1¾	1⅝	⅞	16	16 × 1 × 16	2⅝/16	1/2	100.0	20
						73 lbs.	2⅜/8	7/16	95.0	
						16 × 1 × 16	2⅜/8	1/16	90.0	
						73 lbs.	2⅜/8	3/8	85.0	
						16 × 1 × 16	2⅜/16	3/8	81.4	
3½	17	1½	1⅜	⅞	16	16 × 1 × 16	27/16	3/8	75.0	20
						73 lbs.	27/16	3/8	70.0	
						16 × 1 × 16	21/2	5/16	65.4	
3½	15¼	1⅜	1⅝	⅞	16	16 × 1 × 16	2⅜/8	7/16	70.0	18
						73 lbs.	27/16	3/8	65.0	
						16 × 1 × 16	21/2	5/16	60.0	
						73 lbs.	21/2	5/16	54.7	
						16 × 1 × 16	21/2	3/16	54.7	

All rivets in standard connection angles are ¼" diam. Weights of standard connections include the shop rivets, but no field rivets.

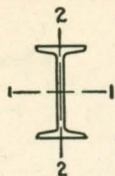

PROPERTIES
OF
BEAMS

193)

Section Number	Depth of Beam, Inches	Weight per Foot, Pounds	Area of Section, Sq. Inches	Width of Flange, Inches		Thickness of Web, Inches	
161	15	100.0	29.41	6.77	$6\frac{25}{32}$	1.17	$1\frac{5}{32}$
		95.0	27.94	6.67	$6\frac{21}{32}$	1.07	$1\frac{1}{16}$
		90.0	26.47	6.57	$6\frac{9}{16}$.97	$\frac{31}{32}$
		85.0	25.00	6.47	$6\frac{15}{32}$.87	$\frac{7}{8}$
		81.3	23.91	6.40	$6\frac{13}{32}$.80	$1\frac{3}{16}$
162	15	75.0	22.06	6.28	$6\frac{9}{32}$.87	$\frac{7}{8}$
		70.0	20.59	6.18	$6\frac{3}{16}$.77	$\frac{25}{32}$
		65.0	19.12	6.08	$6\frac{3}{32}$.67	$\frac{11}{16}$
		60.8	17.88	6.00	6	.59	$1\frac{9}{32}$
164	15	55.0	16.18	5.74	$5\frac{3}{4}$.65	$\frac{21}{32}$
		50.0	14.71	5.64	$5\frac{5}{8}$.55	$\frac{9}{16}$
		45.0	13.24	5.54	$5\frac{17}{32}$.45	$\frac{7}{16}$
		42.9	12.62	5.50	$5\frac{1}{2}$.41	$1\frac{3}{32}$
*252 * Special	15	36.0	10.59	5.50	$5\frac{1}{2}$.29	$\frac{9}{32}$

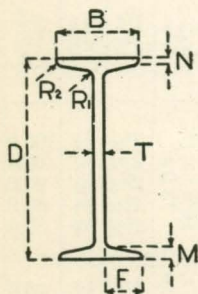

DIMENSIONS
OF
MINIMUM BEAM SECTIONS

Section Number	Depth D	Weight	B	T	F	M	N	R ₁	R ₂
161	15	81.3	6.40	.800	2.800	1.267	.800	.90	.48
162	15	60.8	6.00	.590	2.705	1.041	.590	.69	.35
164	15	42.9	5.50	.410	2.545	.834	.410	.51	.25
*252	15	36.0	5.50	.289	2.606	.805	.371	.45	.06

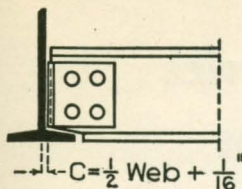

PROPERTIES OF BEAMS

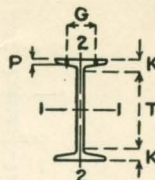

Resisting Moment in Foot Pounds at 18,000 lbs. Per Sq. Inch	AXIS 1-1			AXIS 2-2			Depth of Beam, Inches
	Moment of Inertia	Radius of Gyration	Section Modulus	Moment of Inertia	Radius of Gyration	Section Modulus	
179,700	898.6	5.53	119.8	50.30	1.31	14.86	15
174,150	871.1	5.58	116.1	47.74	1.31	14.32	
168,750	843.5	5.65	112.5	45.30	1.31	13.79	
163,200	815.9	5.71	108.8	42.96	1.31	13.28	
159,150	795.5	5.77	106.1	41.31	1.31	12.91	
138,300	691.3	5.60	92.2	30.46	1.18	9.70	15
132,750	663.7	5.68	88.5	28.79	1.18	9.31	
127,200	636.1	5.77	84.8	27.22	1.19	8.95	
122,550	612.9	5.86	81.7	25.96	1.21	8.65	
102,150	511.0	5.62	68.1	16.97	1.02	5.91	
96,750	483.4	5.73	64.5	15.96	1.04	5.66	
91,200	455.8	5.87	60.8	15.00	1.06	5.42	
88,800	444.3	5.93	59.2	14.62	1.08	5.32	
80,100	400.9	6.15	53.4	13.50	1.13	4.91	15

BEAM CONNECTIONS

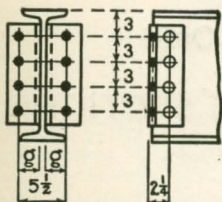

15"
2 L⁴ 4 × 3 1/2 × 3/8
11 1/2" long
19 lbs.

Gauge G, Inches	Tangent T, Inches	Distance K, Inches	Grip P, Inches	Max Rivet in Flange	Wall Bearing	Wall Plates	Gauge G, Inches	Dist. C, Inches	Weight per Foot	Depth
3 3/4	11	2	1 1/16	7/8	16	16 × 1 × 16	23/16	5/8	100.0	15
							23/16	9/16	95.0	
							2 1/4	9/16	90.0	
							23/16	1/2	85.0	
							23/16	1/2	81.3	
3 1/2	11 3/4	1 5/8	1 3/16	7/8	16	16 × 1 × 16	23/16	1/2	75.0	15
							2 3/8	7/16	70.0	
							2 1/16	1/16	65.0	
							2 1/16	3/8	60.8	
3	12 1/2	1 1/4	5/8	7/8	12	12 × 1 × 16	27/16	3/8	55.0	15
							2 1/2	3/8	50.0	
							2 1/2	1/4	45.0	
							23/16	1/4	42.9	
3	12 5/8	1 3/16	5/8	7/8	12	12 × 1 × 16	2 5/8	3/16	36.0	15
							54 lbs.			

All rivets in standard connections are 3/4" diameter. Weights of standard connections include the shop rivets, but no field rivets.

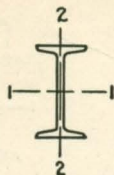

PROPERTIES
OF
BEAMS

193

Section Number	Depth of Beam, Inches	Weight per Foot, Pounds	Area of Section, Sq. Inches	Width of Flange, Inches		Thickness of Web, Inches	
165	12	55.0	16.18	5.60	$5\frac{19}{32}$.81	$\frac{13}{16}$
		50.0	14.71	5.48	$5\frac{15}{32}$.69	$\frac{11}{16}$
		45.0	13.24	5.35	$5\frac{11}{32}$.56	$\frac{9}{16}$
		40.8	12.00	5.25	$5\frac{1}{4}$.46	$\frac{15}{32}$
166	12	35.0	10.29	5.08	$5\frac{3}{32}$.43	$\frac{7}{16}$
		31.8	9.35	5.00	5	.35	$\frac{11}{32}$
*288	12	27.5	8.09	5.06	$5\frac{1}{16}$.30	$\frac{5}{16}$
		25.0	7.35	5.00	5	.24	$\frac{1}{4}$
221	10	40.0	11.76	5.09	$5\frac{3}{32}$.74	$\frac{3}{4}$
		35.0	10.29	4.94	$4\frac{15}{16}$.59	$\frac{19}{32}$
		30.0	8.82	4.80	$4\frac{29}{32}$.45	$\frac{7}{16}$
		25.4	7.47	4.66	$4\frac{21}{32}$.31	$\frac{5}{16}$
*289	10	21.0	6.18	5.74	$5\frac{3}{4}$.24	$\frac{1}{4}$
*Special							

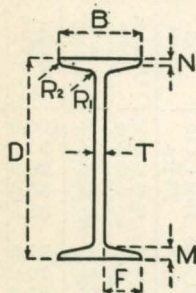

DIMENSIONS
OF
MINIMUM BEAM SECTIONS

Section Number	Depth D	Weight	B	T	F	M	N	R ₁	R ₂
165	12	40.8	5.25	.46	2.395	.859	.460	.56	.28
166	12	31.8	5.00	.35	2.325	.738	.350	.45	.21
*288	12	25.0	5.00	.24	2.38	.662	.265	.40	.16
221	10	25.4	4.66	.31	2.175	.673	.310	.41	.19
*289	9.90	21.0	5.74	.24	2.75	.464	.235	.30	.03

PROPERTIES OF BEAMS

Section Number	Depth of Beam, Inches	Weight per Foot, Pounds	Area of Section, Sq. Inches	Width of Flange, Inches		Thickness of Web, Inches	
*299	12	28.0	8.24	6.569	$6\frac{9}{16}$.314	$\frac{5}{16}$
		25.0	7.35	6.495	$6\frac{1}{2}$.240	$\frac{1}{4}$

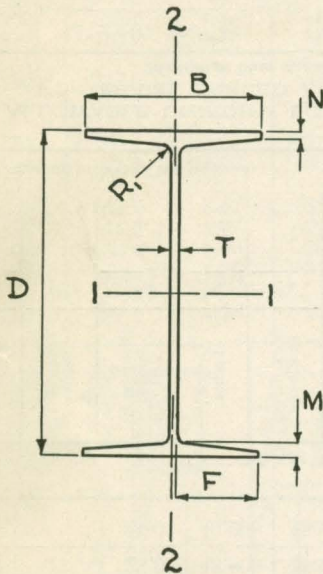

DIMENSIONS OF MINIMUM BEAM SECTION

Section Number	Depth D	Weight	B	T	F	M	N	R ₁	R ₂
*299	11.875	25.00	6.495	.24	3.128	.485	.225	.35	—

PROPERTIES OF BEAMS

Section Number	Depth of Beam, Inches	Weight per Foot, Pounds	Resisting Moment in Foot-Pounds at 18,000 lbs. per Sq. Inch	AXIS 1-1			AXIS 2-2		
				Moment of Inertia	Radius of Gyration	Section Modulus	Moment of Inertia	Radius of Gyration	Section Modulus
*299	12	28.0	48,900	193.6	4.85	32.6	13.9	1.30	4.28
		25.0	46,200	182.8	4.98	30.8	13.4	1.35	4.12

BEAM CONNECTIONS

Gauge G, Inches	Tangent T, Inches	Distance K, Inches	Grip P, Inches	Max. Rivet in Flange	Wall Bearing	Wall Plates	Gauge E, Inches	Dist. C, Inches	Weight per Foot	Depth
3½	10¼	13½	⅜	¾	12	12	2⅞	¼	28.0	12
						12 × ¾ × 31 lbs.	2⅝	⅜	25.0	

For meaning of letters see page 13.

ALLOWABLE UNIFORM LOADS IN THOUSANDS OF POUNDS FOR BEAMS BRACED AGAINST LATERAL DEFLECTION Maximum fiber stress, 18,000 pounds per square inch

Span in Feet	12" I NO. 299		Span in Feet	12" I NO. 299		Span in Feet	12" I NO. 299	
	28 lbs.	25 lbs.		28 lbs.	25 lbs.		28 lbs.	25 lbs.
10	39.1	37.0	19	20.6	19.4	28	14.0	13.2
11	35.6	33.6	20	19.6	18.5	29	13.5	12.7
12	32.6	30.8	21	18.6	17.6	30	13.0	12.3
13	30.1	28.4	22	17.8	16.8	31	12.6	11.9
14	28.0	26.4	23	17.0	16.1	32	12.2	11.5
15	26.1	24.6	24	16.3	15.4	33	11.9	11.2
16	24.5	23.1	25	15.7	14.8	34	11.5	10.9
17	23.0	21.7	26	15.1	14.2	35	11.2	10.6
18	21.7	20.5	27	14.5	13.7	36	10.9	10.3

Special connection angles must be used for loads above the dotted line.

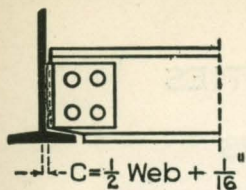

PROPERTIES OF BEAMS

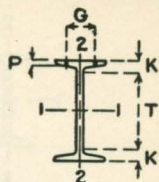

Resisting Moment in Foot Pounds at 18,000 lbs. per Sq. Inch	AXIS 1-1			AXIS 2-2			Depth of Beam, Inches
	Moment of Inertia	Radius of Gyration	Section Modulus	Moment of Inertia	Radius of Gyration	Section Modulus	
80,250	321.0	4.45	53.5	17.29	1.03	6.17	12
75,900	303.3	4.54	50.6	15.98	1.04	5.83	
71,400	285.7	4.65	47.6	14.75	1.06	5.52	
67,650	270.9	4.75	45.1	13.79	1.07	5.25	
57,150	228.3	4.71	38.1	10.02	.99	3.94	12
54,300	217.0	4.82	36.2	9.50	1.01	3.80	
47,550	190.3	4.85	31.7	8.01	.99	3.17	12
45,450	181.5	4.97	30.3	7.71	1.02	3.08	
47,550	158.7	3.67	31.7	9.40	.89	3.69	10
43,950	146.5	3.77	29.3	8.46	.91	3.42	
40,200	134.2	3.90	26.8	7.61	.93	3.17	
36,900	122.9	4.06	24.6	6.89	.96	2.96	
32,550	107.5	4.17	21.7	9.30	1.22	3.24	10

BEAM CONNECTIONS

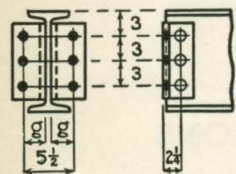

12"
2 L 4 × 3½ × ⅜ × 8½"
14 lbs.

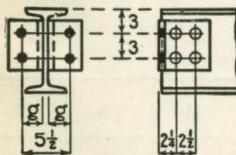

10"
2 L 6 × 4 × ⅜ × 5½"
13 lbs.

Gauge G, Inches	Tangent T, Inches	Distance K, Inches	Grip P, Inches	Max. Rivet in Flange	Wall Bearing	Wall Plates	Gauge g, Inches	Dist. C, Inches	Weight per Foot	Depth
3	9¼	1⅜	1⅛	¾	12	12 × ¾ × 12	2⅜/8 2⅞/8 27/16 2½	1½ 1⅛ 3/8 5/16	55.0 50.0 45.0 40.8	12
2¾	9¾	1⅞	9/16	¾	12	12 × ¾ × 12	29/16 29/16	1¼ ¼	35.0 31.8	12
2¾	9¾	1⅞	½	¾	12	12 × ¾ × 12	29/16 29/8	1¼ 3/16	27.5 25.0	12
2½	8	1	½	¾	8	8 × ¾ × 12	23/8 27/16 2½	7/16 3/8 5/16 ¼	40.0 35.0 30.0 25.4	10
3	8	1	3/8	¾	8	8 × ¾ × 12	25/8	3/16	21.0	10

All rivets in standard connections are ¾" diameter. Weights of standard connections include the shop rivets, but no field rivets.

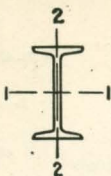

PROPERTIES OF BEAMS

1931

Section Number	Depth of Beam, Inches	Weight per Foot, Pounds	Area of Section, Sq. Inches	Width of Flange, Inches		Thickness of Web, Inches	
209	9	35.0	10.29	4.76	$4\frac{3}{4}$.72	$\frac{23}{32}$
		30.0	8.82	4.60	$4\frac{19}{32}$.56	$\frac{9}{16}$
		25.0	7.35	4.43	$4\frac{7}{16}$.39	$\frac{13}{32}$
		21.8	6.41	4.33	$4\frac{11}{32}$.29	$\frac{9}{32}$
210	8	25.5	7.50	4.26	$4\frac{1}{4}$.53	$\frac{17}{32}$
		23.0	6.76	4.17	$4\frac{5}{32}$.44	$\frac{7}{16}$
		20.5	6.03	4.08	$4\frac{1}{16}$.35	$\frac{11}{32}$
		18.4	5.41	4.00	4	.27	$\frac{9}{32}$
*298	8	21.0	6.18	5.40	$5\frac{13}{32}$.38	$\frac{3}{8}$
		19.0	5.59	5.32	$5\frac{5}{16}$.31	$\frac{5}{16}$
		17.0	5.00	5.25	$5\frac{1}{4}$.24	$\frac{1}{4}$
211	7	20.0	5.88	3.86	$3\frac{27}{32}$.45	$\frac{7}{16}$
		17.5	5.15	3.75	$3\frac{3}{4}$.34	$\frac{11}{32}$
		15.3	4.50	3.66	$3\frac{21}{32}$.25	$\frac{1}{4}$

*Special

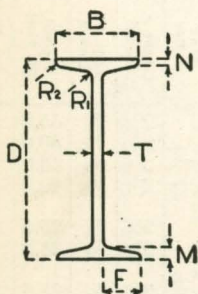

DIMENSIONS OF MINIMUM BEAM SECTIONS

Section Number	Depth D	Weight	B	T	F	M	N	R ₁	R ₂
209	9	21.8	4.33	.29	2.020	.627	.29	.39	.17
210	8	18.4	4.00	.27	1.865	.581	.27	.37	.16
*298	8	17.0	5.25	.24	2.508	.409	.20	.30	.03
211	7	15.3	3.66	.25	1.705	.534	.25	.35	.15

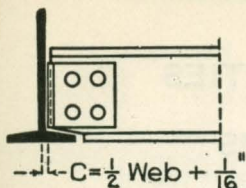

PROPERTIES OF BEAMS

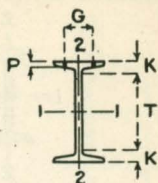

Resisting Moment in Foot Pounds at 18,000 lbs. per Sq. Inch	AXIS 1-1			AXIS 2-2			Depth of Beam, Inches
	Moment of Inertia	Radius of Gyration	Section Modulus	Moment of Inertia	Radius of Gyration	Section Modulus	
37,200	111.8	3.30	24.8	7.21	.84	3.03	9
33,900	101.9	3.40	22.6	6.37	.85	2.77	
30,600	92.0	3.54	20.4	5.60	.87	2.53	
28,500	85.6	3.65	19.0	5.16	.90	2.38	
25,650	68.4	3.02	17.1	4.71	.79	2.21	8
24,150	64.5	3.09	16.1	4.37	.81	2.10	
22,800	60.6	3.17	15.2	4.04	.82	1.98	
21,450	57.3	3.25	14.3	3.78	.84	1.89	
23,400	62.3	3.18	15.6	6.80	1.05	2.52	8
22,200	59.2	3.26	14.8	6.45	1.08	2.42	
21,000	56.0	3.35	14.0	6.16	1.11	2.35	
18,150	42.2	2.68	12.1	3.21	.74	1.66	7
16,800	39.2	2.76	11.2	2.91	.75	1.55	
15,600	36.5	2.85	10.4	2.67	.77	1.46	

BEAM CONNECTIONS

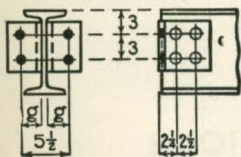

9" and 8"
 2 L^s 6 × 4 × 3/8
 × 5 1/2"
 13 lbs.

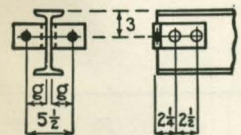

7"
 2 L^s 6 × 4 × 3/8
 × 2 1/2"
 6 lbs.

Gauge G, Inches	Tangent T, Inches	Distance K, Inches	Grip P, Inches	Max. Rivet in Flange	Wall Bearing	Wall Plates	Gauge G, Inches	Dist. C, Inches	Weight per Foot, lbs.	Depth
2 1/2	7	1	7/16	3/4	8	8 × 5/8 × 12 17 lbs.	23/8 21/2 29/16 25/8	7/16 3/8 1/4 3/16	35.0 30.0 25.0 21.8	9
2 1/4	6 1/4	7/8	7/16	3/4	8	8 × 5/8 × 8 11 lbs.	21/2 21/2 29/16 25/8	5/16 5/16 1/4 3/16	25.5 23.0 20.5 18.4	8
2 1/4	6 5/8	1 1/16	5/16	3/4	8	8 × 5/8 × 8 11 lbs.	29/16 219/32 25/8	1/4 7/32 3/16	21.0 19.0 17.0	8
2 1/4	5 1/4	7/8	3/8	5/8	8	8 × 5/8 × 8 11 lbs.	21/2 29/16 25/8	5/16 1/4 3/16	20.0 17.5 15.3	7

All rivets in standard connections are 3/4" diameter. Weights of standard connections include the shop rivets, but no field rivets.

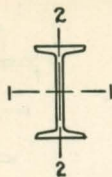

1931

PROPERTIES OF BEAMS

Section Number	Depth of Beam, Inches	Weight per Foot, Pounds	Area of Section, Sq. Inches	Width of Flange, Inches		Thickness of Web, Inches	
212	6	17.25	5.07	3.56	$3\frac{9}{16}$.46	$1\frac{5}{32}$
		14.75	4.34	3.44	$3\frac{7}{16}$.34	$1\frac{1}{32}$
		12.5	3.68	3.33	$3\frac{11}{32}$.23	$\frac{7}{32}$
214	5	14.75	4.34	3.28	$3\frac{9}{32}$.49	$\frac{1}{2}$
		12.25	3.60	3.13	$3\frac{1}{8}$.34	$1\frac{1}{32}$
		10.0	2.94	3.00	3	.21	$\frac{7}{32}$
213	4	10.5	3.09	2.87	$2\frac{7}{8}$.40	$1\frac{3}{32}$
		9.5	2.79	2.79	$2\frac{25}{32}$.32	$\frac{5}{16}$
		8.5	2.50	2.72	$2\frac{23}{32}$.25	$\frac{1}{4}$
		7.7	2.26	2.66	$2\frac{21}{32}$.19	$\frac{3}{16}$
222	3	7.5	2.21	2.51	$2\frac{1}{2}$.35	$1\frac{1}{32}$
		6.5	1.91	2.41	$2\frac{13}{32}$.25	$\frac{1}{4}$
		5.7	1.68	2.33	$2\frac{11}{32}$.17	$\frac{5}{32}$

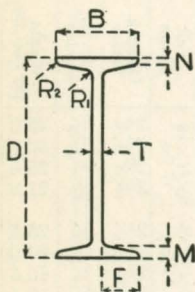

DIMENSIONS OF MINIMUM BEAM SECTIONS

Section Number	Depth D	Weight	B	T	F	M	N	R ₁	R ₂
212	6	12.5	3.33	.23	1.550	.488	.23	.33	.14
214	5	10.0	3.00	.21	1.395	.443	.21	.31	.13
213	4	7.7	2.66	.19	1.235	.396	.19	.29	.11
222	3	5.7	2.33	.17	1.080	.350	.17	.27	.10

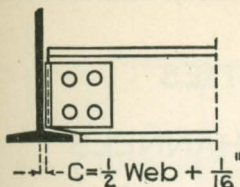

PROPERTIES OF BEAMS

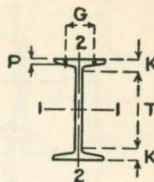

Resisting Moment in Foot Pounds at 18,000 lbs. per Sq. Inch	AXIS 1-1			AXIS 2-2			Depth of Beam, Inches	
	Moment of Inertia	Radius of Gyration	Section Modulus	Moment of Inertia	Radius of Gyration	Section Modulus		
13,050	26.2	2.27	8.7	2.34	.68	1.31	6	
12,000	24.0	2.35	8.0	2.07	.69	1.20		
10,950	22.0	2.43	7.3	1.85	.71	1.11		
9,150	15.2	1.87	6.1	1.68	.62	1.02		5
8,100	13.6	1.94	5.4	1.43	.63	.91		
7,350	12.2	2.04	4.9	1.23	.65	.82		
5,400	7.1	1.52	3.6	1.01	.57	.70	4	
5,100	6.8	1.56	3.4	.93	.58	.67		
4,800	6.4	1.60	3.2	.85	.58	.62		
4,500	6.0	1.63	3.0	.79	.59	.59		
2,850	2.9	1.14	1.9	.59	.52	.47		3
2,700	2.7	1.19	1.8	.52	.52	.43		
2,550	2.5	1.22	1.7	.46	.52	.40		

BEAM CONNECTIONS

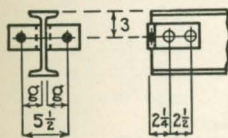

6" and 5"
2 L^s 6 × 4 × 3/8 × 2 1/2"
6 lbs.

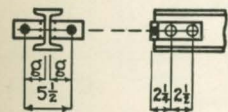

4" and 3"
2 L^s 6 × 4 × 3/8 × 2"
5 lbs.

Gauge G, Inches	Tangent T, Inches	Distance K, Inches	Grip P, Inches	Max. Rivet in Flange	Wall Bearing	Wall Plates	Gauge G, Inches	Dist. C, Inches	Weight per Foot	Depth
2	4 1/2	3/4	3/8	5/8	6	6 × 1/2 × 6 5 lbs.	2 1/2 29/16 2 5/8	5/16 1/4 3/16	17.25 14.75 12.5	6
1 3/4	3 1/2	3/4	3/8	1/2	6	6 × 1/2 × 6 5 lbs.	2 1/2 29/16 2 5/8	5/16 1/4 3/16	14.75 12.25 10.0	5
1 1/2	2 3/4	5/8	5/16	1/2	6	6 × 1/2 × 6 5 lbs.	29/16 29/16 2 5/8	1/4 1/4 3/16	10.5 9.5 8.5 7.7	4
1 1/2	1 3/4	5/8	1/4	3/8	6	6 × 1/2 × 6 5 lbs.	29/16 2 5/8 2 11/16	1/4 3/16 1/8	7.5 6.5 5.7	3

All rivets in standard connections are 3/4" diameter. Weights of standard connections include the shop rivets, but no field rivets.

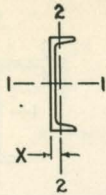

PROPERTIES OF STANDARD CHANNELS

Section Number	Depth of Channel, Inches	Weight per Foot, Pounds	Area of Section, Sq. Inches	Width of Flange, Inches		Thickness of Web, Inches	
140	15	55.0	16.18	3.81	$3\frac{13}{16}$.81	$\frac{13}{16}$
		50.0	14.71	3.72	$3\frac{23}{32}$.72	$\frac{23}{32}$
		45.0	13.24	3.62	$3\frac{5}{8}$.62	$\frac{5}{8}$
		40.0	11.76	3.52	$3\frac{17}{32}$.52	$\frac{17}{32}$
		35.0	10.29	3.42	$3\frac{13}{32}$.42	$\frac{13}{32}$
		33.9	9.97	3.40	$3\frac{13}{32}$.40	$\frac{13}{32}$
141	12	40.0	11.76	3.41	$3\frac{13}{32}$.75	$\frac{3}{4}$
		35.0	10.29	3.29	$3\frac{9}{32}$.63	$\frac{5}{8}$
		30.0	8.82	3.17	$3\frac{5}{32}$.51	$\frac{1}{2}$
		25.0	7.35	3.05	$3\frac{1}{32}$.39	$\frac{3}{8}$
		20.7	6.09	2.94	$2\frac{15}{16}$.28	$\frac{9}{32}$

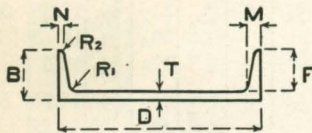

DIMENSIONS OF MINIMUM CHANNEL SECTIONS

Section Number	Depth D	Weight	B	T	F	M	N	R ₁	R ₂
140	15	33.9	3.40	.40	3.00	.900	.40	.50	.24
141	12	20.7	2.94	.28	2.66	.723	.28	.38	.17

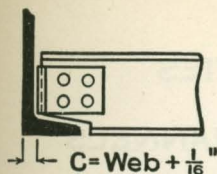

PROPERTIES OF STANDARD CHANNELS

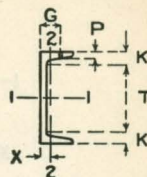

Resisting Moment in Foot Pounds at 18,000 lbs. per Sq. Inch	AXIS 1-1			AXIS 2-2				Depth of Channel, Inches
	Moment of Inertia	Radius of Gyration	Section Modulus	Moment of Inertia	Radius of Gyration	Section Modulus	Location of Center of Gravity X	
86,100	430.2	5.16	57.4	12.1	.87	4.1	.82	15
80,550	402.7	5.23	53.7	11.2	.87	3.8	.80	
75,000	375.1	5.32	50.0	10.3	.88	3.6	.79	
69,450	347.5	5.44	46.3	9.3	.89	3.4	.78	
64,050	319.9	5.58	42.7	8.4	.91	3.2	.79	
62,700	313.9	5.61	41.8	8.2	.91	3.2	.79	
49,200	196.9	4.09	32.8	6.6	.75	2.5	.72	12
44,850	179.3	4.17	29.9	5.9	.76	2.3	.69	
40,350	161.6	4.28	26.9	5.2	.77	2.1	.68	
36,000	144.0	4.43	24.0	4.5	.78	1.9	.68	
32,250	128.8	4.60	21.5	3.9	.80	1.7	.70	

CHANNEL CONNECTIONS

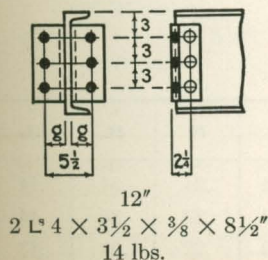
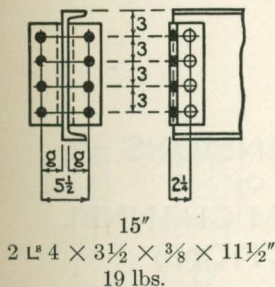

Gauge G, Inches	Tangent T, Inches	Distance K, Inches	Grip P, Inches	Max. Rivet in Flange, Inches	Wall Bearing	Wall Plates	Gauge g, Inches	Dist. C, Inches	Weight per Foot	Depth
2 1/4	12 1/4	1 3/8	1 1/16	7/8	12	16	2 5/16	7/8	55.0	15
2 1/4		1 1/16	1 1/16	7/8	12	16	2 3/8	1 3/16	50.0	
2		1 1/16	1 1/16	7/8	12	16	2 7/16	1 1/16	45.0	
2		1 1/16	1 1/16	7/8	12	16	2 1/2	5/8	40.0	
2		1 1/16	1 1/16	7/8	12	16	2 9/16	1/2	35.0	
2		1 1/16	1 1/16	7/8	12	16	2 9/16	1/2	33.9	
2	10	1	1/2	7/8	12	12	2 3/8	1 3/16	40.0	12
2		1/2	1/2	7/8	12	12	2 7/16	1 1/16	35.0	
2		1/2	1/2	7/8	12	12	2 1/2	9/16	30.0	
1 3/4		1/2	1/2	7/8	12	12	2 9/16	7/16	25.0	
1 3/4		1/2	1/2	7/8	12	12	2 5/8	3/8	20.7	

All rivets in standard connections are 3/4" diameter. Weights of standard connections include the shop rivets but not the field rivets.

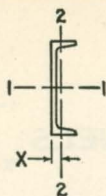

PROPERTIES OF STANDARD CHANNELS

Section Number	Depth of Channel, Inches	Weight per Foot, Pounds	Area of Section, Sq. Inches	Width of Flange, Inches		Thickness of Web, Inches	
130	10	35.0	10.29	3.18	$3\frac{3}{16}$.82	$1\frac{3}{16}$
		30.0	8.82	3.03	$3\frac{1}{32}$.67	$1\frac{1}{16}$
		25.0	7.35	2.89	$2\frac{7}{8}$.53	$1\frac{17}{32}$
		20.0	5.88	2.74	$2\frac{3}{4}$.38	$\frac{3}{8}$
		15.3	4.50	2.60	$2\frac{19}{32}$.24	$\frac{1}{4}$
233	9	25.0	7.35	2.81	$2\frac{13}{16}$.61	$1\frac{19}{32}$
		20.0	5.88	2.65	$2\frac{21}{32}$.45	$\frac{7}{16}$
		15.0	4.41	2.48	$2\frac{15}{32}$.28	$\frac{9}{32}$
		13.4	3.94	2.43	$2\frac{7}{16}$.23	$\frac{7}{32}$
122	8	21.25	6.25	2.62	$2\frac{5}{8}$.58	$1\frac{19}{32}$
		18.75	5.51	2.53	$2\frac{17}{32}$.49	$\frac{1}{2}$
		16.25	4.78	2.43	$2\frac{7}{16}$.39	$1\frac{13}{32}$
		13.75	4.04	2.34	$2\frac{11}{32}$.30	$\frac{5}{16}$
		11.50	3.38	2.26	$2\frac{1}{4}$.22	$\frac{7}{32}$

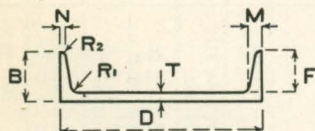

DIMENSIONS OF MINIMUM CHANNEL SECTIONS

Section Number	Depth D	Weight	B	T	F	M	N	R ₁	R ₂
130	10	15.3	2.60	.24	2.36	.633	.24	.34	.14
233	9	13.4	2.43	.23	2.20	.597	.23	.33	.14
122	8	11.5	2.26	.22	2.04	.560	.22	.32	.13

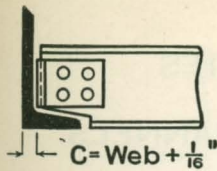

PROPERTIES OF STANDARD CHANNELS

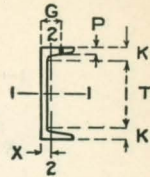

Resisting Moment in Foot Pounds at 18,000 lbs. per Sq. Inch	AXIS 1-1			AXIS 2-2				Depth of Channel, Inches
	Moment of Inertia	Radius of Gyration	Section Modulus	Moment of Inertia	Radius of Gyration	Section Modulus	Location of Center of Gravity X	
34,650	115.5	3.35	23.1	4.6	.67	1.9	.69	10
30,900	103.2	3.42	20.6	4.0	.67	1.7	.65	
27,300	91.0	3.52	18.2	3.4	.68	1.5	.62	
23,550	78.7	3.66	15.7	2.8	.69	1.3	.61	
20,100	67.2	3.86	13.4	2.3	.72	1.2	.64	
23,550	70.7	3.10	15.7	3.0	.63	1.4	.61	9
20,250	60.8	3.22	13.5	2.4	.64	1.2	.58	
16,950	50.9	3.40	11.3	1.9	.66	1.0	.59	
15,900	47.7	3.48	10.6	1.8	.67	.97	.61	
17,850	47.8	2.76	11.9	2.2	.60	1.10	.59	
16,500	43.8	2.82	11.0	2.0	.60	1.02	.57	8
15,000	39.9	2.89	10.0	1.8	.61	.94	.56	
13,500	36.0	2.99	9.0	1.5	.62	.86	.56	
12,150	32.5	3.10	8.1	1.3	.63	.79	.58	

CHANNEL CONNECTIONS

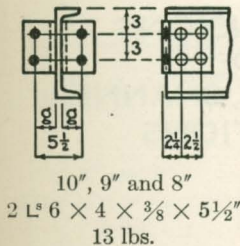

Gauge G, Inches	Tangent T, Inches	Distance K, Inches	Grip P, Inches	Max. Rivet in Flange	Wall Bearing	Wall Plates	Gauge g, Inches	Dist. C, Inches	Weight per Foot	Depth
2	8 1/4	7/8	7/16	3/4	8	8 x 3/4 x 12 20 lbs.	2 3/8	7/8	35.0	10
1 7/8							3/4	30.0		
1 3/4							5/8	25.0		
1 1/2							7/16	20.0		
1 1/2							7/16	15.3		
1 3/4	7 1/4	7/8	7/16	3/4	8	8 x 5/8 x 12 17 lbs.	2 7/16	1 1/16	25.0	9
1 1/2							1 1/2	20.0		
1 3/8							3/8	15.0		
1 3/8							5/16	13.4		
1 1/2	6 1/4	7/8	3/8	3/4	8	8 x 3/4 x 8 11 lbs.	2 7/16	5/8	21.25	8
1 1/2							9/16	18.75		
1 3/8							7/16	16.25		
1 1/4							3/8	13.75		
1 1/4							5/16	11.50		

All rivets in standard connections are 3/4" diameter. Weights of standard connections include the shop rivets but no field rivets.

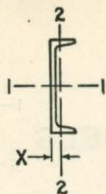

PROPERTIES OF STANDARD CHANNELS

Section Number	Depth of Channel, Inches	Weight per Foot, Pounds	Area of Section, Sq. Inches	Width of Flange, Inches		Thickness of Web, Inches	
136	7	19.75	5.81	2.51	2 1/2	.63	5/8
		17.25	5.07	2.40	2 13/32	.52	17/32
		14.75	4.34	2.30	2 5/16	.42	13/32
		12.25	3.60	2.19	2 3/16	.31	5/16
		9.80	2.88	2.09	2 3/32	.21	7/32
144	6	15.50	4.56	2.28	2 9/32	.56	9/16
		13.00	3.82	2.16	2 5/32	.44	7/16
		10.50	3.09	2.03	2 1/32	.31	5/16
		8.20	2.41	1.92	1 29/32	.20	3/16

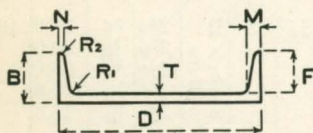

DIMENSIONS OF MINIMUM CHANNEL SECTIONS

Section Number	Depth D	Weight	B	T	F	M	N	R ₁	R ₂
136	7	9.8	2.09	.21	1.88	.523	.21	.31	.13
144	6	8.2	1.92	.20	1.72	.487	.20	.30	.12

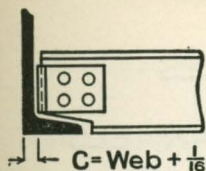

PROPERTIES
OF
STANDARD CHANNELS

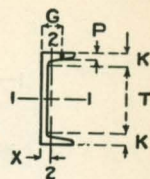

Resisting Moment in Foot Pounds at 18,000 lbs. per Sq. Inch	AXIS 1-1			AXIS 2-2				Depth of Channel, Inches
	Moment of Inertia	Radius of Gyration	Section Modulus	Moment of Inertia	Radius of Gyration	Section Modulus	Location of Center of Gravity X	
14,250	33.2	2.39	9.5	1.8	.56	.96	.58	7
12,900	30.2	2.44	8.6	1.6	.56	.87	.55	
11,700	27.2	2.50	7.8	1.4	.57	.79	.53	
10,350	24.2	2.59	6.9	1.2	.57	.71	.53	
9,150	21.2	2.71	6.1	1.0	.58	.63	.55	
9,750	19.5	2.07	6.5	1.3	.53	.73	.54	6
8,700	17.3	2.13	5.8	1.1	.53	.65	.52	
7,500	15.1	2.21	5.0	.87	.53	.57	.50	
6,600	13.1	2.33	4.4	.70	.54	.50	.52	

CHANNEL CONNECTIONS

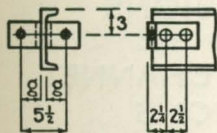

7" and 6"

2 L^s 6 × 4 × 3/8 × 2 1/2
6 lbs.

Gauge G, Inches	Tangent T, Inches	Distance K, Inches	Grip P, Inches	Max. Rivet in Flange	Wall Bearing	Wall Plates	Gauge g, Inches	Dist. C, Inches	Weight per Foot	Depth
1 1/2	5 1/2	3/4	3/8	5/8	8	8 × 5/8 × 8	2 1/16	1 1/16	19.75	7
1 1/2			3/8			11 lbs.	2 1/2	9/16	17.25	
1 1/4			3/8				2 9/16	1/2	14.75	
1 1/4			3/8				2 9/16	3/8	12.25	
1 1/4			3/8				2 5/8	1/4	9.80	
1 3/8	4 1/2	3/4	3/8	5/8	6	6 × 1/2 × 6	2 1/2	5/8	15.50	6
1 3/8			3/8			5 lbs.	2 9/16	1/2	13.00	
1 1/8			3/8				2 9/16	3/8	10.50	
1 1/8			3/8				2 5/8	1/4	8.20	

All rivets in standard connections are 3/4" diameter. Weights of standard connections include the shop rivets, but no field rivets.

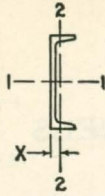

PROPERTIES OF STANDARD CHANNELS

Section Number	Depth of Channel, Inches	Weight per Foot, Pounds	Area of Section, Sq. Inches	Width of Flange, Inches		Thickness of Web, Inches	
120	5	11.50	3.38	2.03	$2\frac{1}{32}$.47	$\frac{15}{32}$
		9.00	2.65	1.89	$1\frac{7}{8}$.33	$\frac{11}{32}$
		6.70	1.97	1.75	$1\frac{3}{4}$.19	$\frac{3}{16}$
118	4	7.25	2.13	1.72	$1\frac{23}{32}$.32	$\frac{5}{16}$
		6.25	1.84	1.64	$1\frac{21}{32}$.24	$\frac{1}{4}$
		5.40	1.59	1.58	$1\frac{19}{32}$.18	$\frac{3}{16}$
116	3	6.00	1.76	1.60	$1\frac{19}{32}$.36	$\frac{3}{8}$
		5.00	1.47	1.50	$1\frac{1}{2}$.26	$\frac{1}{4}$
		4.10	1.21	1.41	$1\frac{13}{32}$.17	$\frac{5}{32}$

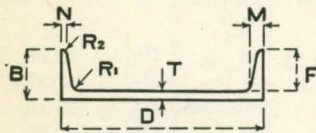

DIMENSIONS OF MINIMUM CHANNEL SECTIONS

Section Number	Depth D	Weight	B	T	F	M	N	R ₁	R ₂
120	5	6.7	1.75	.19	1.56	.450	.19	.29	.11
118	4	5.4	1.58	.18	1.40	.413	.18	.28	.11
116	3	4.1	1.41	.17	1.24	.377	.17	.27	.10

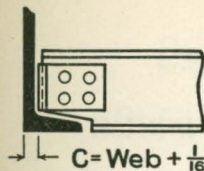

PROPERTIES OF STANDARD CHANNELS

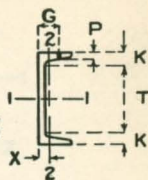

Resisting Moment in Foot Pounds at 18,000 lbs. per Sq. Inch	AXIS 1-1			AXIS 2-2				Depth of Channel, Inches
	Moment of Inertia	Radius of Gyration	Section Modulus	Moment of Inertia	Radius of Gyration	Section Modulus	Location of Center of Gravity X	
6,300	10.4	1.75	4.2	.82	.49	.54	.51	5
5,400	8.9	1.83	3.6	.64	.49	.46	.48	
4,500	7.4	1.95	3.0	.48	.49	.38	.49	
3,450	4.6	1.46	2.3	.44	.45	.35	.46	4
3,150	4.2	1.51	2.1	.38	.45	.32	.46	
2,850	3.8	1.56	1.9	.32	.45	.29	.46	
2,100	2.1	1.08	1.4	.31	.42	.27	.46	
1,800	1.8	1.12	1.2	.25	.41	.24	.44	3
1,650	1.7	1.17	1.1	.20	.41	.21	.44	

CHANNEL CONNECTIONS

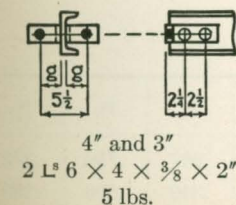
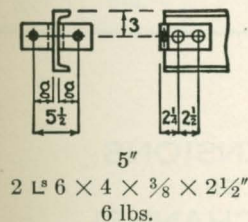

Gauge G, Inches	Tangent T, Inches	Distance K, Inches	Grip P, Inches	Max. Rivet in Flange	Wall Bearing	Wall Plates	Gauge g, Inches	Dist. C, Inches	Weight per Foot	Depth
1 1/4	3 3/4	5/8	5/16	1/2	6	6 x 1/2 x 6	2 1/2	3/16	11.50	5
1 1/8						6 x 1/2 x 6	2 9/16	3/8	9.00	
1						5 lbs.	2 5/8	1/4	6.70	
1	2 3/4	5/8	5/16	1/2	6	6 x 1/2 x 6	2 9/16	3/8	7.25	4
1						5 lbs.	2 5/8	5/16	6.25	
1 5/16						5 lbs.	2 11/16	1/4	5.40	
1 5/16	1 3/4	5/8	1/4	3/8	6	6 x 1/2 x 6	2 9/16	7/16	6.00	3
1 5/16						5 lbs.	2 5/8	5/16	5.00	
1 5/16						5 lbs.	2 11/16	1/4	4.10	

All rivets in standard connections are 3/4" diameter. Weights of standard connections include the shop rivets but no field rivets.

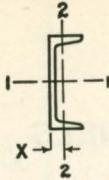

PROPERTIES OF SPECIAL CHANNELS

Section Number	Depth of Channel, Inches	Weight per Foot, Pounds	Area of Section, Sq. Inches	Width of Flange, Inches		Thickness of Web, Inches	
124	15	75.0	22.06	4.491	4½	1.116	1⅛
		69.1	20.32	4.375	4⅜	1.000	1
		65.9	19.38	4.312	4⅝	.937	15/16
		62.8	18.47	4.251	4¼	.876	7/8
		59.6	17.53	4.188	4⅜	.813	13/16
		56.4	16.59	4.126	4⅛	.751	3/4
		53.2	15.65	4.063	4⅜	.688	11/16
		50.0	14.71	4.000	4	.625	5/8
246	13	55.0	16.18	4.525	4 17/32	.900	29/32
		50.0	14.71	4.412	4 13/32	.787	25/32
		45.0	13.24	4.299	4 5/16	.674	11/16
		40.0	11.76	4.186	4 3/16	.561	9/16
		37.0	10.88	4.118	4 1/8	.493	1/2
		35.0	10.29	4.072	4 1/16	.447	7/16
		31.8	9.35	4.000	4	.375	3/8

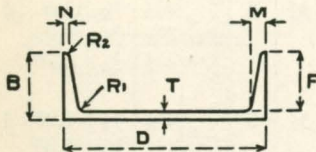

DIMENSIONS OF BASE CHANNEL SECTIONS

Section Number	Depth D	Weight	B	T	F	M	N	R ₁	R ₂
124	15	50.0	4.00	.625	3.375	.906	.687	.750	.375
246	13	31.8	4.00	.375	3.625	.880	.340	.500	.250

**PROPERTIES
OF
SPECIAL CHANNELS**

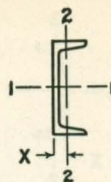

Resisting Moment in Foot Pounds at 18,000 lbs. per Sq. Inch	AXIS 1-1			AXIS 2-2				Depth of Channel, Inches
	Moment of Inertia	Radius of Gyration	Section Modulus	Moment of Inertia	Radius of Gyration	Section Modulus	Location of Center of Gravity	
	I	r	S	I	r	S	x	
116,800	584.0	5.14	77.9	25.9	1.08	7.6	1.08	15
110,250	551.5	5.21	73.5	23.9	1.09	7.2	1.06	
106,800	533.9	5.25	71.2	22.9	1.09	7.0	1.04	
103,350	516.8	5.29	68.9	21.9	1.09	6.8	1.03	
99,900	499.1	5.34	66.6	20.9	1.09	6.6	1.02	
96,300	481.5	5.39	64.2	19.9	1.10	6.4	1.02	
92,700	463.8	5.44	61.8	19.0	1.10	6.2	1.01	
89,250	446.2	5.51	59.5	18.0	1.11	6.0	1.01	
77,100	334.4	4.55	51.4	18.1	1.06	5.1	1.00	13
72,450	313.7	4.62	48.3	16.7	1.06	4.9	.98	
67,650	292.9	4.70	45.1	15.3	1.07	4.6	.97	
62,850	272.2	4.81	41.9	13.9	1.09	4.3	.97	
60,000	259.8	4.89	40.0	13.1	1.10	4.2	.98	
58,050	251.5	4.94	38.7	12.5	1.10	4.0	.99	
55,050	238.3	5.05	36.7	11.5	1.11	3.9	1.01	

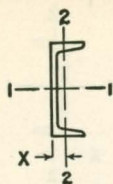

PROPERTIES OF SPECIAL CHANNELS

Section Number	Depth of Channel, Inches	Weight per Foot, Pounds	Area of Section, Sq. Inches	Width of Flange, Inches		Thickness of Web, Inches	
181	12	49.4	14.53	4.000	4	.875	$\frac{7}{8}$
		46.9	13.79	3.939	$3\frac{15}{16}$.814	$1\frac{3}{16}$
		44.3	13.03	3.875	$3\frac{7}{8}$.750	$\frac{3}{4}$
		41.8	12.29	3.814	$3\frac{13}{16}$.689	$1\frac{1}{16}$
		39.2	11.53	3.750	$3\frac{3}{4}$.625	$\frac{5}{8}$
		36.7	10.79	3.689	$3\frac{11}{16}$.564	$\frac{9}{16}$
		34.1	10.03	3.625	$3\frac{5}{8}$.500	$\frac{1}{2}$
		31.6	9.29	3.564	$3\frac{9}{16}$.439	$\frac{7}{16}$
		29.0	8.53	3.500	$3\frac{1}{2}$.375	$\frac{3}{8}$
276	12	41.1	12.09	3.701	$3\frac{11}{16}$.701	$1\frac{1}{16}$
		37.0	10.88	3.601	$3\frac{19}{32}$.601	$1\frac{9}{32}$
		32.9	9.68	3.500	$3\frac{1}{2}$.500	$\frac{1}{2}$
		30.9	9.09	3.451	$3\frac{7}{16}$.451	$\frac{7}{16}$

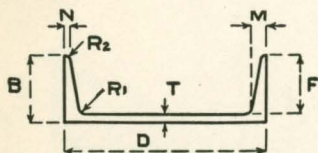

DIMENSIONS OF BASE CHANNEL SECTIONS

Section Number	Depth D	Weight	B	T	F	M	N	R ₁	R ₂
181	12	29.0	3.50	.375	3.125	.810	.437	.625	.250
276	12	32.9	3.50	.500	3.000	.652	.548	.600	.425

PROPERTIES OF SPECIAL CHANNELS

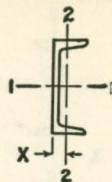

Resisting Moment in Foot Pounds at 18,000 lbs. per Sq. Inch	AXIS 1-1			AXIS 2-2				Depth of Channel, Inches
	Moment of Inertia	Radius of Gyration	Section Modulus	Moment of Inertia	Radius of Gyration	Section Modulus	Location of Center of Gravity	
	I	r	S	I	r	S	x	
63,350	253.4	4.18	42.2	13.4	.96	4.4	.94	12
61,150	244.6	4.21	40.8	12.8	.96	4.2	.92	
58,850	235.4	4.25	39.2	12.1	.97	4.1	.91	
56,650	226.6	4.29	37.8	11.5	.97	4.0	.91	
54,350	217.4	4.34	36.2	10.9	.97	3.8	.90	
52,150	208.6	4.40	34.8	10.3	.98	3.7	.90	
49,850	199.4	4.46	33.2	9.7	.98	3.6	.90	
47,650	190.6	4.53	31.8	9.1	.99	3.4	.91	
45,350	181.4	4.61	30.2	8.4	.99	3.3	.93	
54,750	218.9	4.26	36.5	11.3	.97	4.0	.89	12
51,150	204.4	4.33	34.1	10.3	.97	3.8	.89	
47,550	190.0	4.43	31.7	9.4	.98	3.6	.89	
45,750	182.9	4.49	30.5	8.9	.99	3.5	.90	

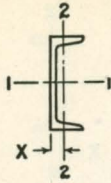

PROPERTIES OF SPECIAL CHANNELS

Section Number	Depth of Channel, Inches	Weight per Foot, Pounds	Area of Section, Sq. Inches	Width of Flange, Inches		Thickness of Web, Inches	
275	10	35.1	10.32	3.700	$3\frac{1}{16}$.675	$\frac{11}{16}$
		31.7	9.32	3.600	$3\frac{19}{32}$.575	$\frac{9}{16}$
		28.3	8.32	3.500	$3\frac{1}{2}$.475	$\frac{15}{32}$
		26.6	7.82	3.450	$3\frac{7}{16}$.425	$\frac{7}{16}$
		24.9	7.32	3.400	$3\frac{13}{32}$.375	$\frac{3}{8}$
283	10	25.3	7.44	3.550	$3\frac{9}{16}$.425	$\frac{7}{16}$
		23.6	6.94	3.500	$3\frac{1}{2}$.375	$\frac{3}{8}$
		21.9	6.44	3.450	$3\frac{7}{16}$.325	$\frac{5}{16}$
250	10	21.8	6.41	3.375	$3\frac{3}{8}$.375	$\frac{3}{8}$
274	9	31.6	9.29	3.703	$3\frac{1}{16}$.653	$\frac{21}{32}$
		28.5	8.38	3.601	$3\frac{19}{32}$.551	$\frac{9}{16}$
		25.4	7.47	3.500	$3\frac{1}{2}$.450	$\frac{7}{16}$
		23.9	7.03	3.451	$3\frac{7}{16}$.401	$\frac{13}{32}$

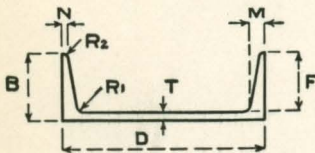

DIMENSIONS OF BASE CHANNEL SECTIONS

Section Number	Depth D	Weight	B	T	F	M	N	R ₁	R ₂
275	10	28.3	3.500	.475	3.025	.628	.522	.575	.400
283	10	23.6	3.500	.375	3.125	.555	.445	.500	.350
250	10	21.8	3.375	.375	3.000	.489	.406	.400	.300
274	9	25.4	3.500	.450	3.050	.603	.497	.550	.375

PROPERTIES OF SPECIAL CHANNELS

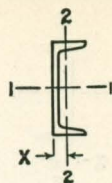

Resisting Moment in Foot Pounds at 18,000 lbs. per Sq. Inch	AXIS 1-1			AXIS 2-2				Depth of Channel, Inches
	Moment of Inertia	Radius of Gyration	Section Modulus	Moment of Inertia	Radius of Gyration	Section Modulus	Location of Center of Gravity	
	I	r	S	I	r	S	x	
40,350	134.4	3.61	26.9	10.4	1.00	3.8	.95	10
37,800	126.0	3.68	25.2	9.5	1.01	3.6	.95	
35,250	117.7	3.76	23.5	8.6	1.01	3.4	.96	
34,050	113.5	3.81	22.7	8.1	1.02	3.3	.97	
32,850	109.4	3.87	21.9	7.6	1.02	3.2	.98	10
31,950	106.5	3.78	21.3	7.9	1.03	3.0	.94	
30,600	102.4	3.84	20.4	7.5	1.04	2.9	.96	
29,400	98.2	3.90	19.6	7.0	1.04	2.8	.98	
27,450	91.6	3.78	18.3	6.2	.99	2.5	.87	10
33,300	100.0	3.28	22.2	9.7	1.02	3.6	.98	9
31,350	93.9	3.35	20.9	8.9	1.03	3.4	.98	
29,250	87.7	3.43	19.5	8.0	1.03	3.2	1.00	
28,200	84.8	3.47	18.8	7.5	1.03	3.1	1.01	

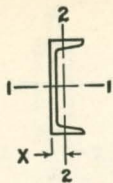

PROPERTIES OF SPECIAL CHANNELS

Section Number	Depth of Channel, Inches	Weight per Foot, Pounds	Area of Section, Sq. Inches	Width of Flange, Inches		Thickness of Web, Inches	
273	8	28.2	8.29	3.700	$3\frac{11}{16}$.625	$\frac{5}{8}$
		25.5	7.50	3.600	$3\frac{9}{32}$.525	$\frac{17}{32}$
		22.8	6.71	3.500	$3\frac{1}{2}$.425	$\frac{7}{16}$
		21.4	6.29	3.450	$3\frac{7}{16}$.375	$\frac{3}{8}$
284	8	25.5	7.50	3.228	$3\frac{7}{32}$.603	$\frac{19}{32}$
		22.7	6.68	3.125	$3\frac{1}{8}$.500	$\frac{1}{2}$
		20.0	5.88	3.026	$3\frac{3}{32}$.401	$\frac{13}{32}$
		19.3	5.68	3.000	3	.375	$\frac{3}{8}$
272	7	25.0	7.35	3.698	$3\frac{11}{16}$.598	$\frac{19}{32}$
		22.7	6.68	3.601	$3\frac{9}{32}$.501	$\frac{1}{2}$
		20.3	5.97	3.500	$3\frac{1}{2}$.400	$\frac{13}{32}$
		19.1	5.62	3.450	$3\frac{7}{16}$.350	$\frac{11}{32}$
285	7	20.0	5.88	3.101	$3\frac{3}{32}$.476	$\frac{15}{32}$
		17.6	5.18	3.000	3	.375	$\frac{3}{8}$
		16.4	4.82	2.950	$2\frac{15}{16}$.325	$\frac{5}{16}$
271	6	18.0	5.29	3.632	$3\frac{5}{8}$.472	$\frac{15}{32}$
		15.3	4.50	3.500	$3\frac{1}{2}$.340	$\frac{11}{32}$

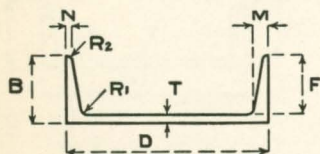

DIMENSIONS OF BASE CHANNEL SECTIONS

Section Number	Depth D	Weight	B	T	F	M	N	R ₁	R ₂
273	8	22.8	3.50	.425	3.075	.579	.471	.525	.375
284	8	19.3	3.00	.375	2.625	.546	.454	.500	.350
272	7	20.3	3.50	.400	3.100	.554	.446	.500	.350
285	7	17.6	3.00	.375	2.625	.521	.429	.475	.325
271	6	15.3	3.50	.340	3.160	.440	.330	.385	.300

PROPERTIES
OF
SPECIAL CHANNELS

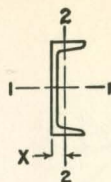

Resisting Moment in Foot-Pounds at 18,000 lbs. per Sq. Inch	AXIS 1-1			AXIS 2-2				Depth of Channel, Inches	
	Moment of Inertia	Radius of Gyration	Section Modulus	Moment of Inertia	Radius of Gyration	Section Modulus	Location of Center of Gravity		
	I	r	S	I	r	S	x		
27,000	72.2	2.95	18.0	9.0	1.04	3.4	1.02	8	
25,500	67.9	3.01	17.0	8.2	1.05	3.2	1.02		
23,850	63.7	3.08	15.9	7.4	1.05	3.0	1.04		
23,100	61.5	3.13	15.4	6.9	1.05	2.9	1.05		
23,550	63.0	2.90	15.7	5.9	.88	2.5	.86	8	
21,900	58.6	2.96	14.6	5.3	.89	2.3	.85		
20,400	54.3	3.04	13.6	4.7	.89	2.2	.86		
19,950	53.2	3.06	13.3	4.5	.89	2.1	.87		
19,650	52.3	3.08	13.1	4.4	.89	2.1	.87		
21,450	50.2	2.61	14.3	8.3	1.06	3.2	1.06		7
20,250	47.4	2.66	13.5	7.6	1.06	3.0	1.07		
19,050	44.5	2.73	12.7	6.7	1.06	2.8	1.09		
18,450	43.1	2.77	12.3	6.3	1.06	2.7	1.11		
17,250	40.4	2.62	11.5	4.7	.90	2.1	.88	7	
16,050	37.5	2.69	10.7	4.2	.90	2.0	.90		
15,450	36.1	2.74	10.3	3.9	.90	1.9	.91		
13,950	27.8	2.30	9.3	6.0	1.06	2.3	1.04	6	
12,750	25.4	2.38	8.5	5.1	1.07	2.1	1.08		

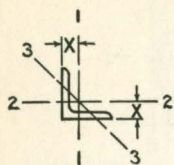

Radius of fillet
 $\frac{5}{8}$ " for 8 \times 8
 $\frac{3}{8}$ " for 6 \times 6

PROPERTIES OF ANGLES EQUAL LEGS

Section Number	Size, Inches	Thickness, Inches	Weight per Foot, Pounds	Area of Section, Sq. Inches	AXIS 1-1 AND AXIS 2-2				AXIS 3-3		
					Location of Center of Gravity	Moment of Inertia	Radius of Gyration	Section Modulus	Radius of Gyration		
					x	I	r	S	r min.		
240	8 \times 8	$1\frac{1}{4}$	63.5	19.12	2.45	106.5	2.40	19.2	1.55		
		$1\frac{1}{8}$	56.9	16.73	2.41	98.0	2.42	17.5	1.55		
		$1\frac{1}{16}$	54.0	15.88	2.39	93.5	2.43	16.7	1.56		
		1	51.0	15.00	2.37	89.0	2.44	15.8	1.56		
		$1\frac{5}{16}$	48.1	14.15	2.34	84.3	2.44	14.9	1.56		
		$\frac{7}{8}$	45.0	13.23	2.32	79.6	2.45	14.0	1.56		
		$1\frac{3}{16}$	42.0	12.35	2.30	74.7	2.46	13.1	1.57		
		$\frac{3}{4}$	38.9	11.44	2.28	69.7	2.47	12.2	1.57		
		$1\frac{1}{16}$	35.8	10.53	2.25	64.6	2.48	11.2	1.58		
		$\frac{5}{8}$	32.7	9.62	2.23	59.4	2.49	10.3	1.58		
		$\frac{9}{16}$	29.6	8.71	2.21	54.1	2.50	9.3	1.58		
		$\frac{1}{2}$	26.4	7.76	2.19	48.6	2.51	8.4	1.58		
		127	6 \times 6	$1\frac{1}{4}$	46.9	13.79	1.95	41.9	1.77	10.3	1.16
				$1\frac{1}{8}$	42.2	12.41	1.91	38.8	1.78	9.5	1.16
$1\frac{1}{16}$	39.5			11.71	1.89	37.1	1.79	9.0	1.16		
1	37.4			11.00	1.86	35.5	1.80	8.6	1.16		
$1\frac{5}{16}$	35.3			10.38	1.84	33.7	1.80	8.1	1.16		
$\frac{7}{8}$	33.1			9.73	1.82	31.9	1.81	7.6	1.17		
$1\frac{3}{16}$	31.0			9.12	1.80	30.1	1.82	7.2	1.17		
$\frac{3}{4}$	28.7			8.44	1.78	28.2	1.83	6.7	1.17		
$1\frac{1}{16}$	26.5			7.79	1.75	26.2	1.83	6.2	1.17		
$\frac{5}{8}$	24.2			7.12	1.73	24.2	1.84	5.7	1.17		
$\frac{9}{16}$	21.9			6.44	1.71	22.1	1.85	5.1	1.18		
$\frac{1}{2}$	19.6			5.76	1.68	19.9	1.86	4.6	1.18		
$\frac{7}{16}$	17.2			5.06	1.66	17.7	1.87	4.1	1.19		
$\frac{3}{8}$	14.9			4.38	1.64	15.4	1.88	3.5	1.19		
$\frac{5}{16}$	12.5	3.68	1.62	13.0	1.89	3.0	1.20				

PROPERTIES OF ANGLES EQUAL LEGS

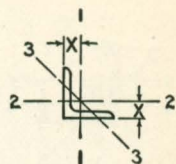

Radius of Fillet, $\frac{3}{8}$ "

Section Number	Size, Inches	Thickness, Inches	Weight per Foot, Pounds	Area of Section, Sq. Inches	AXIS 1-1 AND AXIS 2-2				AXIS 3-3
					Location of Center of Gravity	Moment of Inertia	Radius of Gyration	Section Modulus	Radius of Gyration
					x	I	r	S	r min.
126	5×5	1	30.6	9.00	1.61	19.6	1.48	5.8	.96
		$\frac{15}{16}$	28.9	8.50	1.59	18.7	1.48	5.5	.96
		$\frac{7}{8}$	27.2	8.00	1.57	17.8	1.49	5.2	.96
		$\frac{13}{16}$	25.4	7.47	1.55	16.8	1.50	4.9	.97
		$\frac{3}{4}$	23.6	6.94	1.52	15.7	1.50	4.5	.97
		$\frac{11}{16}$	21.8	6.41	1.50	14.7	1.51	4.2	.97
		$\frac{5}{8}$	20.0	5.88	1.48	13.6	1.52	3.9	.97
		$\frac{9}{16}$	18.1	5.32	1.46	12.4	1.53	3.5	.98
		$\frac{1}{2}$	16.2	4.76	1.43	11.3	1.54	3.2	.98
		$\frac{7}{16}$	14.3	4.21	1.41	10.0	1.55	2.8	.98
		$\frac{3}{8}$	12.3	3.62	1.39	8.7	1.56	2.4	.99
		$\frac{5}{16}$	10.1	2.97	1.37	7.4	1.57	2.0	.99
		14	4×4	1	25.4	7.47	1.36	9.4	1.12
$\frac{15}{16}$	23.9			7.03	1.34	9.0	1.13	3.4	.76
$\frac{7}{8}$	22.3			6.56	1.31	8.6	1.15	3.2	.76
$\frac{13}{16}$	19.9			5.85	1.29	8.1	1.18	3.0	.77
$\frac{3}{4}$	18.5			5.44	1.27	7.7	1.19	2.8	.77
$\frac{11}{16}$	17.1			5.03	1.25	7.2	1.19	2.6	.77
$\frac{5}{8}$	15.7			4.62	1.23	6.7	1.20	2.4	.77
$\frac{9}{16}$	14.3			4.21	1.21	6.1	1.21	2.2	.78
$\frac{1}{2}$	12.8			3.76	1.18	5.6	1.22	2.0	.78
$\frac{7}{16}$	11.3			3.32	1.16	5.0	1.23	1.8	.78
$\frac{3}{8}$	9.8			2.88	1.14	4.4	1.23	1.5	.79
$\frac{5}{16}$	8.2			2.41	1.12	3.7	1.24	1.3	.79
$\frac{1}{4}$	6.6			1.94	1.09	3.0	1.25	1.0	.79

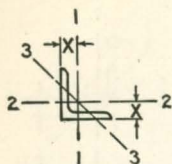
Radius of Fillet, $\frac{3}{8}$ "

PROPERTIES OF ANGLES EQUAL LEGS

Section Number	Size, Inches	Thickness, Inches	Weight per Foot, Pounds	Area of Section, Sq. Inches	AXIS 1-1 AND AXIS 2-2				AXIS 3-3
					Location of Center of Gravity	Moment of Inertia	Radius of Gyration	Section Modulus	Radius of Gyration
					x	I	r	S	r min.
15	$3\frac{1}{2} \times 3\frac{1}{2}$	$\frac{7}{8}$	18.3	5.38	1.19	5.5	1.01	2.4	.66
		$\frac{13}{16}$	17.1	5.03	1.17	5.3	1.02	2.3	.67
		$\frac{3}{4}$	16.0	4.71	1.15	5.0	1.03	2.1	.67
		$\frac{11}{16}$	14.8	4.35	1.12	4.7	1.04	2.0	.67
		$\frac{5}{8}$	13.6	4.00	1.10	4.3	1.04	1.8	.68
		$\frac{9}{16}$	12.4	3.65	1.08	4.0	1.05	1.6	.68
		$\frac{1}{2}$	11.1	3.26	1.06	3.6	1.06	1.5	.68
		$\frac{7}{16}$	9.8	2.88	1.04	3.3	1.07	1.3	.68
		$\frac{3}{8}$	8.5	2.50	1.01	2.9	1.07	1.2	.69
		$\frac{5}{16}$	7.2	2.12	.99	2.5	1.08	.98	.69
		$\frac{1}{4}$	5.8	1.71	.97	2.0	1.09	.79	.69
$\frac{3}{16}$	4.4	1.29	.94	1.6	1.10	.60	.69		
16	3x3	$\frac{7}{8}$	16.5	4.85	1.06	3.3	.86	1.7	.57
		$\frac{13}{16}$	15.5	4.56	1.04	3.2	.86	1.6	.57
		$\frac{3}{4}$	14.4	4.24	1.02	3.0	.87	1.5	.57
		$\frac{11}{16}$	13.0	3.82	1.00	2.8	.87	1.4	.57
		$\frac{5}{8}$	11.5	3.38	.98	2.6	.88	1.3	.57
		$\frac{9}{16}$	10.4	3.06	.95	2.4	.89	1.2	.58
		$\frac{1}{2}$	9.4	2.76	.93	2.2	.90	1.1	.58
		$\frac{7}{16}$	8.3	2.44	.91	2.0	.91	.95	.58
		$\frac{3}{8}$	7.2	2.12	.89	1.8	.91	.83	.58
		$\frac{5}{16}$	6.1	1.79	.87	1.5	.92	.71	.59
		$\frac{1}{4}$	4.9	1.44	.84	1.2	.93	.58	.59
$\frac{3}{16}$	3.7	1.09	.82	.96	.94	.44	.60		

PROPERTIES OF ANGLES EQUAL LEGS

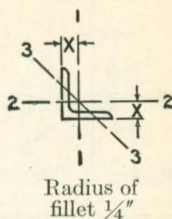

Section Number	Size, Inches	Thickness, Inches	Weight per Foot, Pounds	Area of Section, Sq. Inches	AXIS 1-1 AND AXIS 2-2				AXIS 3-3
					Location of Center of Gravity	Moment of Inertia	Radius of Gyration	Section Modulus	Radius of Gyration
									r min.
x	I	r	S	r min.					
17	$2\frac{1}{2} \times 2\frac{1}{2}$	$\frac{5}{8}$	9.6	2.82	.85	1.4	.72	.87	.47
		$\frac{9}{16}$	8.6	2.53	.83	1.3	.73	.80	.47
		$\frac{1}{2}$	7.7	2.26	.81	1.2	.74	.73	.47
		$\frac{7}{16}$	6.8	2.00	.78	1.1	.75	.65	.48
		$\frac{3}{8}$	5.9	1.74	.76	.98	.75	.57	.48
		$\frac{5}{16}$	5.0	1.47	.74	.85	.76	.48	.49
		$\frac{1}{4}$	4.1	1.21	.72	.70	.77	.39	.49
$\frac{3}{16}$	3.07	.90	.69	.55	.78	.30	.49		
18	2×2	$\frac{7}{16}$	5.3	1.56	.66	.54	.59	.40	.39
		$\frac{3}{8}$	4.7	1.38	.64	.48	.59	.35	.39
		$\frac{5}{16}$	3.92	1.15	.61	.42	.60	.30	.39
		$\frac{1}{4}$	3.19	.94	.59	.35	.61	.25	.39
		$\frac{3}{16}$	2.44	.72	.57	.28	.62	.19	.40

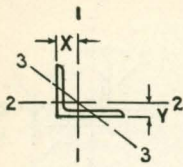
Radius of Fillet, $\frac{1}{2}$ "

PROPERTIES OF ANGLES UNEQUAL LEGS

Section Number	Size, Inches	Thickness, Inches	Weight per Foot, Pounds	Area of Section, Sq. Inches	AXIS 1-1			
					Location of Center of Gravity	Moment of Inertia	Radius of Gyration	Section Modulus
					x	I	r	S
197	8×6	$\frac{1}{8}$	50.5	14.85	2.70	88.9	2.45	16.8
		$\frac{1}{16}$	47.5	13.97	2.68	84.9	2.47	16.0
		1	44.2	13.00	2.65	80.8	2.49	15.1
		$\frac{15}{16}$	41.7	12.26	2.63	76.6	2.50	14.3
		$\frac{7}{8}$	39.1	11.50	2.61	72.3	2.51	13.4
		$\frac{13}{16}$	36.5	10.74	2.59	67.9	2.52	12.5
		$\frac{3}{4}$	33.8	9.94	2.56	63.4	2.53	11.7
		$\frac{11}{16}$	31.2	9.18	2.54	58.8	2.54	10.8
		$\frac{5}{8}$	28.5	8.38	2.52	54.1	2.54	9.9
		$\frac{9}{16}$	25.7	7.56	2.50	49.3	2.55	8.9
		$\frac{1}{2}$	23.0	6.76	2.47	44.3	2.56	8.0
		$\frac{7}{16}$	20.2	5.94	2.45	39.2	2.57	7.1
*182	8×3½	1	35.7	10.50	3.17	66.2	2.51	13.7
		$\frac{15}{16}$	33.7	9.91	3.14	62.9	2.52	12.9
		$\frac{7}{8}$	31.7	9.32	3.12	59.4	2.53	12.2
		$\frac{13}{16}$	29.6	8.71	3.10	55.9	2.54	11.4
		$\frac{3}{4}$	27.5	8.09	3.07	52.3	2.55	10.6
		$\frac{11}{16}$	25.3	7.44	3.05	48.5	2.56	9.8
		$\frac{5}{8}$	23.2	6.82	3.03	44.7	2.57	9.0
		$\frac{9}{16}$	21.0	6.18	3.00	40.8	2.57	8.2
		$\frac{1}{2}$	18.7	5.50	2.98	36.7	2.58	7.3
		$\frac{7}{16}$	16.5	4.85	2.95	32.5	2.59	6.4
		$\frac{3}{8}$	14.3	4.21	2.93	28.3	2.60	5.5

* Special

PROPERTIES OF ANGLES UNEQUAL LEGS

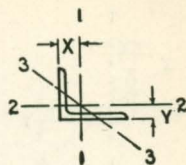

Radius of Fillet, $\frac{1}{2}$ "

AXIS 2-2				AXIS 3-3	Thickness, Inches	Size, Inches
Location of Center of Gravity	Moment of Inertia	Radius of Gyration	Section Modulus	Radius of Gyration		
y	I	r	S	r min.		
1.70	42.5	1.69	9.9	1.27	$1\frac{1}{8}$	8×6
1.68	40.7	1.71	9.4	1.27	$1\frac{1}{16}$	
1.65	38.8	1.73	8.9	1.28	1	
1.63	36.8	1.73	8.4	1.28	$\frac{15}{16}$	
1.61	34.9	1.74	7.9	1.28	$\frac{7}{8}$	
1.59	32.8	1.75	7.4	1.29	$\frac{13}{16}$	
1.56	30.7	1.76	6.9	1.29	$\frac{3}{4}$	
1.54	28.6	1.77	6.4	1.29	$1\frac{1}{16}$	
1.52	26.3	1.77	5.9	1.30	$\frac{5}{8}$	
1.50	24.0	1.78	5.3	1.30	$\frac{9}{16}$	
1.47	21.7	1.79	4.8	1.30	$\frac{1}{2}$	
1.45	19.3	1.80	4.2	1.30	$\frac{7}{16}$	
.92	7.8	.86	3.0	.73	1	
.89	7.4	.87	2.9	.73	$\frac{15}{16}$	
.87	7.1	.87	2.7	.73	$\frac{7}{8}$	
.85	6.7	.88	2.5	.73	$\frac{13}{16}$	
.82	6.3	.88	2.3	.73	$\frac{3}{4}$	
.80	5.9	.89	2.2	.73	$1\frac{1}{16}$	
.78	5.4	.90	2.0	.74	$\frac{5}{8}$	
.75	5.0	.90	1.8	.74	$\frac{9}{16}$	
.73	4.5	.91	1.6	.74	$\frac{1}{2}$	
.70	4.1	.92	1.5	.74	$\frac{7}{16}$	
.68	3.6	.92	1.3	.74	$\frac{3}{8}$	

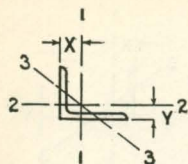
Radius of Fillet, $\frac{3}{8}$ "

PROPERTIES OF ANGLES UNEQUAL LEGS

Section Number	Size, Inches	Thickness, Inches	Weight per Foot, Pounds	Area of Section, Sq. Inches	AXIS 1-1			
					Location of Center of Gravity	Moment of Inertia	Radius of Gyration	Section Modulus
					x	I	r	S
*241	7×5	$\frac{13}{16}$	32.6	9.59	2.34	43.8	2.19	9.4
		$\frac{3}{4}$	30.0	8.82	2.32	40.9	2.20	8.7
		$\frac{11}{16}$	27.4	8.06	2.30	38.0	2.21	8.1
		$\frac{5}{8}$	24.8	7.29	2.28	35.0	2.22	7.4
		$\frac{9}{16}$	22.3	6.56	2.26	31.8	2.23	6.7
		$\frac{1}{2}$	19.8	5.82	2.23	28.6	2.24	6.0
		$\frac{7}{16}$	17.3	5.09	2.20	25.4	2.25	5.3
		$\frac{3}{8}$	14.7	4.32	2.18	22.2	2.26	4.6
*225	7×3½	1	32.3	9.50	2.71	45.4	2.19	10.6
		$\frac{15}{16}$	30.5	8.97	2.69	43.1	2.19	10.0
		$\frac{7}{8}$	28.7	8.44	2.66	40.8	2.20	9.4
		$\frac{13}{16}$	26.8	7.88	2.64	38.4	2.21	8.8
		$\frac{3}{4}$	24.9	7.32	2.62	36.0	2.22	8.2
		$\frac{11}{16}$	23.0	6.76	2.60	33.5	2.23	7.6
		$\frac{5}{8}$	21.0	6.18	2.57	30.9	2.24	7.0
		$\frac{9}{16}$	19.1	5.62	2.55	28.2	2.25	6.3
		$\frac{1}{2}$	17.0	5.00	2.53	25.4	2.25	5.7
		$\frac{7}{16}$	15.0	4.41	2.50	22.6	2.26	5.0
$\frac{3}{8}$	13.0	3.82	2.48	19.6	2.27	4.3		
91	6×4	1	30.6	9.00	2.17	30.8	1.85	8.0
		$\frac{15}{16}$	28.9	8.50	2.14	29.3	1.86	7.6
		$\frac{7}{8}$	27.2	8.00	2.12	27.7	1.86	7.2
		$\frac{13}{16}$	25.4	7.47	2.10	26.1	1.87	6.7
		$\frac{3}{4}$	23.6	6.94	2.08	24.5	1.88	6.2
		$\frac{11}{16}$	21.8	6.41	2.06	22.8	1.89	5.8
		$\frac{5}{8}$	20.0	5.88	2.03	21.1	1.90	5.3
		$\frac{9}{16}$	18.1	5.32	2.01	19.3	1.90	4.8
		$\frac{1}{2}$	16.2	4.76	1.99	17.4	1.91	4.3
		$\frac{7}{16}$	14.3	4.21	1.96	15.5	1.92	3.8
		$\frac{3}{8}$	12.3	3.62	1.94	13.5	1.93	3.3
		$\frac{5}{16}$	10.3	3.03	1.92	11.4	1.94	2.8

* Special

PROPERTIES OF ANGLES UNEQUAL LEGS

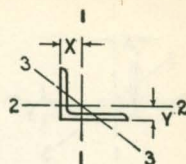

Radius of Fillet, $\frac{3}{8}$ "

AXIS 2-2				AXIS 3-3	Thickness, Inches	Size, Inches
Location of Center of Gravity	Moment of Inertia	Radius of Gyration	Section Modulus	Radius of Gyration		
y	I	r	S	r min.		
1.34	18.6	1.43	5.1	1.11	$\frac{13}{16}$	7×5
1.32	17.4	1.44	4.7	1.11	$\frac{3}{4}$	
1.29	16.2	1.45	4.4	1.12	$\frac{11}{16}$	
1.27	15.0	1.45	4.0	1.12	$\frac{5}{8}$	
1.25	13.7	1.46	3.7	1.12	$\frac{9}{16}$	
1.23	12.3	1.47	3.3	1.13	$\frac{1}{2}$	
1.20	11.0	1.48	2.9	1.13	$\frac{7}{16}$	
1.18	9.6	1.49	2.5	1.13	$\frac{3}{8}$	
.96	7.5	.89	3.0	.74	1	7×3½
.94	7.2	.89	2.8	.74	$\frac{15}{16}$	
.91	6.8	.90	2.6	.74	$\frac{7}{8}$	
.89	6.5	.91	2.5	.74	$\frac{13}{16}$	
.87	6.1	.91	2.3	.74	$\frac{3}{4}$	
.85	5.7	.92	2.1	.74	$\frac{11}{16}$	
.82	5.3	.93	2.0	.75	$\frac{5}{8}$	
.80	4.9	.93	1.8	.75	$\frac{9}{16}$	
.78	4.4	.94	1.6	.75	$\frac{1}{2}$	
.75	4.0	.95	1.4	.76	$\frac{7}{16}$	
.73	3.5	.96	1.3	.76	$\frac{3}{8}$	
1.17	10.8	1.09	3.8	.85	1	6×4
1.14	10.3	1.10	3.6	.85	$\frac{15}{16}$	
1.12	9.8	1.11	3.4	.86	$\frac{7}{8}$	
1.10	9.2	1.11	3.2	.86	$\frac{13}{16}$	
1.08	8.7	1.12	3.0	.86	$\frac{3}{4}$	
1.06	8.1	1.13	2.8	.86	$\frac{11}{16}$	
1.03	7.5	1.13	2.5	.86	$\frac{5}{8}$	
1.01	6.9	1.14	2.3	.87	$\frac{9}{16}$	
.99	6.3	1.15	2.1	.87	$\frac{1}{2}$	
.96	5.6	1.16	1.8	.87	$\frac{7}{16}$	
.94	4.9	1.17	1.6	.88	$\frac{3}{8}$	
.92	4.2	1.18	1.3	.88	$\frac{5}{16}$	

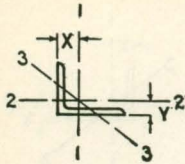
Radius of Fillet, $\frac{3}{8}$ "

PROPERTIES OF ANGLES UNEQUAL LEGS

Section Number	Size, Inches	Thickness, Inches	Weight per Foot, Pounds	Area of Section, Sq. Inches	AXIS 1-1			
					Location of Center of Gravity	Moment of Inertia	Radius of Gyration	Section Modulus
					x	I	r	S
92	6 × 3½	1	28.9	8.50	2.26	29.2	1.85	7.8
		15/16	27.3	8.03	2.24	27.8	1.86	7.4
		7/8	25.7	7.56	2.22	26.4	1.87	7.0
		13/16	24.0	7.06	2.20	24.9	1.88	6.6
		3/4	22.4	6.59	2.18	23.3	1.89	6.1
		11/16	20.6	6.06	2.15	21.7	1.89	5.6
		5/8	18.9	5.56	2.13	20.1	1.90	5.2
		9/16	17.1	5.03	2.11	18.4	1.91	4.7
		1/2	15.3	4.50	2.08	16.6	1.92	4.2
		7/16	13.5	3.97	2.06	14.8	1.93	3.7
		3/8	11.7	3.44	2.04	12.9	1.94	3.3
		5/16	9.8	2.88	2.01	10.9	1.95	2.7
		41	5 × 4	7/8	24.2	7.12	1.71	16.4
13/16	22.7			6.68	1.68	15.5	1.53	4.7
3/4	21.1			6.21	1.66	14.6	1.54	4.4
11/16	19.5			5.74	1.64	13.6	1.54	4.1
5/8	17.8			5.24	1.62	12.6	1.55	3.7
9/16	16.2			4.76	1.60	11.6	1.56	3.4
1/2	14.5			4.26	1.57	10.5	1.57	3.1
7/16	12.8			3.76	1.55	9.3	1.58	2.7
3/8	11.0			3.24	1.53	8.1	1.59	2.3
5/16	9.3			2.74	1.51	6.9	1.60	2.0
93	5 × 3½	7/8	22.7	6.68	1.79	15.7	1.53	4.9
		13/16	21.3	6.26	1.77	14.8	1.54	4.6
		3/4	19.8	5.82	1.75	13.9	1.55	4.3
		11/16	18.3	5.38	1.72	13.0	1.56	4.0
		5/8	16.8	4.94	1.70	12.0	1.56	3.7
		9/16	15.2	4.47	1.68	11.0	1.57	3.3
		1/2	13.6	4.00	1.66	10.0	1.58	3.0
		7/16	12.0	3.53	1.63	8.9	1.59	2.6
		3/8	10.4	3.06	1.61	7.8	1.60	2.3
		5/16	8.7	2.56	1.59	6.6	1.61	1.9
		1/4	7.0	2.06	1.57	5.4	1.62	1.6

PROPERTIES OF ANGLES UNEQUAL LEGS

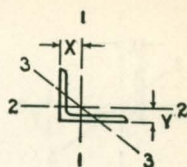

Radius of Fillet, $\frac{3}{8}$ "

AXIS 2-2				AXIS 3-3	Thickness, Inches	Size, Inches	
Location of Center of Gravity	Moment of Inertia	Radius of Gyration	Section Modulus	Radius of Gyration			
y	I	r	S	r min.			
1.01	7.2	.92	2.9	.74	1	6×3½	
.99	6.9	.93	2.7	.74	15/16		
.97	6.6	.93	2.6	.75	7/8		
.95	6.2	.94	2.4	.75	13/16		
.93	5.8	.94	2.3	.75	3/4		
.90	5.5	.95	2.1	.75	11/16		
.88	5.1	.96	1.9	.75	5/8		
.86	4.7	.96	1.8	.75	9/16		
.83	4.3	.97	1.6	.76	1/2		
.81	3.8	.98	1.4	.76	7/16		
.79	3.3	.99	1.2	.77	3/8		
.76	2.9	1.00	1.0	.77	5/16		
1.21	9.2	1.14	3.3	.84	7/8		5×4
1.18	8.7	1.15	3.1	.84	13/16		
1.16	8.2	1.15	2.9	.84	3/4		
1.14	7.7	1.16	2.7	.84	11/16		
1.12	7.1	1.17	2.5	.84	5/8		
1.10	6.6	1.18	2.3	.85	9/16		
1.07	6.0	1.18	2.0	.85	1/2		
1.05	5.3	1.19	1.8	.85	7/16		
1.03	4.7	1.20	1.6	.86	3/8		
1.01	4.0	1.21	1.3	.86	5/16		
1.04	6.2	.96	2.5	.75	7/8	5×3½	
1.02	5.9	.97	2.4	.75	13/16		
1.00	5.6	.98	2.2	.75	3/4		
.97	5.2	.98	2.1	.75	11/16		
.95	4.8	.99	1.9	.75	5/8		
.93	4.4	1.00	1.7	.75	9/16		
.91	4.0	1.01	1.6	.75	1/2		
.88	3.6	1.01	1.4	.76	7/16		
.86	3.2	1.02	1.2	.76	3/8		
.84	2.7	1.03	1.0	.76	5/16		
.82	2.2	1.03	.84	.76	1/4		

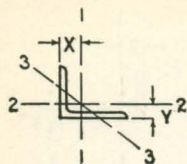

Radius of Fillet, $\frac{3}{8}$ "

PROPERTIES OF ANGLES UNEQUAL LEGS

Section Number	Size, Inches	Thickness, Inches	Weight per Foot, Pounds	Area of Section, Sq. Inches	AXIS 1-1			
					Location of Center of Gravity	Moment of Inertia	Radius of Gyration	Section Modulus
					x	I	r	S
42	5×3	$\frac{13}{16}$	19.9	5.85	1.86	14.0	1.55	4.5
		$\frac{3}{4}$	18.5	5.44	1.84	13.2	1.55	4.2
		$\frac{11}{16}$	17.1	5.03	1.82	12.3	1.56	3.9
		$\frac{5}{8}$	15.7	4.62	1.80	11.4	1.57	3.5
		$\frac{9}{16}$	14.3	4.21	1.77	10.4	1.58	3.2
		$\frac{1}{2}$	12.8	3.76	1.75	9.5	1.59	2.9
		$\frac{7}{16}$	11.3	3.32	1.73	8.4	1.60	2.6
		$\frac{3}{8}$	9.8	2.88	1.70	7.4	1.61	2.2
		$\frac{5}{16}$	8.2	2.41	1.68	6.3	1.61	1.9
	$\frac{1}{4}$	6.6	1.94	1.66	5.1	1.62	1.5	
*43	4½×3	$\frac{3}{4}$	17.3	5.09	1.63	9.7	1.39	3.4
		$\frac{11}{16}$	16.0	4.71	1.60	9.1	1.39	3.1
		$\frac{5}{8}$	14.7	4.32	1.58	8.4	1.40	2.9
		$\frac{9}{16}$	13.3	3.91	1.56	7.8	1.41	2.6
		$\frac{1}{2}$	11.9	3.50	1.54	7.0	1.42	2.4
		$\frac{7}{16}$	10.6	3.12	1.51	6.3	1.43	2.1
		$\frac{3}{8}$	9.1	2.68	1.49	5.5	1.44	1.8
		$\frac{5}{16}$	7.7	2.26	1.47	4.7	1.44	1.5
94	4×3½	$\frac{13}{16}$	18.5	5.44	1.36	7.8	1.19	2.9
		$\frac{3}{4}$	17.3	5.09	1.34	7.3	1.20	2.8
		$\frac{11}{16}$	16.0	4.71	1.32	6.9	1.21	2.6
		$\frac{5}{8}$	14.7	4.32	1.29	6.4	1.22	2.4
		$\frac{9}{16}$	13.3	3.91	1.27	5.9	1.23	2.1
		$\frac{1}{2}$	11.9	3.50	1.25	5.3	1.23	1.9
		$\frac{7}{16}$	10.6	3.12	1.23	4.8	1.24	1.7
		$\frac{3}{8}$	9.1	2.68	1.21	4.2	1.25	1.5
		$\frac{5}{16}$	7.7	2.26	1.18	3.6	1.26	1.3
	$\frac{1}{4}$	6.2	1.82	1.16	2.9	1.27	1.0	

* Special

PROPERTIES OF ANGLES UNEQUAL LEGS

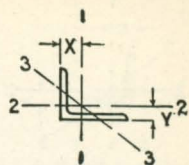
Radius of Fillet, $\frac{3}{8}$ "

AXIS 2-2				AXIS 3-3		Thickness, Inches	Size, Inches
Location of Center of Gravity	Moment of Inertia	Radius of Gyration	Section Modulus	Radius of Gyration			
y	I	r	S	r min.			
.86	3.7	.80	1.7	.64	$\frac{13}{16}$	5×3	
.84	3.5	.80	1.6	.64	$\frac{3}{4}$		
.82	3.3	.81	1.5	.64	$\frac{11}{16}$		
.80	3.1	.81	1.4	.64	$\frac{5}{8}$		
.77	2.8	.82	1.3	.65	$\frac{9}{16}$		
.75	2.6	.83	1.1	.65	$\frac{1}{2}$		
.73	2.3	.84	1.0	.65	$\frac{7}{16}$		
.70	2.0	.84	.89	.65	$\frac{3}{8}$		
.68	1.8	.85	.75	.66	$\frac{5}{16}$		
.66	1.4	.86	.61	.66	$\frac{1}{4}$		
.88	3.4	.82	1.6	.64	$\frac{3}{4}$	4½×3	
.85	3.2	.83	1.5	.64	$\frac{11}{16}$		
.83	3.0	.83	1.4	.64	$\frac{5}{8}$		
.81	2.8	.85	1.3	.64	$\frac{9}{16}$		
.79	2.5	.85	1.1	.65	$\frac{1}{2}$		
.76	2.3	.85	1.0	.65	$\frac{7}{16}$		
.74	2.0	.86	.88	.66	$\frac{3}{8}$		
.72	1.7	.87	.75	.66	$\frac{5}{16}$		
1.11	5.5	1.01	2.3	.72	$\frac{13}{16}$	4×3½	
1.09	5.2	1.01	2.1	.72	$\frac{3}{4}$		
1.07	4.9	1.02	2.0	.72	$\frac{11}{16}$		
1.04	4.5	1.03	1.8	.72	$\frac{5}{8}$		
1.02	4.2	1.03	1.7	.72	$\frac{9}{16}$		
1.00	3.8	1.04	1.5	.72	$\frac{1}{2}$		
.98	3.4	1.05	1.3	.72	$\frac{7}{16}$		
.96	3.0	1.06	1.2	.73	$\frac{3}{8}$		
.93	2.6	1.07	1.0	.73	$\frac{5}{16}$		
.91	2.1	1.08	.82	.73	$\frac{1}{4}$		

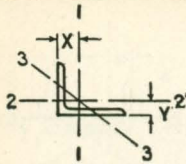

PROPERTIES OF ANGLES UNEQUAL LEGS

Radius of Fillet, $\frac{3}{8}$ " for
 4×3 " and $3\frac{1}{2} \times 3$ "
 $\frac{1}{4}$ " for $3\frac{1}{2} \times 2\frac{1}{2}$ "

Section Number	Size, Inches	Thickness, Inches	Weight per Foot, Pounds	Area of Section, Sq. Inches	AXIS 1-1					
					Location of Center of Gravity	Moment of Inertia	Radius of Gyration	Section Modulus		
					x	I	r	S		
44	4×3	$\frac{7}{8}$	19.1	5.62	1.46	7.7	1.21	3.0		
		$\frac{13}{16}$	17.1	5.03	1.44	7.3	1.21	2.9		
		$\frac{3}{4}$	16.0	4.71	1.42	6.9	1.22	2.7		
		$\frac{11}{16}$	14.8	4.35	1.39	6.5	1.22	2.5		
		$\frac{5}{8}$	13.6	4.00	1.37	6.0	1.23	2.3		
		$\frac{9}{16}$	12.4	3.65	1.35	5.6	1.24	2.1		
		$\frac{1}{2}$	11.1	3.26	1.33	5.0	1.25	1.9		
		$\frac{7}{16}$	9.8	2.88	1.30	4.5	1.25	1.7		
		$\frac{3}{8}$	8.5	2.50	1.28	4.0	1.26	1.5		
		$\frac{5}{16}$	7.2	2.12	1.26	3.4	1.27	1.2		
		$\frac{1}{4}$	5.8	1.71	1.24	2.8	1.28	1.0		
		$\frac{3}{16}$	4.5	1.32	1.21	2.1	1.28	.76		
		95	$3\frac{1}{2} \times 3$	$\frac{13}{16}$	15.8	4.65	1.23	5.0	1.04	2.2
				$\frac{3}{4}$	14.7	4.32	1.21	4.7	1.04	2.1
$\frac{11}{16}$	13.6			4.00	1.19	4.4	1.05	1.9		
$\frac{5}{8}$	12.5			3.68	1.17	4.1	1.06	1.8		
$\frac{9}{16}$	11.4			3.35	1.15	3.8	1.07	1.6		
$\frac{1}{2}$	10.2			3.00	1.13	3.5	1.07	1.5		
$\frac{7}{16}$	9.1			2.68	1.10	3.1	1.08	1.3		
$\frac{3}{8}$	7.9			2.32	1.08	2.7	1.09	1.1		
$\frac{5}{16}$	6.6			1.94	1.06	2.3	1.10	.96		
$\frac{1}{4}$	5.4			1.59	1.04	1.9	1.11	.78		
$\frac{3}{16}$	4.2			1.24	1.02	1.5	1.12	.60		
90	$3\frac{1}{2} \times 2\frac{1}{2}$	$\frac{11}{16}$	12.5	3.68	1.27	4.1	1.06	1.9		
		$\frac{5}{8}$	11.5	3.38	1.25	3.8	1.07	1.7		
		$\frac{9}{16}$	10.4	3.06	1.23	3.6	1.08	1.6		
		$\frac{1}{2}$	9.4	2.76	1.20	3.2	1.09	1.4		
		$\frac{7}{16}$	8.3	2.44	1.18	2.9	1.09	1.3		
		$\frac{3}{8}$	7.2	2.12	1.16	2.6	1.10	1.1		
		$\frac{5}{16}$	6.1	1.79	1.14	2.2	1.11	.93		
		$\frac{1}{4}$	4.9	1.44	1.11	1.8	1.12	.75		
		$\frac{3}{16}$	3.71	1.09	1.09	1.4	1.13	.55		

PROPERTIES OF ANGLES UNEQUAL LEGS

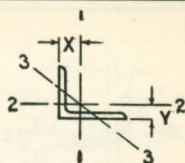

Radius of Fillet, $\frac{3}{8}$ " for
 4×3 " and $3\frac{1}{2} \times 3$ "
 $\frac{1}{4}$ " for $3\frac{1}{2} \times 2\frac{1}{2}$ "

AXIS Z-Z				AXIS 3-3		Thickness, Inches	Size, Inches
Location of Center of Gravity	Moment of Inertia	Radius of Gyration	Section Modulus	Radius of Gyration			
y	I	r	S	r min.			
.96	3.7	.83	1.8	.64	$\frac{7}{8}$	4×3	
.94	3.5	.83	1.7	.64	$\frac{13}{16}$		
.92	3.3	.84	1.6	.64	$\frac{3}{4}$		
.89	3.1	.84	1.5	.64	$\frac{11}{16}$		
.87	2.9	.85	1.4	.64	$\frac{5}{8}$		
.85	2.7	.86	1.2	.64	$\frac{9}{16}$		
.83	2.4	.86	1.1	.64	$\frac{1}{2}$		
.80	2.2	.87	1.0	.64	$\frac{7}{16}$		
.78	1.9	.88	.87	.64	$\frac{3}{8}$		
.76	1.7	.89	.74	.65	$\frac{5}{16}$		
.74	1.4	.89	.60	.65	$\frac{1}{4}$		
.71	1.1	.90	.45	.65	$\frac{3}{16}$		
.98	3.3	.85	1.7	.62	$\frac{13}{16}$	3½×3	
.96	3.1	.85	1.5	.62	$\frac{3}{4}$		
.94	3.0	.86	1.4	.62	$\frac{11}{16}$		
.92	2.8	.87	1.3	.62	$\frac{5}{8}$		
.90	2.5	.87	1.2	.62	$\frac{9}{16}$		
.88	2.3	.88	1.1	.62	$\frac{1}{2}$		
.85	2.1	.89	.98	.62	$\frac{7}{16}$		
.83	1.8	.90	.85	.62	$\frac{3}{8}$		
.81	1.6	.90	.72	.63	$\frac{5}{16}$		
.79	1.3	.91	.58	.63	$\frac{1}{4}$		
.77	.96	.92	.43	.63	$\frac{3}{16}$		
.77	1.7	.69	.99	.53	$\frac{11}{16}$	3½×2½	
.75	1.6	.69	.92	.53	$\frac{5}{8}$		
.73	1.5	.70	.84	.53	$\frac{9}{16}$		
.70	1.4	.70	.76	.53	$\frac{1}{2}$		
.68	1.2	.71	.68	.54	$\frac{7}{16}$		
.66	1.1	.72	.59	.54	$\frac{3}{8}$		
.64	.94	.73	.50	.54	$\frac{5}{16}$		
.61	.78	.74	.41	.54	$\frac{1}{4}$		
.59	.61	.75	.31	.54	$\frac{3}{16}$		

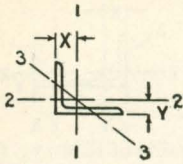
Radius of Fillet, $\frac{1}{4}$ "

PROPERTIES OF ANGLES UNEQUAL LEGS

Section Number	Size, Inches	Thickness, Inches	Weight per Foot, Pounds	Area of Section, Sq. Inches	AXIS 1-1			
					Location of Center of Gravity	Moment of Inertia	Radius of Gyration	Section Modulus
					x	I	r	S
86	$3 \times 2\frac{1}{2}$	$\frac{5}{8}$	11.0	3.23	1.05	2.5	.90	1.3
		$\frac{9}{16}$	9.5	2.79	1.02	2.3	.91	1.2
		$\frac{1}{2}$	8.5	2.50	1.00	2.1	.91	1.0
		$\frac{7}{16}$	7.6	2.24	.98	1.9	.92	.93
		$\frac{3}{8}$	6.6	1.94	.96	1.7	.93	.81
		$\frac{5}{16}$	5.6	1.65	.93	1.4	.94	.69
		$\frac{1}{4}$	4.5	1.32	.91	1.2	.95	.56
		$\frac{3}{16}$	3.4	1.00	.89	.91	.95	.43
109	3×2	$\frac{5}{8}$	10.5	3.09	1.13	2.3	.90	1.2
		$\frac{9}{16}$	9.3	2.74	1.11	2.1	.91	1.1
		$\frac{1}{2}$	7.7	2.26	1.08	1.9	.92	1.0
		$\frac{7}{16}$	6.8	2.00	1.06	1.7	.93	.89
		$\frac{3}{8}$	5.9	1.74	1.04	1.5	.94	.78
		$\frac{5}{16}$	5.0	1.47	1.02	1.3	.95	.66
		$\frac{1}{4}$	4.1	1.21	.99	1.1	.95	.54
		$\frac{3}{16}$	3.1	.91	.97	.84	.97	.41
184	$2\frac{1}{2} \times 2$	$\frac{1}{2}$	6.8	2.00	.88	1.1	.75	.70
		$\frac{7}{16}$	6.1	1.79	.85	1.0	.76	.62
		$\frac{3}{8}$	5.3	1.56	.83	.91	.77	.55
		$\frac{5}{16}$	4.5	1.32	.81	.79	.78	.47
		$\frac{1}{4}$	3.62	1.06	.79	.65	.78	.38
		$\frac{3}{16}$	2.75	.81	.76	.51	.79	.29

PROPERTIES OF ANGLES UNEQUAL LEGS

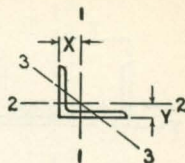
Radius of Fillet, $\frac{1}{4}$ "

AXIS 2-2				AXIS 3-3	Thickness, Inches	Size, Inches
Location of Center of Gravity	Moment of Inertia	Radius of Gyration	Section Modulus	Radius of Gyration		
y	I	r	S	r min.		
.80	1.6	.71	.91	.52	$\frac{5}{8}$	3 × 2½
.77	1.4	.72	.82	.52	$\frac{9}{16}$	
.75	1.3	.72	.74	.52	$\frac{1}{2}$	
.73	1.2	.73	.66	.52	$\frac{7}{16}$	
.71	1.0	.74	.58	.52	$\frac{3}{8}$	
.68	.90	.74	.49	.53	$\frac{5}{16}$	
.66	.74	.75	.40	.53	$\frac{1}{4}$	
.64	.58	.76	.31	.53	$\frac{3}{16}$	
.63	.78	.53	.56	.43	$\frac{5}{8}$	3 × 2
.61	.73	.54	.52	.43	$\frac{9}{16}$	
.58	.67	.55	.47	.43	$\frac{1}{2}$	
.56	.61	.55	.42	.43	$\frac{7}{16}$	
.54	.54	.56	.37	.43	$\frac{3}{8}$	
.52	.47	.57	.32	.43	$\frac{5}{16}$	
.49	.39	.57	.26	.43	$\frac{1}{4}$	
.47	.31	.58	.20	.44	$\frac{3}{16}$	
.63	.64	.56	.46	.42	$\frac{1}{2}$	2½ × 2
.60	.58	.57	.41	.42	$\frac{7}{16}$	
.58	.51	.58	.36	.42	$\frac{3}{8}$	
.56	.45	.58	.31	.42	$\frac{5}{16}$	
.54	.37	.59	.25	.42	$\frac{1}{4}$	
.51	.29	.60	.20	.43	$\frac{3}{16}$	

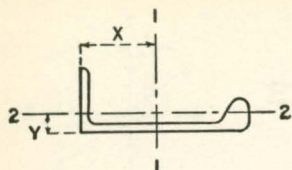

PROPERTIES OF BULB ANGLES

Section Number	Size, Inches	Weight per Foot, Pounds	Thickness of Web T_1 , Inches	Thickness of Flange T_2 , Inches	Width of Bulb N , Inches	Area of Section, Sq. Inches
290	$10 \times 3\frac{1}{2}$	34.7	.70	.64	2.00	10.21
		32.3	.64	.61	1.94	9.50
		29.9	.58	.58	1.88	8.79
		27.2	.52	.485	1.82	8.00
		24.8	.46	.455	1.76	7.29
		22.4	.40	.425	1.70	6.59
291	$9 \times 3\frac{1}{2}$	30.8	.68	.62	1.85	9.06
		28.6	.62	.59	1.79	8.41
		26.4	.56	.56	1.73	7.76
		23.8	.50	.465	1.67	7.00
		21.6	.44	.435	1.61	6.35
		19.4	.38	.405	1.55	5.71
292	$8 \times 3\frac{1}{2}$	24.3	.58	.55	1.62	7.15
		22.3	.52	.52	1.56	6.56
		20.0	.46	.43	1.50	5.88
		18.0	.40	.40	1.44	5.29
		16.0	.34	.37	1.38	4.71

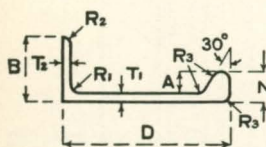

DIMENSIONS OF MINIMUM BULB ANGLE SECTIONS

Section Number	Depth D	Weight	B	A	R_1	R_2	R_3
290	10	22.4	$3\frac{1}{2}$	1.30	.54	.27	.40
291	9	19.4	$3\frac{1}{2}$	1.17	.54	.27	.36
292	8	16.0	$3\frac{1}{2}$	1.04	.54	.27	.32

PROPERTIES
OF
BULB ANGLES

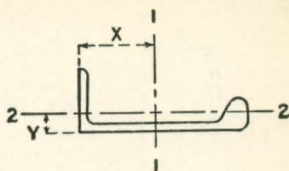

AXIS 1-1				AXIS 2-2				Section Number
Moment of Inertia	Radius of Gyration	Section Modulus	Location of Center of Gravity	Moment of Inertia	Radius of Gyration	Section Modulus	Location of Center of Gravity	
I	r	S	x	I	r	S	y	
125.6	3.51	23.4	4.69	6.8	.81	2.4	.79	290
118.1	3.53	22.1	4.69	6.2	.81	2.2	.77	
110.7	3.55	20.9	4.70	5.6	.80	2.0	.75	
102.9	3.59	19.6	4.80	5.1	.80	1.8	.72	
95.4	3.62	18.4	4.82	4.6	.80	1.6	.70	
88.0	3.66	17.2	4.85	4.1	.79	1.5	.68	
90.1	3.16	18.2	4.11	6.3	.83	2.2	.80	291
84.6	3.18	17.2	4.10	5.7	.83	2.1	.78	
79.0	3.20	16.1	4.10	5.2	.82	1.9	.75	
73.3	3.24	15.1	4.19	4.7	.82	1.7	.72	
67.7	3.27	14.1	4.21	4.2	.82	1.5	.70	
62.2	3.30	13.1	4.22	3.7	.81	1.4	.68	
57.0	2.83	12.7	3.53	5.2	.85	1.9	.78	292
53.0	2.85	11.8	3.52	4.7	.84	1.7	.76	
48.9	2.89	11.1	3.61	4.2	.85	1.5	.72	
44.9	2.92	10.2	3.61	3.7	.84	1.3	.70	
40.9	2.95	9.4	3.62	3.3	.84	1.2	.69	

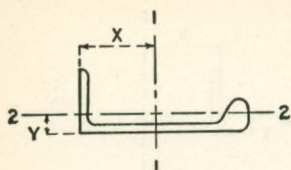

PROPERTIES OF BULB ANGLES

Section Number	Size, Inches	Weight per Foot, Pounds	Thickness of Web T_1 , Inches	Thickness of Flange T_2 , Inches	Width of Bulb N , Inches	Area of Section, Sq. Inches
293	$7 \times 3\frac{1}{2}$	21.1	.56	.54	1.47	6.21
		19.3	.50	.51	1.41	5.68
		17.1	.44	.41	1.35	5.03
		15.3	.38	.38	1.29	4.50
		13.6	.32	.35	1.23	4.00
294	7×3	20.2	.56	.54	1.47	5.94
		18.4	.50	.51	1.41	5.41
		16.4	.44	.41	1.35	4.82
		14.7	.38	.38	1.29	4.32
		12.9	.32	.35	1.23	3.79
295	6×3	16.6	.52	.49	1.30	4.88
		15.0	.46	.46	1.24	4.41
		13.2	.40	.365	1.18	3.88
		11.7	.34	.335	1.12	3.44
		10.1	.28	.305	1.06	2.97
296	$5 \times 2\frac{1}{2}$	12.6	.48	.44	1.13	3.71
		11.3	.42	.41	1.07	3.32
		9.8	.36	.33	1.01	2.88
		8.5	.30	.30	.95	2.50
		7.3	.24	.27	.89	2.15

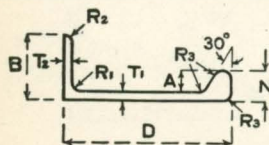

DIMENSIONS OF MINIMUM BULB ANGLE SECTIONS

Section Number	Depth D	Weight	B	A	R_1	R_2	R_3
293	7	13.6	$3\frac{1}{2}$.91	.54	.27	.28
294	7	12.9	3	.91	.48	.24	.28
295	6	10.1	3	.78	.48	.24	.24
296	5	7.3	$2\frac{1}{2}$.65	.42	.21	.20

PROPERTIES
OF
BULB ANGLES

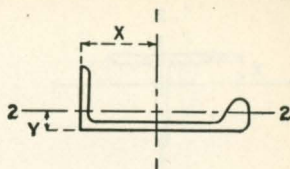

AXIS 1-1				AXIS 2-2				Section Number
Moment of Inertia	Radius of Gyration	Section Modulus	Location of Center of Gravity	Moment of Inertia	Radius of Gyration	Section Modulus	Location of Center of Gravity	
I	r	S	x	I	r	S	y	
37.5	2.46	9.2	2.95	4.8	.88	1.8	.80	293
34.7	2.48	8.6	2.93	4.3	.87	1.6	.78	
32.0	2.52	8.0	3.03	3.9	.88	1.4	.74	
29.2	2.55	7.3	3.02	3.4	.87	1.2	.72	
26.4	2.58	6.7	3.01	3.0	.87	1.1	.71	
35.4	2.45	9.0	3.08	3.1	.72	1.3	.69	294
32.8	2.46	8.3	3.07	2.8	.72	1.2	.67	
30.2	2.50	7.8	3.15	2.5	.72	1.0	.64	
27.5	2.53	7.1	3.15	2.2	.72	.93	.62	
24.9	2.56	6.5	3.15	1.9	.71	.82	.60	
21.4	2.10	6.1	2.53	2.8	.76	1.2	.70	295
19.7	2.11	5.6	2.51	2.5	.75	1.1	.68	
17.9	2.15	5.2	2.59	2.2	.75	.91	.64	
16.2	2.18	4.7	2.58	1.9	.75	.80	.63	
14.5	2.21	4.3	2.58	1.6	.74	.70	.61	
11.1	1.74	3.8	2.12	1.5	.63	.75	.61	296
10.1	1.75	3.5	2.10	1.3	.63	.67	.58	
9.1	1.78	3.1	2.06	1.1	.63	.56	.55	
8.1	1.81	2.7	2.03	.97	.62	.49	.53	
7.1	1.83	2.4	2.01	.81	.62	.42	.51	

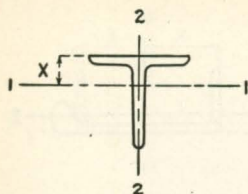

PROPERTIES OF TEE BARS

Section Number	Width of Flange, Inches	Depth of Bar, Inches	Thickness of Flange, Inches	Thickness of Stem, Inches	Weight per Foot, Pounds	Area of Section, Sq. Inches
203	6	5¼	1	1¼ to 1⅜	39.4	11.59
202	6	4½	¾	1⅝ to 1⅞	28.2	8.29

DIMENSIONS OF TEE BAR SECTIONS

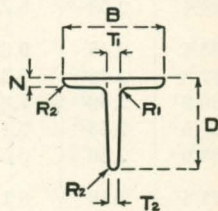

Section Number	Depth D	Weight	B	T ₁	T ₂	N	R ₁	R ₂
203	5¼	39.4	6	1⅜	1¼	1	½	¼
202	4½	28.2	6	1⅞	1⅝	¾	⅜	⅝

**PROPERTIES
OF
TEE BARS**

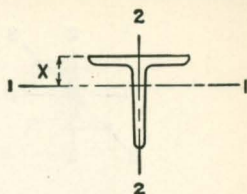

AXIS 1-1				AXIS 2-2			
Moment of Inertia	Radius of Gyration	Section Modulus	Location of Center of Gravity	Moment of Inertia	Radius of Gyration	Section Modulus	Section Number
I	r	S	x	I	r	S	
27.9	1.55	7.9	1.74	18.6	1.27	6.2	203
14.3	1.31	4.6	1.37	13.8	1.29	4.6	202

DIMENSIONS
OF
MINIMUM TEE BAR
SECTIONS

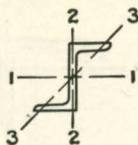

PROPERTIES OF ZEE BARS

Section Number	Depth of Web, Inches	Width of Flanges, Inches	Thickness of Web and Flanges, Inches	Weight per Foot, Pounds	Area of Section, Sq. Inches
243	$6\frac{1}{8}$	$3\frac{5}{8}$	$\frac{7}{8}$	34.6	10.18
	$6\frac{1}{16}$	$3\frac{9}{16}$	$\frac{13}{16}$	32.0	9.41
	6	$3\frac{1}{2}$	$\frac{3}{4}$	29.4	8.65
242	$6\frac{1}{8}$	$3\frac{5}{8}$	$\frac{11}{16}$	28.1	8.26
	$6\frac{1}{16}$	$3\frac{9}{16}$	$\frac{5}{8}$	25.4	7.47
	6	$3\frac{1}{2}$	$\frac{9}{16}$	22.8	6.71
149	$6\frac{1}{8}$	$3\frac{5}{8}$	$\frac{1}{2}$	21.1	6.21
	$6\frac{1}{16}$	$3\frac{9}{16}$	$\frac{7}{16}$	18.4	5.41
	6	$3\frac{1}{2}$	$\frac{3}{8}$	15.7	4.62
234	$5\frac{1}{8}$	$3\frac{3}{8}$	$\frac{13}{16}$	28.4	8.35
	$5\frac{1}{16}$	$3\frac{5}{16}$	$\frac{3}{4}$	26.0	7.65
	5	$3\frac{1}{4}$	$\frac{11}{16}$	23.7	6.97
235	$5\frac{1}{8}$	$3\frac{3}{8}$	$\frac{5}{8}$	22.6	6.65
	$5\frac{1}{16}$	$3\frac{5}{16}$	$\frac{9}{16}$	20.2	5.94
	5	$3\frac{1}{4}$	$\frac{1}{2}$	17.9	5.26
236	$5\frac{1}{8}$	$3\frac{3}{8}$	$\frac{7}{16}$	16.4	4.82
	$5\frac{1}{16}$	$3\frac{5}{16}$	$\frac{3}{8}$	14.0	4.12
	5	$3\frac{1}{4}$	$\frac{5}{16}$	11.6	3.41

DIMENSIONS OF MINIMUM ZEE BAR SECTIONS

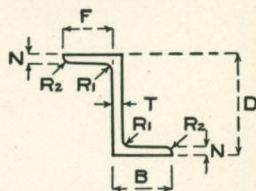

Section Number	Depth D	Weight	B	T	F	N	R ₁	R ₂
243	6	29.4	$3\frac{1}{2}$	$\frac{3}{4}$	$2\frac{3}{4}$	$\frac{3}{4}$	$\frac{5}{16}$	$\frac{3}{16}$
242	6	22.8	$3\frac{1}{2}$	$\frac{9}{16}$	$2\frac{15}{16}$	$\frac{9}{16}$	$\frac{5}{16}$	$\frac{3}{16}$
149	6	15.7	$3\frac{1}{2}$	$\frac{3}{8}$	$3\frac{1}{8}$	$\frac{3}{8}$	$\frac{5}{16}$	$\frac{3}{16}$
234	5	23.7	$3\frac{1}{4}$	$\frac{11}{16}$	$2\frac{9}{16}$	$\frac{11}{16}$	$\frac{5}{16}$	$\frac{3}{16}$
235	5	17.9	$3\frac{1}{4}$	$\frac{1}{2}$	$2\frac{3}{4}$	$\frac{1}{2}$	$\frac{5}{16}$	$\frac{3}{16}$
236	5	11.6	$3\frac{1}{4}$	$\frac{5}{16}$	$2\frac{15}{16}$	$\frac{5}{16}$	$\frac{5}{16}$	$\frac{3}{16}$

PROPERTIES
OF
ZEE BARS

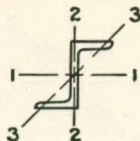

AXIS 1-1			AXIS 2-2			AXIS 3-3	Section Number
Moment of Inertia	Radius of Gyration	Section Modulus	Moment of Inertia	Radius of Gyration	Section Modulus	Radius of Gyration	
I	r	S	I	r	S	r min.	
50.2	2.22	16.4	19.2	1.37	6.0	.83	243
46.1	2.22	15.2	17.3	1.36	5.5	.82	
42.1	2.21	14.0	15.4	1.34	4.9	.81	
43.2	2.29	14.1	16.3	1.41	5.0	.84	242
38.9	2.28	12.8	14.4	1.39	4.4	.82	
34.6	2.28	11.5	12.6	1.37	3.9	.81	
34.4	2.36	11.2	12.9	1.44	3.8	.84	149
29.8	2.35	9.8	11.0	1.43	3.3	.83	
25.3	2.35	8.4	9.1	1.41	2.8	.83	
28.7	1.86	11.2	14.4	1.31	4.8	.76	234
26.2	1.85	10.3	12.8	1.30	4.4	.74	
23.7	1.84	9.5	11.4	1.28	3.9	.73	
24.5	1.92	9.6	12.1	1.35	3.9	.76	235
21.8	1.91	8.6	10.5	1.33	3.5	.75	
19.2	1.91	7.7	9.1	1.31	3.0	.74	
19.1	1.99	7.4	9.2	1.38	2.9	.77	236
16.2	1.99	6.4	7.7	1.37	2.5	.76	
13.4	1.98	5.3	6.2	1.35	2.0	.75	

DIMENSIONS
 OF
 MINIMUM ZEE BAR
 SECTIONS

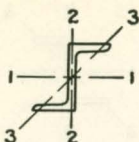

PROPERTIES OF ZEE BARS

Section Number	Depth of Web, Inches	Width of Flanges, Inches	Thickness of Web and Flanges, Inches	Weight per Foot, Pounds	Area of Section, Sq Inches
237	$4\frac{1}{8}$	$3\frac{3}{16}$	$\frac{3}{4}$	23.0	6.76
	$4\frac{1}{16}$	$3\frac{1}{8}$	$\frac{11}{16}$	20.9	6.15
	4	$3\frac{1}{16}$	$\frac{5}{8}$	18.9	5.56
238	$4\frac{1}{8}$	$3\frac{3}{16}$	$\frac{9}{16}$	18.0	5.29
	$4\frac{1}{16}$	$3\frac{1}{8}$	$\frac{1}{2}$	15.9	4.68
	4	$3\frac{1}{16}$	$\frac{7}{16}$	13.8	4.06
239	$4\frac{1}{8}$	$3\frac{3}{16}$	$\frac{3}{8}$	12.5	3.68
	$4\frac{1}{16}$	$3\frac{1}{8}$	$\frac{5}{16}$	10.3	3.03
	4	$3\frac{1}{16}$	$\frac{1}{4}$	8.2	2.41
231	$3\frac{1}{16}$	$2\frac{3}{4}$	$\frac{9}{16}$	14.3	4.21
	3	$2\frac{11}{16}$	$\frac{1}{2}$	12.6	3.71
230	$3\frac{1}{16}$	$2\frac{3}{4}$	$\frac{7}{16}$	11.5	3.38
	3	$2\frac{11}{16}$	$\frac{3}{8}$	9.8	2.88
229	$3\frac{1}{16}$	$2\frac{3}{4}$	$\frac{5}{16}$	8.5	2.50
	3	$2\frac{11}{16}$	$\frac{1}{4}$	6.7	1.97

DIMENSIONS OF MINIMUM ZEE BAR SECTIONS

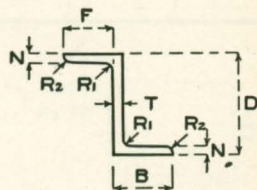

Section Number	Depth D	Weight	B	T	F	N	R ₁	R ₂
237	4	18.9	$3\frac{1}{16}$	$\frac{5}{8}$	$\frac{27}{16}$	$\frac{5}{8}$	$\frac{5}{16}$	$\frac{3}{16}$
238	4	13.8	$3\frac{1}{16}$	$\frac{7}{16}$	$\frac{25}{8}$	$\frac{7}{16}$	$\frac{5}{16}$	$\frac{3}{16}$
239	4	8.2	$3\frac{1}{16}$	$\frac{1}{4}$	$\frac{213}{16}$	$\frac{1}{4}$	$\frac{5}{16}$	$\frac{3}{16}$
231	3	12.6	$2\frac{11}{16}$	$\frac{1}{2}$	$\frac{23}{16}$	$\frac{1}{2}$	$\frac{5}{16}$	$\frac{3}{16}$
230	3	9.8	$2\frac{11}{16}$	$\frac{3}{8}$	$\frac{25}{16}$	$\frac{3}{8}$	$\frac{5}{16}$	$\frac{3}{16}$
229	3	6.7	$2\frac{11}{16}$	$\frac{1}{4}$	$\frac{27}{16}$	$\frac{1}{4}$	$\frac{5}{16}$	$\frac{3}{16}$

PROPERTIES
OF
ZEE BARS

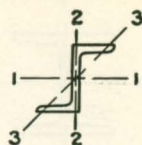

AXIS 1-1			AXIS 2-2			AXIS 3-3	Section Number
Moment of Inertia	Radius of Gyration	Section Modulus	Moment of Inertia	Radius of Gyration	Section Modulus	Radius of Gyration	
I	r	S	I	r	S	r min.	
15.0	1.49	7.3	11.2	1.29	4.0	.68	237
13.5	1.48	6.7	10.0	1.27	3.6	.67	
12.1	1.48	6.1	8.7	1.25	3.2	.66	
12.7	1.55	6.2	9.3	1.33	3.2	.68	238
11.2	1.55	5.5	8.0	1.31	2.8	.67	
9.7	1.55	4.8	6.7	1.29	2.4	.66	
9.6	1.62	4.7	6.8	1.36	2.3	.69	239
7.9	1.62	3.9	5.5	1.34	1.8	.68	
6.3	1.62	3.1	4.2	1.33	1.4	.67	
5.3	1.12	3.4	5.7	1.17	2.3	.54	231
4.6	1.12	3.1	4.9	1.15	2.0	.53	
4.6	1.17	3.0	4.8	1.19	1.9	.55	230
3.9	1.16	2.6	3.9	1.17	1.6	.54	
3.6	1.21	2.4	3.6	1.21	1.4	.56	229
2.9	1.21	1.9	2.8	1.19	1.1	.55	

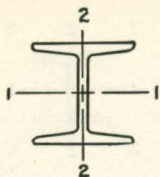

PROPERTIES OF H COLUMNS

Section Number	Depth of Column, Inches	Weight per Foot, Pounds	Area of Section, Sq. Inches	Width of Flange, Inches		Thickness of Web, Inches	
297	8	37.7	11.09	8.125	$8\frac{1}{8}$.500	$\frac{1}{2}$
		34.3	10.09	8.000	8	.375	$\frac{3}{8}$
		32.6	9.59	7.938	$7\frac{15}{16}$.313	$\frac{5}{16}$
287	6	27.5	8.09	6.063	$6\frac{1}{16}$.438	$\frac{7}{16}$
		25.0	7.35	5.938	$5\frac{15}{16}$.313	$\frac{5}{16}$
286	6	22.5	6.62	6.063	$6\frac{1}{16}$.375	$\frac{3}{8}$
		20.0	5.88	5.938	$5\frac{15}{16}$.250	$\frac{1}{4}$

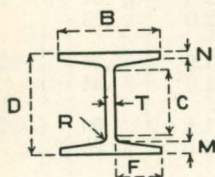

DIMENSIONS OF MINIMUM H COLUMN SECTIONS

Section Number	Depth D	Weight	B	T	F	M	N	C	R
297	8	32.6	7.938	.313	3.813	.560	.358	6.287	.313
287	6	25.0	5.938	.313	2.813	.580	.381	4.256	.313
286	6	20.0	5.938	.250	2.844	.479	.280	4.458	.313

Column Formula, A.I.S.C. Specification, on gross section of columns with a maximum of 15000. In which l is the unsupported length of the column, and r is the corresponding least radius of gyration of the section, both in inches. For main compression members, the ratio $\frac{l}{r}$ shall not exceed 120, and for bracing and other secondary members, 200.

$$1 + \frac{18000}{18000r^2}$$

**PROPERTIES
OF
H COLUMNS**

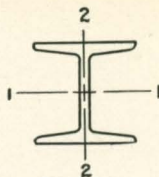

AXIS 1-1			AXIS 2-2			Depth of Column	Section Number
Moment of Inertia	Radius of Gyration	Section Modulus	Moment of Inertia	Radius of Gyration	Section Modulus		
I	r	S	I	r	S	Inches	
120.0	3.31	30.2	36.9	1.83	9.1	8	297
115.5	3.40	28.9	35.1	1.87	8.8		
112.8	3.45	28.2	34.2	1.90	8.6		
49.3	2.47	16.4	16.0	1.41	5.3	6	287
47.0	2.53	15.7	14.9	1.43	5.0		
41.0	2.49	13.7	12.2	1.36	4.0	6	286
38.8	2.57	12.9	11.4	1.39	3.8		

**ALLOWABLE CONCENTRIC LOADS IN THOUSANDS OF POUNDS
FOR H COLUMNS. A.I.S.C. SPECIFICATIONS**

Effective Length in Feet	8" H			6" H			
	37.7 lbs.	34.3 lbs.	32.6 lbs.	27.5 lbs.	25.0 lbs.	22.5 lbs.	20.0 lbs.
4	165	150	143	121	110	99	88
6	165	150	143	121	110	99	88
8	165	150	143	116	106	93	83
9	165	150	143	110	100	88	79
10	160	146	140	104	95	83	75
11	154	141	135	98	90	78	70
12	147	136	130	92	84	73	66
13	141	130	124	87	79	69	62
14	135	124	119	81	75	64	58
15	129	119	114	76	70		
16	123	114	109	72	66	56	51
17	117	108	104	67	62	53	48
18	112	103	100	63	58	50	45
19	106	99	95	59	55	46	42
20	101	94	91	56	51	44	40
22	92	85	83	49	46	38	35
24	83	78	75				
26	76	71	68				
28	69	64	62				
30	63	59	57				

Loads below the heavy horizontal lines are for secondary members only.

NOTES

Faint, illegible text and a large grid table covering the majority of the page. The text is mirrored and difficult to read, appearing to be bleed-through from the reverse side of the paper. The grid table has multiple columns and rows, but the data within is not legible.

PROPERTIES OF COMPOUND SECTIONS

TABLES OF ALLOWABLE
LOADS
A.I.S.C. SPECIFICATIONS



PROPERTIES OF COMPOUND SECTIONS

To find the moment of inertia and radius of gyration of a built section: assume an axis 1-1 through some convenient point, such as, in sketch below, the center of gravity of the web plates. Find the distance "d" from this axis to the center of gravity of each of the component parts of the section. The area of each component part multiplied by its lever arm "d" equals the area moment of that part. The moments of all parts above the axis 1-1 are positive, while those below the axis 1-1 are negative. The algebraic sum of the area moments divided by the sum of the areas equals the eccentricity "e," or distance from the axis 1-1 to the center of gravity of the whole section, "e" being measured above 1-1 if the positive moments exceed the negative, and vice versa.

To the sum of the moments of inertia of each component part about its own center of gravity, add the sum of the products obtained by multiplying the area of each part by the square of the lever arm "d." From this total subtract the product of the total area multiplied by the square of the eccentricity "e." The result is the moment of inertia about the center of gravity of section.

To find the moment of inertia about axis 2-2, through the center of gravity of the section: To the sum of the moments of inertia of each component part about its own center of gravity, add the products of the areas of the component parts each multiplied by the square of the distance "h" between the axis 2-2 and its center of gravity. This result is the moment of inertia of the whole section about axis 2-2.

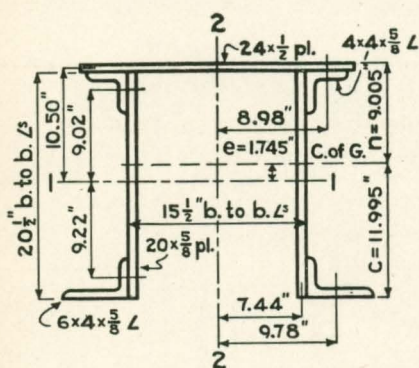

Radius of gyration, about any axis:

$$r = \sqrt{\frac{I}{A}}$$

I = moment of inertia, about that axis;

A = area of cross-section

Section Modulus:

$$S = \frac{I}{c}; S = \frac{I}{n}$$

c and n = distances from center of gravity to extreme fibers.

AXIS 1-1

	Area	d	Area Moment	$Ad^2 + Ig = I_{1-1}$
1-24 \times $\frac{1}{2}$ pl.	12.00	10.5	+ 126.0	1323
2-4 \times 4 \times $\frac{5}{8}$ L ^s	9.22	9.02	+ 83.2	750
2-20 \times $\frac{5}{8}$ pls.	25.00			833
2-6 \times 4 \times $\frac{5}{8}$ L ^s	11.72	9.22	- 108.1	996
Total	57.94		+ 101.1	3930

$$e = \frac{101.1}{57.94} = 1.745"$$

$$I_{1-1} - Ae^2 = I_{c. of g.}$$

$$Ae^2 = 57.94 \times (1.745)^2 = 176$$

$$3930 - 176 = I_{center of gravity}$$

AXIS 2-2

	Area	h	Ah ²	+ Ig = I ₂₋₂
1-24 \times $\frac{1}{2}$ pl.	12.00			576.0
2-4 \times 4 \times $\frac{5}{8}$ L ^s	9.22	8.98	743.5	13.5
2-20 \times $\frac{5}{8}$ pls.	25.00	7.44	1383.8	1.0
2-6 \times 4 \times $\frac{5}{8}$ L ^s	11.72	9.78	1121.0	42.1
Total				3881 = I ₂₋₂

LATERAL DEFLECTION OF BEAMS

In the usual construction of buildings the compression flanges of beams are secured against lateral deflection by the floor system, by tie rods placed at proper intervals, or by other means, and upon this assumption the full tabular loads may be applied.

If, however, the unsupported span exceeds 15 times the flange width, the full tabular safe loads must be reduced in accordance with the various ratios of l/b .

The table below gives the reduction in per cent of the tabular safe loads in accordance with the Specification of the American Institute of Steel Construction. The maximum allowable ratio of l/b is limited to 40.

$$f_c = \frac{20,000}{1 + \frac{1}{2000} (l/b)^2}$$

f_c = allowable compressive stress in pounds per square inch. Full stress 18,000 lbs., up to ratio $l/b = 15$.

l = unsupported length of the compression flange in inches. Maximum allowable ratio $l/b = 40$.

b = width of the flange in inches.

REDUCTION OF TABULAR SAFE LOADS DUE TO LATERAL DEFLECTION

Various Ratios of Span Length to Flange Width of Beam, l/b

American Institute of Steel Construction Specifications

Ratio, Length to Width l/b	Per Cent Tabular Safe Load A.I.S.C. 18,000	Ratio, Length to Width l/b	Per Cent Tabular Safe Load A.I.S.C. 18,000	Ratio, Length to Width l/b	Per Cent Tabular Safe Load A.I.S.C. 18,000	Ratio, Length to Width l/b	Per Cent Tabular Safe Load A.I.S.C. 18,000
		21	91.0	27.5	80.6	34	70.4
15	100.0	21.5	90.3	28	79.8	34.5	69.7
15.5	99.2	22	89.5	28.5	79.0	35	68.9
16	98.5	22.5	88.7	29	78.2	35.5	68.2
16.5	97.8	23	87.9	29.5	77.4	36	67.4
17	97.1	23.5	87.1	30	76.6	36.5	66.7
17.5	96.4	24	86.3	30.5	75.8	37	66.0
18	95.6	24.5	85.5	31	75.1	37.5	65.2
18.5	94.9	25	84.7	31.5	74.3	38	64.5
19	94.1	25.5	83.9	32	73.5	38.5	63.8
19.5	93.4	26	83.0	32.5	72.7	39	63.1
20	92.6	26.5	82.2	33	71.9	39.5	62.4
20.5	91.8	27	81.4	33.5	71.2	40	61.7

ALLOWABLE END REACTIONS FOR STANDARD AND PHOENIX BEAMS

Depth in Inches	Weight per Foot	Value of One Pair Connection Angles	Web t	Unit Stress in Buckling	Reaction R For 3½" Bearing	Min. Span For 3½" Bearing	Reaction R For 5½" Bearing	Increase in R for 1" Additional Bearing	Max. Web Shear V	Span Limit L min.	Length of Bearing to Develop V
20	100.0	59600	.87	15000	110900	8.9'	137000	13050	208800	4.7'	11.0''
	95.0	59600	.80	15000	102000	9.4	126000	12000	192000	5.0	11.0
	90.0	59600	.73	15000	93100	10.1	115000	11000	175200	5.3	11.0
	85.0	59600	.65	15000	82900	10.8	102400	9750	156000	5.8	11.0
	81.4	59600	.60	15000	76500	11.5	94500	9000	144000	6.1	11.0
	75.0	59600	.64	15000	81600	9.3	100800	9600	153600	4.9	11.0
	70.0	59600	.57	14940	72400	10.1	89400	8500	136800	5.4	11.1
	65.4	56250	.50	14210	60400	11.6	74600	7100	120000	5.9	11.9
18	70.0	47700	.71	15000	85300	7.2	106500	10600	153400	4.0	9.9
	65.0	47700	.63	15000	75500	7.8	94400	9450	136100	4.3	9.9
	60.0	47700	.55	15000	66000	8.5	82500	8250	118800	4.7	9.9
	54.7	41400	.46	14350	52800	10.1	66000	6600	99400	5.3	10.5
15	100.0	47700	1.17	15000	127200	5.6	162300	17550	210600	3.4	8.3
	95.0	47700	1.07	15000	116200	6.0	148500	16050	192600	3.6	8.3
	90.0	47700	.97	15000	105500	6.4	134600	14550	174600	3.8	8.3
	85.0	47700	.87	15000	94600	6.9	120700	13050	156600	4.1	8.3
	81.3	47700	.80	15000	87000	7.3	111000	12000	144000	4.4	8.3
	75.0	47700	.87	15000	94600	5.8	120700	13050	156600	3.5	8.3
	70.0	47700	.77	15000	83700	6.3	106800	11550	138600	3.8	8.3
	65.0	47700	.67	15000	72900	6.9	93000	10050	120600	4.2	8.3
	60.8	47700	.59	15000	64200	7.6	81900	8850	106200	4.6	8.3
	55.0	47700	.65	15000	70700	5.8	90200	9750	117000	3.5	8.3
	50.0	47700	.55	15000	59800	6.4	76300	8250	99000	3.9	8.3
	45.0	40500	.45	15000	48900	7.4	62400	6750	81000	4.5	8.3
	42.9	36900	.41	14720	43800	8.1	55900	6050	73800	4.8	8.5
	36.0	26100	.29	12450	26200	12.2	33400	3600	52200	6.1	10.8
12	55.0	35800	.81	15000	79000	4.0	103300	12150	116600	2.7	6.6
	50.0	35800	.69	15000	67300	4.5	88000	10350	99400	3.1	6.6
	45.0	35800	.56	15000	54600	5.2	71400	8400	80600	3.5	6.6
	40.8	31000	.46	15000	44900	6.0	58700	6900	66200	4.1	6.6
	35.0	29000	.43	15000	41900	5.4	54800	6450	61900	3.7	6.6
	31.8	23600	.35	15000	34100	6.3	44600	5250	50400	4.3	6.6
	27.5	20200	.30	14210	27700	6.9	36200	4250	43200	4.4	7.1
	25.0	16200	.24	12710	19800	9.2	25900	3050	34600	5.3	8.3

The beam web is treated as a column with fixed ends, having an effective length l of one-half the beam depth. The unit stress is determined by the A.I.S.C. column formula. The length of web resisting buckling is assumed as the actual bearing on the bracket or wall plate plus one-fourth the beam depth. This agrees with the results of numerous tests.

When the reaction from the load exceeds the allowable reaction R , the beam web must be stiffened or additional length of bearing provided; but in no case shall the reaction exceed the allowable shearing value V .

ALLOWABLE END REACTIONS FOR STANDARD AND PHOENIX BEAMS

Depth in Inches	Weight per Foot	Value of One Pair Connection Angles	Web t	Unit Stress in Buckling	Reaction R For 3 1/2" Bearing	Min. Span For 3 1/2" Bearing	Reaction R For 5 1/2" Bearing	Increase in R for 1" Additional Bearing	Max. Web Shear V	Span Limit L min.	Length of Bearing to Develop V
10	40.0	23800	.74	15000	66700	2.8'	88900	11100	88900	2.1'	5.5"
	35.0	23800	.59	15000	53100	3.3	70800	8850	70800	2.5	5.5
	30.0	23800	.45	15000	40500	4.0	54000	6750	54000	3.0	5.5
	25.4	23800	.31	15000	27900	5.3	37200	4650	37200	3.9	5.5
	21.0	21600	.24	13960	20200	6.5	26800	3350	28800	4.6	6.1
9	35.0	23800	.72	15000	62100	2.4	77800	10800	77800	1.9	5.0
	30.0	23800	.56	15000	48400	2.8	60600	8400	60600	2.2	5.0
	25.0	23800	.39	15000	33600	3.6	42100	5850	42100	2.9	5.0
	21.8	23800	.29	15000	25000	4.5	31300	4350	31300	3.6	5.0
8	25.5	23800	.53	15000	43700	2.3	50900	7950	50900	2.0	4.4
	23.0	23800	.44	15000	36400	2.7	42300	6600	42300	2.3	4.4
	20.5	23800	.35	15000	28800	3.1	33500	5250	33500	2.7	4.4
	18.4	23800	.27	15000	22300	3.8	25900	4050	25900	3.3	4.4
8	21.0	23800	.39	15000	33200	3.0	43900	5850	37400	2.5	4.4
	19.0	23800	.31	15000	25600	3.6	34900	4650	29800	3.0	4.4
	17.0	21600	.24	15000	19800	4.4	27000	3600	23000	3.7	4.4
7	20.0	11900	.45	15000	35400	2.0	37800	6750	37800	1.9	3.9
	17.5	11900	.34	15000	26800	2.5	28600	5100	28600	2.3	3.9
	15.3	11250	.25	15000	19700	3.2	21000	3750	21000	3.0	3.9
6	17.25	11900	.46	15000	33100	1.6	33100	6900	33100	1.6	3.5
	14.75	11900	.34	15000	24500	1.9	24500	5100	24500	1.9	3.3
	12.5	10350	.23	15000	16600	2.6	16600	3450	16600	2.6	3.3
5	14.75	11900	.49	15000	29400	1.2	29400	7350	29400	1.2	2.8
	12.25	11900	.34	15000	20400	1.6	20400	5100	20400	1.6	2.8
	10.0	9450	.21	15000	12600	2.3	12600	3150	12600	2.3	2.8
4	10.5	11900	.40	15000	19200	1.1	19200	6000	19200	1.1	2.2
	9.5	11900	.32	15000	15400	1.3	15400	4800	15400	1.3	2.2
	8.5	11250	.25	15000	12100	1.6	12100	3750	12100	1.6	2.2
	7.7	8550	.19	15000	9100	2.0	9100	2850	9100	2.0	2.2
3	7.5	11900	.35	15000	12600	.9	12600	5250	12600	.9	1.7
	6.5	11250	.25	15000	9000	1.2	9000	3750	9000	1.2	1.7
	5.7	7650	.17	15000	6100	1.6	6100	2550	6100	1.6	1.7

The beam web is treated as a column with fixed ends, having an effective length l of one-half the beam depth. The unit stress is determined by the A.I.S.C. column formula. The length of web resisting buckling is assumed as the actual bearing on the bracket or wall plate plus one-fourth the beam depth. This agrees with the results of numerous tests.

When the reaction from the load exceeds the allowable reaction R , the beam web must be stiffened or additional length of bearing provided; but in no case shall the reaction exceed the allowable shearing value V .

BEAMS

ALLOWABLE UNIFORM LOADS IN THOUSANDS OF POUNDS
FOR BEAMS BRACED AGAINST LATERAL DEFLECTION

Maximum fiber stress, 18,000 pounds per square inch

Span in Feet	20" I NO. 208					20" I NO. 206		
	100 lbs.	95 lbs.	90 lbs.	85 lbs.	81.4 lbs.	75 lbs.	70 lbs.	65.4 lbs.
10	197.8	191.9	186.1	180.2	175.9	152.3	146.4	141.0
11	179.8	174.5	169.1	163.8	159.9	138.4	133.1	128.1
12	164.9	160.0	155.1	150.2	146.6	126.9	122.0	117.5
13	152.2	147.6	143.1	138.6	135.3	117.1	112.6	108.4
14	141.3	137.1	132.9	128.7	125.7	108.8	104.5	100.7
15	131.9	128.0	124.0	120.1	117.3	101.5	97.6	94.0
16	123.6	120.0	116.3	112.6	110.0	95.2	91.5	88.1
17	116.4	112.9	109.4	106.0	103.5	89.6	86.1	82.9
18	109.9	106.6	103.4	100.1	97.7	84.6	81.3	78.3
19	104.1	101.0	97.9	94.8	92.6	80.1	77.0	74.2
20	98.9	96.0	93.0	90.1	88.0	76.1	73.2	70.5
21	94.2	91.4	88.6	85.8	83.8	72.5	69.7	67.1
22	89.9	87.2	84.6	81.9	80.0	69.2	66.5	64.1
23	86.0	83.5	80.9	78.3	76.5	66.2	63.6	61.3
24	82.4	80.0	77.5	75.1	73.3	63.4	61.0	58.7
25	79.1	76.8	74.4	72.1	70.4	60.9	58.5	56.4
26	76.1	73.8	71.6	69.3	67.7	58.6	56.3	54.2
27	73.3	71.1	68.9	66.7	65.2	56.4	54.2	52.2
28	70.7	68.6	66.5	64.4	62.9	54.4	52.3	50.3
29	68.2	66.2	64.2	62.1	60.7	52.5	50.5	48.6
30	65.9	64.0	62.0	60.1	58.6	50.8	48.8	47.0
31	63.8	61.9	60.0	58.1	56.8	49.1	47.2	45.5
32	61.8	60.0	58.1	56.3	55.0	47.6	45.7	44.0
33	59.9	58.2	56.4	54.6	53.3	46.1	44.4	42.7
34	58.2	56.5	54.7	53.0	51.7	44.8	43.0	41.5
35	56.5	54.8	53.2	51.5	50.3	43.5	41.8	40.3
36	55.0	53.3	51.7	50.1	48.9	42.3	40.7	39.2
37	53.5	51.9	50.3	48.7	47.6	41.2	39.6	38.1
38	52.1	50.5	49.0	47.4	46.3	40.1	38.5	37.1
39	50.7	49.2	47.7	46.2	45.1	39.0	37.5	36.1
40	49.5	48.0	46.5	45.0	44.0	38.1	36.6	35.2
41	48.3	46.8	45.4	43.9	42.9	37.1	35.7	34.4
42	47.1	45.7	44.3	42.9	41.9	36.3	34.8	33.6

Special connection angles must be used for loads above the dotted line.

BEAMS

ALLOWABLE UNIFORM LOADS IN THOUSANDS OF POUNDS
FOR BEAMS BRACED AGAINST LATERAL DEFLECTION

Maximum fiber stress, 18,000 pounds per square inch

Span in Feet	18" I NO. 207				15" I NO. 161				
	70 lbs.	65 lbs.	60 lbs.	54.7 lbs.	100 lbs.	95 lbs.	90 lbs.	85 lbs.	81.3 lbs.
10	122.8	117.5	112.3	106.6	143.8	139.4	135.0	130.5	127.3
11	111.7	106.9	102.0	96.9	130.7	126.7	122.7	118.7	115.7
12	102.4	98.0	93.5	88.9	119.8	116.1	112.5	108.8	106.1
13	94.5	90.4	86.3	82.0	110.6	107.2	103.8	100.4	97.9
14	87.7	84.0	80.2	76.2	102.7	99.6	96.4	93.2	90.9
15	81.9	78.4	74.8	71.1	95.9	92.9	90.0	87.0	84.9
16	76.8	73.5	70.2	66.7	89.9	87.1	84.4	81.6	79.6
17	72.3	69.1	66.0	62.7	84.6	82.0	79.4	76.8	74.9
18	68.2	65.3	62.4	59.2	79.9	77.4	75.0	72.5	70.7
19	64.7	61.9	59.1	56.1	75.7	73.4	71.0	68.7	67.0
20	61.4	58.8	56.1	53.3	71.9	69.7	67.5	65.3	63.6
21	58.5	56.0	53.5	50.8	68.5	66.4	64.3	62.2	60.6
22	55.8	53.4	51.0	48.5	65.4	63.4	61.3	59.3	57.9
23	53.4	51.1	48.8	46.4	62.5	60.6	58.7	56.8	55.3
24	51.2	49.0	46.8	44.4	60.0	58.1	56.2	54.4	53.0
25	49.1	47.0	44.9	42.7	57.5	55.8	54.0	52.2	50.9
26	47.2	45.2	43.2	41.0	55.3	53.6	51.9	50.2	49.0
27	45.5	43.5	41.6	39.5	53.3	51.6	50.0	48.3	47.1
28	43.9	42.0	40.1	38.1	51.3	49.8	48.2	46.6	45.5
29	42.4	40.5	38.7	36.8	49.6	48.1	46.5	45.0	43.9
30	40.9	39.2	37.4	35.5	47.9	46.5	45.0	43.5	42.4
31	39.6	37.9	36.2	34.4	46.4	45.0	43.5	42.1	41.1
32	38.4	36.7	35.1	33.3	44.9	43.6	42.2	40.8	39.7
33	37.2	35.6	34.0	32.3	43.6	42.2	40.9	39.6	38.6
34	36.1	34.6	33.0	31.4	42.3	41.0	39.7	38.4	37.4
35	35.1	33.6	32.1	30.5	41.1	39.8	38.6	37.3	36.4
36	34.1	32.7	31.2	29.6	39.9	38.7	37.5	36.3	35.4

Special connection angles must be used for loads above the dotted line.

BEAMS

ALLOWABLE UNIFORM LOADS IN THOUSANDS OF POUNDS
FOR BEAMS BRACED AGAINST LATERAL DEFLECTION

Maximum fiber stress, 18,000 pounds per square inch

Span in Feet	15" I NO. 162				15" I NO. 164				15" I NO. 252
	75 lbs.	70 lbs.	65 lbs.	60.8 lbs.	55 lbs.	50 lbs.	45 lbs.	42.9 lbs.	36 lbs.
10	110.6	106.2	101.8	98.1	81.8	77.3	72.9	71.1	64.1
11	100.6	96.5	92.5	89.1	74.3	70.3	66.3	64.6	58.3
12	92.2	88.5	84.8	81.7	68.1	64.5	60.8	59.2	53.5
13	85.1	81.7	78.3	75.4	62.9	59.5	56.1	54.7	49.3
14	79.0	75.9	72.7	70.0	58.4	55.2	52.1	50.8	45.8
15	73.7	70.8	67.9	65.4	54.5	51.6	48.6	47.4	42.8
16	69.1	66.4	63.6	61.3	51.1	48.3	45.6	44.4	40.1
17	65.1	62.5	59.9	57.7	48.1	45.5	42.9	41.8	37.7
18	61.4	59.0	56.5	54.5	45.4	43.0	40.5	39.5	35.6
19	58.2	55.9	53.6	51.6	43.0	40.7	38.4	37.4	33.8
20	55.3	53.1	50.9	49.0	40.9	38.7	36.5	35.5	32.1
21	52.7	50.6	48.5	46.7	38.9	36.8	34.7	33.9	30.5
22	50.3	48.3	46.3	44.6	37.2	35.2	33.1	32.3	29.2
23	48.1	46.2	44.3	42.7	35.5	33.6	31.7	30.9	27.9
24	46.1	44.2	42.4	40.9	34.1	32.2	30.4	29.6	26.7
25	44.2	42.5	40.7	39.2	32.7	30.9	29.2	28.4	25.7
26	42.5	40.8	39.1	37.7	31.4	29.7	28.0	27.3	24.7
27	41.0	39.3	37.7	36.3	30.3	28.6	27.0	26.3	23.8
28	39.5	37.9	36.3	35.0	29.2	27.6	26.0	25.4	22.9
29	38.1	36.6	35.1	33.8	28.2	26.7	25.1	24.5	22.1
30	36.9	35.4	33.9	32.7	27.3	25.8	24.3	23.7	21.4
31	35.7	34.3	32.8	31.6	26.4	24.9	23.5	22.9	20.7
32	34.6	33.2	31.8	30.6	25.6	24.2	22.8	22.2	20.0
33	33.5	32.2	30.8	29.7	24.8	23.4	22.1	21.5	19.4
34	32.5	31.2	29.9	28.8	24.0	22.7	21.4	20.9	18.9
35	31.6	30.3	29.1	28.0	23.4	22.1	20.8	20.3	18.3
36	30.7	29.5	28.3	27.2	22.7	21.5	20.3	19.7	17.8

Special connection angles must be used for loads above the dotted line.

BEAMS

ALLOWABLE UNIFORM LOADS IN THOUSANDS OF POUNDS
FOR BEAMS BRACED AGAINST LATERAL DEFLECTION

Maximum fiber stress, 18,000 pounds per square inch

Span in Feet	12" I NO. 165				12" I NO. 166		12" I NO. 288	
	55 lbs.	50 lbs.	45 lbs.	40.8 lbs.	35 lbs.	31.8 lbs.	27.5 lbs.	25 lbs.
10	64.2	60.7	57.1	54.2	45.7	43.4	38.1	36.3
11	58.4	55.1	51.9	49.3	41.5	39.5	34.6	33.0
12	53.5	50.6	47.6	45.2	38.1	36.2	31.7	30.3
13	49.4	46.7	44.0	41.7	35.1	33.4	29.3	27.9
14	45.9	43.3	40.8	38.7	32.6	31.0	27.2	25.9
15	42.8	40.4	38.1	36.1	30.4	28.9	25.4	24.2
16	40.1	37.9	35.7	33.9	28.5	27.1	23.8	22.7
17	37.8	35.7	33.6	31.9	26.9	25.5	22.4	21.4
18	35.7	33.7	31.7	30.1	25.4	24.1	21.2	20.2
19	33.8	31.9	30.1	28.5	24.0	22.8	20.0	19.1
20	32.1	30.3	28.6	27.1	22.8	21.7	19.0	18.2
21	30.6	28.9	27.2	25.8	21.7	20.7	18.1	17.3
22	29.2	27.6	26.0	24.6	20.8	19.7	17.3	16.5
23	27.9	26.4	24.8	23.6	19.9	18.9	16.5	15.8
24	26.8	25.3	23.8	22.6	19.0	18.1	15.9	15.1
25	25.7	24.3	22.9	21.7	18.3	17.4	15.2	14.5
26	24.7	23.3	22.0	20.8	17.6	16.7	14.6	14.0
27	23.8	22.5	21.2	20.1	16.9	16.1	14.1	13.4
28	22.9	21.7	20.4	19.4	16.3	15.5	13.6	13.0
29	22.1	20.9	19.7	18.7	15.7	15.0	13.1	12.5
30	21.4	20.2	19.0	18.1	15.2	14.5	12.7	12.1
31	20.7	19.6	18.4	17.5	14.7	14.0	12.3	11.7
32	20.1	19.0	17.8	16.9	14.3	13.6	11.9	11.3
33	19.5	18.4	17.3	16.4	13.8	13.2	11.5	11.0
34	18.9	17.8	16.8	15.9	13.4	12.8	11.2	10.7
35	18.3	17.3	16.3	15.5	13.0	12.4	10.9	10.4
36	17.8	16.9	15.9	15.1	12.7	12.1	10.6	10.1

Special connection angles must be used for loads above the dotted line.

BEAMS

ALLOWABLE UNIFORM LOADS IN THOUSANDS OF POUNDS
FOR BEAMS BRACED AGAINST LATERAL DEFLECTION

Maximum fiber stress, 18,000 pounds per square inch

Span in Feet	10" I NO. 221				10" I NO. 289	9" I NO. 209			
	40 lbs.	35 lbs.	30 lbs.	25.4 lbs.	21 lbs.	35 lbs.	30 lbs.	25 lbs.	21.8 lbs.
6	63.5	58.6	53.7	49.2	43.4	49.7	45.3	40.9	38.0
7	54.4	50.2	46.0	42.1	37.2	42.6	38.8	35.0	32.6
8	47.6	44.0	40.3	36.9	32.6	37.3	34.0	30.7	28.5
9	42.3	39.1	35.8	32.8	29.0	33.1	30.2	27.3	25.4
10	38.1	35.2	32.2	29.5	26.1	29.8	27.2	24.5	22.8
11	34.6	32.0	29.3	26.8	23.7	27.1	24.7	22.3	20.8
12	31.7	29.3	26.8	24.6	21.7	24.8	22.6	20.4	19.0
13	29.3	27.0	24.8	22.7	20.0	22.9	20.9	18.9	17.6
14	27.2	25.1	23.0	21.1	18.6	21.3	19.4	17.5	16.3
15	25.4	23.4	21.5	19.7	17.4	19.9	18.1	16.4	15.2
16	23.8	22.0	20.1	18.4	16.3	18.6	17.0	15.3	14.3
17	22.4	20.7	18.9	17.4	15.3	17.5	16.0	14.4	13.4
18	21.2	19.5	17.9	16.4	14.5	16.6	15.1	13.6	12.7
19	20.0	18.5	17.0	15.5	13.7	15.7	14.3	12.9	12.0
20	19.0	17.6	16.1	14.7	13.0	14.9	13.6	12.3	11.4
21	18.1	16.7	15.3	14.0	12.4	14.2	12.9	11.7	10.9
22	17.3	16.0	14.6	13.4	11.8	13.6	12.4	11.2	10.4
23	16.6	15.3	14.0	12.8	11.3	13.0	11.8	10.7	9.9
24	15.9	14.7	13.4	12.3	10.9	12.4	11.3	10.2	9.5
25	15.2	14.1	12.9	11.8	10.4	11.9	10.9	9.8	9.1
26	14.6	13.5	12.4	11.3	10.0	11.5	10.5	9.4	8.8
27	14.1	13.0	11.9	10.9	9.7	11.0	10.1	9.1	8.5
28	13.6	12.6	11.5	10.5	9.3	10.6	9.7	8.8	8.2
29	13.1	12.1	11.1	10.2	9.0	10.3	9.4	8.5	7.9
30	12.7	11.7	10.7	9.8	8.7	9.9	9.1	8.2	7.6
31	12.3	11.3	10.4	9.5	8.4	9.6	8.8	7.9	7.4
32	11.9	11.0	10.1	9.2	8.1	9.3	8.5	7.7	7.1

Special connection angles must be used for loads above the dotted line.

BEAMS

ALLOWABLE UNIFORM LOADS IN THOUSANDS OF POUNDS
FOR BEAMS BRACED AGAINST LATERAL DEFLECTION

Maximum fiber stress, 18,000 pounds per square inch

Span in Feet	8" I NO. 210				8" I NO. 298			7" I NO. 211		
	25.5 lbs.	23.0 lbs.	20.5 lbs.	18.4 lbs.	21.0 lbs.	19.0 lbs.	17.0 lbs.	20.0 lbs.	17.5 lbs.	15.3 lbs.
4	51.3	48.4	45.5	43.0	46.8	44.4	42.0	36.2	33.6	31.3
5	41.0	38.7	36.4	34.4	37.4	35.5	33.6	28.9	26.7	25.0
6	34.2	32.3	30.3	28.7	31.2	29.6	28.0	24.1	22.4	20.9
7	29.3	27.6	26.0	24.6	26.7	25.4	24.0	20.7	19.2	17.9
8	25.7	24.2	22.7	21.5	23.4	22.2	21.0	18.1	16.8	15.6
9	22.8	21.5	20.2	19.1	20.8	19.7	18.7	16.1	14.9	13.9
10	20.5	19.4	18.2	17.2	18.7	17.8	16.8	14.5	13.4	12.5
11	18.7	17.6	16.5	15.6	17.0	16.1	15.3	13.2	12.2	11.4
12	17.1	16.1	15.2	14.3	15.6	14.8	14.0	12.1	11.2	10.4
13	15.8	14.9	14.0	13.2	14.4	13.7	12.9	11.1	10.3	9.6
14	14.7	13.8	13.0	12.3	13.4	12.7	12.0	10.3	9.6	8.9
15	13.7	12.9	12.1	11.5	12.5	11.8	11.2	9.6	9.0	8.3
16	12.8	12.1	11.4	10.7	11.7	11.1	10.5	9.0	8.4	7.8
17	12.1	11.4	10.7	10.1	11.0	10.5	9.9	8.5	7.9	7.4
18	11.4	10.8	10.1	9.6	10.4	9.9	9.4	8.0	7.5	7.0
19	10.8	10.2	9.6	9.0	9.9	9.4	8.8	7.6	7.1	6.6
20	10.3	9.7	9.1	8.6	9.4	8.9	8.4	7.2	6.7	6.3
21	9.8	9.2	8.7	8.2	8.9	8.5	8.0	6.9	6.4	6.0
22	9.3	8.8	8.3	7.8	8.5	8.1	7.6	6.6	6.1	5.7
23	8.9	8.4	7.9	7.5	8.2	7.7	7.3	6.3	5.8	5.4
24	8.6	8.1	7.6	7.2	7.8	7.4	7.0	6.0	5.6	5.2
25	8.2	7.7	7.3	6.9	7.5	7.1	6.7	5.8	5.4	5.0
26	7.9	7.4	7.0	6.6	7.2	6.8	6.5	5.6	5.2	4.8
27	7.6	7.2	6.8	6.4	6.9	6.6	6.2	5.4	5.0	4.6

Special connection angles must be used for loads above the dotted line.

BEAMS

ALLOWABLE UNIFORM LOADS IN THOUSANDS OF POUNDS
FOR BEAMS BRACED AGAINST LATERAL DEFLECTION

Maximum fiber stress, 18,000 pounds per square inch

Span in Feet	6" I NO. 212			5" I NO. 214		
	17.25 lbs.	14.75 lbs.	12.5 lbs.	14.75 lbs.	12.25 lbs.	10.0 lbs.
4	26.2	24.0	22.0	18.2	16.3	14.6
5	21.0	19.2	17.6	14.6	13.1	11.7
6	17.5	16.0	14.7	12.2	10.9	9.8
7	15.0	13.7	12.6	10.4	9.3	8.4
8	13.1	12.0	11.0	9.1	8.2	7.3
9	11.6	10.7	9.8	8.1	7.3	6.5
10	10.5	9.6	8.8	7.3	6.5	5.9
11	9.5	8.7	8.0	6.6	5.9	5.3
12	8.7	8.0	7.3	6.1	5.4	4.9
13	8.1	7.4	6.8	5.6	5.0	4.5
14	7.5	6.9	6.3	5.2	4.7	4.2
15	7.0	6.4	5.9	4.9	4.4	3.9

Span in Feet	4" I NO. 213				3" I NO. 222		
	10.5 lbs.	9.5 lbs.	8.5 lbs.	7.7 lbs.	7.5 lbs.	6.5 lbs.	5.7 lbs.
4	10.7	10.2	9.6	9.0	5.8	5.4	5.0
5	8.5	8.2	7.7	7.2	4.6	4.3	4.0
6	7.1	6.8	6.4	6.0	3.9	3.6	3.3
7	6.1	5.8	5.5	5.1	3.3	3.1	2.9
8	5.3	5.1	4.8	4.5	2.9	2.7	2.5
9	4.7	4.5	4.3	4.0	2.6	2.4	2.2
10	4.3	4.1	3.8	3.6	2.3	2.2	2.0
11	3.9	3.7	3.5	3.3	2.1	2.0	1.8
12	3.6	3.4	3.2	3.0	1.9	1.8	1.7
13	3.3	3.1	3.0	2.8	1.8	1.7	1.5
14	3.0	2.9	2.7	2.6	1.7	1.5	1.4
15	2.8	2.7	2.6	2.4	1.5	1.4	1.3

Special connection angles must be used for loads above the dotted line.

CHANNELS

ALLOWABLE UNIFORM LOADS IN THOUSANDS OF POUNDS
FOR CHANNELS BRACED AGAINST LATERAL DEFLECTION

Maximum fiber stress, 18,000 pounds per square inch

Span in Feet	15" C NO. 140					
	55 lbs.	50 lbs.	45 lbs.	40 lbs.	35 lbs.	33.9 lbs.
6	114.7	107.4	100.0	92.7	85.3	83.7
7	98.3	92.0	85.7	79.4	73.1	71.7
8	86.0	80.5	75.0	69.5	64.0	62.8
9	76.5	71.6	66.7	61.8	56.9	55.8
10	68.8	64.4	60.0	55.6	51.2	50.2
11	62.6	58.6	54.6	50.5	46.5	45.7
12	57.4	53.7	50.0	46.3	42.7	41.9
13	53.0	49.6	46.2	42.8	39.4	38.6
14	49.2	46.0	42.9	39.7	36.6	35.9
15	45.9	43.0	40.0	37.1	34.1	33.5
16	43.0	40.3	37.5	34.8	32.0	31.4
17	40.5	37.9	35.3	32.7	30.1	29.5
18	38.2	35.8	33.3	30.9	28.4	27.9
19	36.2	33.9	31.6	29.3	26.9	26.4
20	34.4	32.2	30.0	27.8	25.6	25.1
21	32.8	30.7	28.6	26.5	24.4	23.9
22	31.3	29.3	27.3	25.3	23.3	22.8
23	29.9	28.0	26.1	24.2	22.3	21.8
24	28.7	26.8	25.0	23.2	21.3	20.9
25	27.5	25.8	24.0	22.2	20.5	20.1
26	26.5	24.8	23.1	21.4	19.7	19.3
27	25.5	23.9	22.2	20.6	19.0	18.6
28	24.6	23.0	21.4	19.9	18.3	17.9
29	23.7	22.2	20.7	19.2	17.7	17.3
30	22.9	21.5	20.0	18.5	17.1	16.7
31	22.2	20.8	19.4	17.9	16.5	16.2
32	21.5	20.1	18.8	17.4	16.0	15.7

CHANNELS

ALLOWABLE UNIFORM LOADS IN THOUSANDS OF POUNDS
FOR CHANNELS BRACED AGAINST LATERAL DEFLECTION

Maximum fiber stress, 18,000 pounds per square inch

Span in Feet	12" C NO. 141				
	40 lbs.	35 lbs.	30 lbs.	25 lbs.	20.7 lbs.
4			80.8	72.0	64.4
5			64.6	57.6	51.5
6	65.6	59.8	53.9	48.0	42.9
7	56.3	51.2	46.2	41.1	36.8
8	49.2	44.8	40.4	36.0	32.2
9	43.8	39.8	35.9	32.0	28.6
10	39.4	35.9	32.3	28.8	25.8
11	35.8	32.6	29.4	26.2	23.4
12	32.8	29.9	26.9	24.0	21.5
13	30.3	27.6	24.9	22.1	19.8
14	28.1	25.6	23.1	20.6	18.4
15	26.3	23.9	21.5	19.2	17.2
16	24.6	22.4	20.2	18.0	16.1
17	23.2	21.1	19.0	16.9	15.2
18	21.9	19.9	18.0	16.0	14.3
19	20.7	18.9	17.0	15.2	13.6
20	19.7	17.9	16.2	14.4	12.9
21	18.8	17.1	15.4	13.7	12.3
22	17.9	16.3	14.7	13.1	11.7
23	17.1	15.6	14.1	12.5	11.2
24	16.4	14.9	13.5	12.0	10.7
25	15.8	14.3	12.9	11.5	10.3
26	15.1	13.8	12.4	11.1	9.9
27	14.6	13.3	12.0	10.7	9.5
28	14.1	12.8	11.5	10.3	9.2
29	13.6	12.4	11.1	9.9	8.9
30	13.1	12.0	10.8	9.6	8.6
31	12.7	11.6			
32	12.3	11.2			

CHANNELS

ALLOWABLE UNIFORM LOADS IN THOUSANDS OF POUNDS
FOR CHANNELS BRACED AGAINST LATERAL DEFLECTION

Maximum fiber stress, 18,000 pounds per square inch

Span in Feet	10" C NO. 130					9" C NO. 233	
	35 lbs.	30 lbs.	25 lbs.	20 lbs.	15.3 lbs.	25 lbs.	20 lbs.
4	69.3	61.9	54.6	47.2	40.3	47.2	40.5
5	55.4	49.5	43.7	37.8	32.3	37.7	32.4
6	46.2	41.3	36.4	31.5	26.9	31.4	27.0
7	39.6	35.4	31.2	27.0	23.0	27.0	23.2
8	34.6	31.0	27.3	23.6	20.2	23.6	20.3
9	30.8	27.5	24.3	21.0	17.9	21.0	18.0
10	27.7	24.8	21.8	18.9	16.1	18.9	16.2
11	25.2	22.5	19.8	17.2	14.7	17.2	14.7
12	23.1	20.6	18.2	15.7	13.4	15.7	13.5
13	21.3	19.1	16.8	14.5	12.4	14.5	12.5
14	19.8	17.7	15.6	13.5	11.5	13.5	11.6
15	18.5	16.5	14.6	12.6	10.8	12.6	10.8
16	17.2	15.5	13.6	11.8	10.1	11.8	10.1
17	16.3	14.6	12.8	11.1	9.5	11.1	9.5
18	15.4	13.8	12.1	10.5	9.0	10.5	9.0
19	14.6	13.0	11.5	9.9	8.5	9.9	8.5
20	13.9	12.4	10.9	9.4	8.1	9.4	8.1
21	13.2	11.8	10.4	9.0	7.7	9.0	7.7
22	12.6	11.3	9.9	8.6	7.3	8.6	7.4
23	12.0	10.8	9.5	8.2	7.0	8.2	7.1
24	11.5	10.3	9.1	7.9	6.7	7.9	6.8
25	11.1	9.9	8.7	7.6	6.5	7.5	6.5
26	10.7	9.5	8.4	7.3	6.2	7.3	6.2
27	10.3	9.2	8.1	7.0	6.0	7.0	6.0
28	9.9	8.8	7.8	6.7	5.8		
29	9.6	8.5	7.5	6.5	5.6		
30	9.2	8.3	7.3	6.3	5.4		

CHANNELS

ALLOWABLE UNIFORM LOADS IN THOUSANDS OF POUNDS
FOR CHANNELS BRACED AGAINST LATERAL DEFLECTION

Maximum fiber stress, 18,000 pounds per square inch

Span in Feet	9" C NO. 233		8" C NO. 122				
	15 lbs.	13.4 lbs.	21.25 lbs.	18.75 lbs.	16.25 lbs.	13.75 lbs.	11.5 lbs.
4	33.9	31.8	35.8	32.9	29.9	27.0	24.4
5	27.1	25.4	28.7	26.3	24.0	21.6	19.5
6	22.6	21.2	23.9	21.9	20.0	18.0	16.2
7	19.4	18.2	20.5	18.8	17.1	15.4	13.9
8	17.0	15.9	17.9	16.4	15.0	13.5	12.2
9	15.1	14.1	15.9	14.6	13.3	12.0	10.8
10	13.6	12.7	14.3	13.2	12.0	10.8	9.7
11	12.3	11.6	13.0	12.0	10.9	9.8	8.9
12	11.3	10.6	11.9	11.0	10.0	9.0	8.1
13	10.4	9.8	11.0	10.1	9.2	8.3	7.5
14	9.7	9.1	10.2	9.4	8.6	7.7	7.0
15	9.0	8.5	9.6	8.8	8.0	7.2	6.5
16	8.5	8.0	9.0	8.2	7.5	6.7	6.1
17	8.0	7.5	8.4	7.7	7.0	6.4	5.7
18	7.5	7.1	8.0	7.3	6.7	6.0	5.4
19	7.1	6.7	7.5	6.9	6.3	5.7	5.1
20	6.8	6.4	7.2	6.6	6.0	5.4	4.9
21	6.5	6.1	6.8	6.3	5.7	5.1	4.6
22	6.2	5.8	6.5	6.0	5.4	4.9	4.4
23	5.9	5.5	6.2	5.7	5.2	4.7	4.2
24	5.7	5.3	6.0	5.5	5.0	4.5	4.1
25	5.4	5.1	5.7	5.3	4.8	4.3	3.9
26	5.2	4.9	5.5	5.1	4.6	4.2	3.7
27	5.0	4.7	5.3	4.9	4.4	4.0	3.6

CHANNELS

ALLOWABLE UNIFORM LOADS IN THOUSANDS OF POUNDS
FOR CHANNELS BRACED AGAINST LATERAL DEFLECTION

Maximum fiber stress, 18,000 pounds per square inch

Span in Feet	7" C NO. 136					6" C NO. 144			
	19.75 lbs.	17.25 lbs.	14.75 lbs.	12.25 lbs.	9.8 lbs.	15.5 lbs.	13.0 lbs.	10.5 lbs.	8.2 lbs.
4	28.4	25.9	23.3	20.7	18.2	19.5	17.3	15.1	13.1
5	22.7	20.7	18.6	16.6	14.6	15.6	13.9	12.1	10.5
6	19.0	17.2	15.5	13.8	12.1	13.0	11.6	10.1	8.7
7	16.2	14.8	13.3	11.8	10.4	11.2	9.9	8.6	7.5
8	14.2	12.9	11.6	10.4	9.1	9.8	8.7	7.6	6.5
9	12.6	11.5	10.3	9.2	8.1	8.7	7.7	6.7	5.8
10	11.4	10.3	9.3	8.3	7.3	7.8	6.9	6.0	5.2
11	10.3	9.4	8.5	7.5	6.6	7.1	6.3	5.5	4.8
12	9.5	8.6	7.8	6.9	6.1	6.5	5.8	5.0	4.4
13	8.7	8.0	7.2	6.4	5.6	6.0	5.3	4.7	4.0
14	8.1	7.4	6.7	5.9	5.2	5.6	5.0	4.3	3.7
15	7.6	6.9	6.2	5.5	4.9	5.2	4.6	4.0	3.5
16	7.1	6.5	5.8	5.2	4.5	4.9	4.3	3.8	3.3
17	6.7	6.1	5.5	4.9	4.3	4.6	4.1	3.6	3.1
18	6.3	5.7	5.2	4.6	4.0	4.3	3.9	3.4	2.9
19	6.0	5.4	4.9	4.4	3.8	4.1	3.6	3.2	2.8
20	5.7	5.2	4.7	4.1	3.6	3.9	3.5	3.0	2.6
21	5.4	4.9	4.4	3.9	3.5	3.7	3.3	2.9	2.5
22	5.2	4.7	4.2	3.8	3.3	3.6	3.2	2.7	2.4
23	4.9	4.5	4.0	3.6	3.2	3.4	3.0	2.6	2.3
24	4.7	4.3	3.9	3.5	3.0	3.3	2.9	2.5	2.2
25	4.5	4.1	3.7	3.3	2.9	3.1	2.8	2.4	2.1

Span in Feet	5" C NO. 120			4" C NO. 118			3" C NO. 116		
	11.5 lbs.	9.0 lbs.	6.7 lbs.	7.25 lbs.	6.25 lbs.	5.4 lbs.	6.0 lbs.	5.0 lbs.	4.1 lbs.
4	12.5	10.6	9.0	6.9	6.3	5.8	4.1	3.7	3.3
5	10.0	8.5	7.2	5.5	5.0	4.6	3.3	3.0	2.6
6	8.3	7.1	6.0	4.6	4.2	3.8	2.8	2.5	2.2
7	7.1	6.1	5.1	3.9	3.6	3.3	2.4	2.1	1.9
8	6.2	5.3	4.5	3.4	3.1	2.9	2.1	1.8	1.7
9	5.5	4.7	4.0	3.0	2.8	2.6	1.8	1.6	1.5
10	5.0	4.3	3.6	2.7	2.5	2.3	1.7	1.5	1.3
11	4.5	3.9	3.3	2.5	2.3	2.1	1.5	1.3	1.2
12	4.2	3.5	3.0	2.3	2.1	1.9	1.4	1.2	1.1
13	3.8	3.3	2.8	2.1	1.9	1.8	1.3	1.1	1.0
14	3.6	3.0	2.6	2.0	1.8	1.6	1.2	1.1	0.9
15	3.3	2.8	2.4	1.8	1.7	1.5	1.1	1.0	0.9

H COLUMNS AS BEAMS

ALLOWABLE UNIFORM LOADS IN THOUSANDS OF POUNDS

Maximum fiber stress, 18,000 pounds per square inch

Span in Feet	8" H NO. 297			6" H NO. 287		6" H NO. 286	
	37.7 lbs.	34.3 lbs.	32.6 lbs.	27.5 lbs.	25.0 lbs.	22.5 lbs.	20.0 lbs.
4	90.6			49.3		41.0	
5	72.5	69.3		39.4	37.6	32.8	31.0
6	60.4	57.8	56.4	32.9	31.4	27.4	25.9
7	51.8	49.5	48.4	28.2	26.9	23.4	22.2
8	45.3	43.3	42.3	24.6	23.5	20.5	19.4
9	40.3	38.5	37.6	21.9	20.9	18.2	17.2
10	36.2	34.7	33.8	19.7	18.8	16.4	15.5
11	32.9	31.5	30.8	17.9	17.1	14.9	14.1
12	30.2	28.8	28.2	16.4	15.7	13.7	12.9
13	27.6	26.4	26.0	15.2	14.5	12.6	11.9
14	25.9	24.8	24.2	14.1	13.4	11.7	11.1
15	24.2	23.1	22.6	13.1	12.5	10.9	10.3
16	22.7	21.6	21.2	12.3	11.8	10.2	9.7
17	21.3	20.4	19.9	11.6	11.1	9.6	9.1
18	20.1	19.2	18.8	11.0	10.4	9.1	8.6
19	19.1	18.2	17.8	10.4	9.9	8.6	8.2
20	18.1	17.3	16.9	9.9	9.4	8.2	7.8
21	17.3	16.5	16.1	9.4	9.0	7.8	7.4
22	16.5	15.8	15.4	9.0	8.6	7.4	7.0
23	15.8	15.1	14.7	8.6	8.2	7.1	6.8
24	15.1	14.5	14.1	8.2	7.8	6.8	6.5
25	14.5	13.9	13.5	7.9	7.5	6.6	6.2

ALLOWABLE CONCENTRIC LOADS IN THOUSANDS OF POUNDS FOR H COLUMNS. A.I.S.C. SPECIFICATIONS

Effective Length in Feet	8" H NO. 297			6" H NO. 287		6" H NO. 286	
	37.7 lbs.	34.3 lbs.	32.6 lbs.	27.5 lbs.	25.0 lbs.	22.5 lbs.	20.0 lbs.
4	165	150	143	121	110	99	88
6	165	150	143	121	110	99	88
8	165	150	143	116	106	93	83
9	165	150	143	110	100	88	79
10	160	146	140	104	95	83	75
11	154	141	135	98	90	78	70
12	147	136	130	92	84	73	66
13	141	130	124	87	79	69	62
14	135	124	119	81	75	64	58
15	129	119	114	76	70	60	55
16	123	114	109	72	66	56	51
17	117	108	104	67	62	53	48
18	112	103	100	63	58	50	45
19	106	99	95	59	55	46	42
20	101	94	91	56	51	44	40
22	92	85	83	49	46	38	35
24	83	78	75				
26	76	71	68				
28	69	64	62				
30	63	59	57				

Loads below the heavy horizontal lines are for secondary members only

ANGLES, EQUAL LEGS

Neutral Axis

ALLOWABLE UNIFORM LOADS IN THOUSANDS OF POUNDS
FOR ANGLES BRACED AGAINST LATERAL DEFLECTION
NEUTRAL AXIS PARALLEL TO EITHER LEG

Maximum fiber stress, 18,000 pounds per square inch

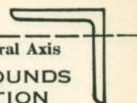

Span in Feet	8 X 8										
	1 1/8	1 1/16	1	15/16	7/8	13/16	3/4	11/16	5/8	9/16	1/2
2	105.2	100.0	94.8	89.5	84.1	78.6	73.1	67.5	61.8	56.0	50.2
3	70.1	66.7	63.2	59.6	56.1	52.4	48.7	45.0	41.2	37.4	33.5
4	52.6	50.0	47.4	44.7	42.0	39.3	36.6	33.8	30.9	28.0	25.1
5	42.1	40.0	37.9	35.8	33.6	31.5	29.2	27.0	24.7	22.4	20.1
6	35.1	33.3	31.6	29.8	28.0	26.2	24.4	22.5	20.6	18.7	16.7
7	30.1	28.6	27.1	25.6	24.0	22.5	20.9	19.3	17.7	16.0	14.3
8	26.3	25.0	23.7	22.4	21.0	19.7	18.3	16.9	15.5	14.0	12.5
9	23.4	22.2	21.1	19.9	18.7	17.5	16.2	15.0	13.7	12.5	11.2
10	21.0	20.0	19.0	17.9	16.8	15.7	14.6	13.5	12.4	11.2	10.0
11	19.1	18.2	17.2	16.3	15.3	14.3	13.3	12.3	11.2	10.2	9.1
12	17.5	16.7	15.8	14.9	14.0	13.1	12.2	11.2	10.3	9.3	8.4
13	16.2	15.4	14.6	13.8	12.9	12.1	11.2	10.4	9.5	8.6	7.7
14	15.0	14.3	13.5	12.8	12.0	11.2	10.4	9.6	8.8	8.0	7.2
15	14.0	13.3	12.6	11.9	11.2	10.5	9.7	9.0	8.2	7.5	6.7
16	13.1	12.5	11.8	11.2	10.5	9.8	9.1	8.4	7.7	7.0	6.3
17	12.4	11.8	11.2	10.5	9.9	9.3	8.6	7.9	7.3	6.6	5.9
18	11.7	11.1	10.5	9.9	9.3	8.7	8.1	7.5	6.9	6.2	5.6
19	11.1	10.5	10.0	9.4	8.9	8.3	7.7	7.1	6.5	5.9	5.3
20	10.5	10.0	9.5	8.9	8.4	7.9	7.3	6.8	6.2	5.6	5.0
21	10.0	9.5	9.0	8.5	8.0	7.5	7.0	6.4	5.9	5.3	4.8
22	9.6	9.1	8.6	8.1	7.6	7.1	6.6	6.1	5.6	5.1	4.6
23	9.1	8.7	8.2	7.8	7.3	6.8	6.4	5.9	5.4	4.9	4.4
24	8.8	8.3	7.9	7.5	7.0	6.6	6.1	5.6	5.2	4.7	4.2
25	8.4	8.0	7.6	7.2	6.7	6.3	5.8	5.4	4.9	4.5	4.0
26	8.1	7.7	7.3	6.9	6.5	6.0	5.6	5.2	4.8	4.3	3.9
27	7.8	7.4	7.0	6.6	6.2	5.8	5.4	5.0	4.6	4.2	3.7
28	7.5	7.1	6.8	6.4	6.0	5.6	5.2	4.8	4.4	4.0	3.6

Loads below the dotted line produce deflections exceeding 1/360 of the span

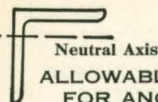

ANGLES, EQUAL LEGS

ALLOWABLE UNIFORM LOADS IN THOUSANDS OF POUNDS
FOR ANGLES BRACED AGAINST LATERAL DEFLECTION
NEUTRAL AXIS PARALLEL TO EITHER LEG

Maximum fiber stress, 18,000 pounds per square inch

Span in Feet	6 × 6											
	1 ¹ / ₁₆	1	1 ⁵ / ₁₆	7 ⁷ / ₈	1 ⁹ / ₁₆	3 ³ / ₄	1 ¹¹ / ₁₆	5 ⁵ / ₈	9 ⁹ / ₁₆	1 ¹ / ₂	7 ⁷ / ₁₆	3 ³ / ₈
2	54.2	51.4	48.6	45.8	42.9	40.0	37.0	33.9	30.8	27.7	24.5	21.2
3	36.1	34.3	32.4	30.5	28.6	26.7	24.7	22.6	20.6	18.5	16.3	14.1
4	27.1	25.7	24.3	22.9	21.5	20.0	18.5	17.0	15.4	13.8	12.2	10.6
5	21.7	20.6	19.5	18.3	17.2	16.0	14.8	13.6	12.3	11.1	9.8	8.5
6	18.1	17.1	16.2	15.3	14.3	13.3	12.3	11.3	10.3	9.2	8.2	7.1
7	15.5	14.7	13.9	13.1	12.3	11.4	10.6	9.7	8.8	7.9	7.0	6.0
8	13.5	12.9	12.2	11.5	10.7	10.0	9.2	8.5	7.7	6.9	6.1	5.3
9	12.0	11.4	10.8	10.2	9.5	8.9	8.2	7.5	6.9	6.2	5.4	4.7
10	10.8	10.3	9.7	9.2	8.6	8.0	7.4	6.8	6.2	5.5	4.9	4.2
11	9.9	9.4	8.8	8.3	7.8	7.3	6.7	6.2	5.6	5.0	4.4	3.8
12	9.0	8.6	8.1	7.6	7.2	6.7	6.2	5.7	5.1	4.6	4.1	3.5
13	8.3	7.9	7.5	7.0	6.6	6.2	5.7	5.2	4.7	4.3	3.8	3.3
14	7.7	7.3	6.9	6.5	6.1	5.7	5.3	4.8	4.4	4.0	3.5	3.0
15	7.2	6.9	6.5	6.1	5.7	5.3	4.9	4.5	4.1	3.7	3.3	2.8
16	6.8	6.4	6.1	5.7	5.4	5.0	4.6	4.2	3.9	3.5	3.1	2.6
17	6.4	6.1	5.7	5.4	5.0	4.7	4.4	4.0	3.6	3.3	2.9	2.5
18	6.0	5.7	5.4	5.1	4.8	4.4	4.1	3.8	3.4	3.1	2.7	2.4
19	5.7	5.4	5.1	4.8	4.5	4.2	3.9	3.6	3.2	2.9	2.6	2.2
20	5.4	5.1	4.9	4.6	4.3	4.0	3.7	3.4	3.1	2.8	2.4	2.1
21	5.2	4.9	4.6	4.4	4.1	3.8	3.5	3.2	2.9	2.6	2.3	2.0
22	4.9	4.7	4.4	4.2	3.9	3.6	3.4	3.1	2.8	2.5	2.2	1.9

Loads below the dotted line produce deflections exceeding 1/360 of the span

ANGLES, EQUAL LEGS

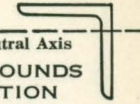
 Neutral Axis

**ALLOWABLE UNIFORM LOADS IN THOUSANDS OF POUNDS
FOR ANGLES BRACED AGAINST LATERAL DEFLECTION
NEUTRAL AXIS PARALLEL TO EITHER LEG**

Maximum fiber stress, 18,000 pounds per square inch

Span in Feet	5 × 5										
	1	$\frac{13}{16}$	$\frac{3}{4}$	$\frac{13}{16}$	$\frac{3}{4}$	$\frac{11}{16}$	$\frac{5}{8}$	$\frac{9}{16}$	$\frac{1}{2}$	$\frac{7}{16}$	$\frac{3}{8}$
2	34.8	32.9	31.0	29.1	27.2	25.2	23.1	21.1	18.9	16.8	14.5
3	23.2	21.9	20.7	19.4	18.1	16.8	15.4	14.0	12.6	11.2	9.7
4	17.4	16.5	15.5	14.6	13.6	12.6	11.6	10.5	9.5	8.4	7.3
5	13.9	13.2	12.4	11.7	10.9	10.1	9.3	8.4	7.6	6.7	5.8
6	11.6	11.0	10.3	9.7	9.1	8.4	7.7	7.0	6.3	5.5	4.8
7	9.9	9.4	8.9	8.3	7.8	7.2	6.6	6.0	5.4	4.8	4.2
8	8.7	8.2	7.8	7.3	6.8	6.3	5.8	5.3	4.7	4.2	3.6
9	7.7	7.3	6.9	6.5	6.0	5.6	5.1	4.7	4.2	3.7	3.2
10	7.0	6.6	6.2	5.8	5.4	5.0	4.6	4.2	3.8	3.4	2.9
11	6.3	6.0	5.6	5.3	4.9	4.6	4.2	3.8	3.4	3.0	2.6
12	5.8	5.5	5.2	4.9	4.5	4.2	3.9	3.5	3.2	2.8	2.4
13	5.3	5.1	4.8	4.5	4.2	3.9	3.6	3.2	2.9	2.6	2.2
14	5.0	4.7	4.4	4.2	3.9	3.6	3.3	3.0	2.7	2.4	2.1
15	4.6	4.4	4.1	3.9	3.6	3.4	3.1	2.8	2.5	2.2	1.9
16	4.3	4.1	3.9	3.6	3.4	3.1	2.9	2.6	2.4	2.1	1.8

Span in Feet	4 × 4										
	$\frac{13}{16}$	$\frac{3}{4}$	$\frac{11}{16}$	$\frac{5}{8}$	$\frac{9}{16}$	$\frac{1}{2}$	$\frac{7}{16}$	$\frac{3}{8}$	$\frac{5}{16}$	$\frac{1}{4}$	
2	18.0	16.9	15.7	14.4	13.1	11.8	10.5	9.1	7.7	6.3	
3	12.0	11.2	10.4	9.6	8.8	7.9	7.0	6.1	5.2	4.2	
4	9.0	8.4	7.8	7.2	6.6	5.9	5.3	4.6	3.9	3.1	
5	7.2	6.7	6.3	5.8	5.3	4.7	4.2	3.7	3.1	2.5	
6	6.0	5.6	5.2	4.8	4.4	3.9	3.5	3.0	2.6	2.1	
7	5.2	4.8	4.5	4.1	3.8	3.4	3.0	2.6	2.2	1.8	
8	4.5	4.2	3.9	3.6	3.3	3.0	2.6	2.3	1.9	1.6	
9	4.0	3.7	3.5	3.2	2.9	2.6	2.3	2.0	1.7	1.4	
10	3.6	2.4	3.1	2.9	2.6	2.4	2.1	1.8	1.5	1.3	
11	3.3	3.1	2.8	2.6	2.4	2.2	1.9	1.7	1.4	1.1	
12	3.0	2.8	2.6	2.4	2.2	2.0	1.8	1.5	1.3	1.0	
13	2.8	2.6	2.4	2.2	2.0	1.8	1.6	1.4	1.2	.96	

Loads below the dotted line produce deflections exceeding 1/360 of the span

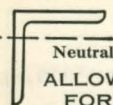

Neutral Axis

ANGLES, EQUAL LEGS

**ALLOWABLE UNIFORM LOADS IN THOUSANDS OF POUNDS
FOR ANGLES BRACED AGAINST LATERAL DEFLECTION
NEUTRAL AXIS PARALLEL TO EITHER LEG**

Maximum fiber stress, 18,000 pounds per square inch

Span in Feet	$3\frac{1}{2} \times 3\frac{1}{2}$									
	$\frac{13}{16}$	$\frac{3}{4}$	$\frac{11}{16}$	$\frac{5}{8}$	$\frac{9}{16}$	$\frac{1}{2}$	$\frac{7}{16}$	$\frac{3}{8}$	$\frac{5}{16}$	$\frac{1}{4}$
2	13.5	12.6	11.7	10.8	9.9	8.9	7.9	6.9	5.9	4.8
3	9.0	8.4	7.8	7.2	6.6	6.0	5.3	4.6	3.9	3.2
4	6.8	6.3	5.9	5.4	4.9	4.5	4.0	3.5	2.9	2.4
5	5.4	5.1	4.7	4.3	4.0	3.6	3.2	2.8	2.3	1.9
6	4.5	4.2	3.9	3.6	3.3	3.0	2.6	2.3	2.0	1.6
7	3.9	3.6	3.4	3.1	2.8	2.6	2.3	2.0	1.7	1.4
8	3.4	3.2	2.9	2.7	2.5	2.2	2.0	1.7	1.5	1.2
9	3.0	2.8	2.6	2.4	2.2	2.0	1.8	1.5	1.3	1.1
10	2.7	2.5	2.3	2.2	2.0	1.8	1.6	1.4	1.2	.95
11	2.5	2.3	2.1	2.0	1.8	1.6	1.4	1.3	1.1	.87
12	2.3	2.1	2.0	1.8	1.6	1.5	1.3	1.2	.98	.79

Span in Feet	3×3						
	$\frac{5}{8}$	$\frac{9}{16}$	$\frac{1}{2}$	$\frac{7}{16}$	$\frac{3}{8}$	$\frac{5}{16}$	$\frac{1}{4}$
2	7.8	7.1	6.4	5.7	5.0	4.2	3.5
3	5.2	4.7	4.3	3.8	3.3	2.8	2.3
4	3.9	3.6	3.2	2.9	2.5	2.1	1.7
5	3.1	2.8	2.6	2.3	2.0	1.7	1.4
6	2.6	2.4	2.1	1.9	1.7	1.4	1.2
7	2.2	2.0	1.8	1.6	1.4	1.2	.99
8	1.9	1.8	1.6	1.4	1.2	1.1	.87
9	1.7	1.6	1.4	1.3	1.1	.94	.77
10	1.6	1.4	1.3	1.1	1.0	.85	.69
11	1.4	1.3	1.2	1.0	.91	.77	.63

Loads below the dotted line produce deflections exceeding 1/360 of the span

ANGLES, EQUAL LEGS



 Neutral Axis

**ALLOWABLE UNIFORM LOADS IN THOUSANDS OF POUNDS
FOR ANGLES BRACED AGAINST LATERAL DEFLECTION
NEUTRAL AXIS PARALLEL TO EITHER LEG**

Maximum fiber stress, 18,000 pounds per square inch

Span in Feet	$2\frac{1}{2} \times 2\frac{1}{2}$						
	$\frac{1}{2}$	$\frac{7}{16}$	$\frac{3}{8}$	$\frac{5}{16}$	$\frac{1}{4}$	$\frac{3}{16}$	$\frac{1}{8}$
2	4.3	3.9	3.4	2.9	2.4	1.8	1.2
3	2.9	2.6	2.3	1.9	1.6	1.2	.83
4	2.2	1.9	1.7	1.4	1.2	.91	.62
5	1.7	1.6	1.4	1.2	.95	.73	.50
6	1.4	1.3	1.1	.96	.79	.61	.41
7	1.2	1.1	.97	.83	.68	.52	.35
8	1.1	.97	.85	.72	.59	.45	.31
Span in Feet	2×2						
	$\frac{7}{16}$	$\frac{3}{8}$	$\frac{5}{16}$	$\frac{1}{4}$	$\frac{3}{16}$	$\frac{1}{8}$	
2	2.4	2.1	1.8	1.5	1.1	.78	
3	1.6	1.4	1.2	.99	.76	.52	
4	1.2	1.1	.90	.74	.57	.39	
5	.96	.84	.72	.59	.46	.31	
6	.80	.70	.60	.49	.38	.26	
7	.69	.60	.51	.42	.33	.22	

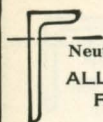
Loads below the dotted line produce deflections exceeding 1/360 of the span



ANGLES, UNEQUAL LEGS

ALLOWABLE UNIFORM LOADS IN THOUSANDS OF POUNDS
FOR ANGLES BRACED AGAINST LATERAL DEFLECTION
NEUTRAL AXIS PARALLEL TO SHORTER LEG

Maximum fiber stress, 18,000 pounds per square inch

Span in Feet	8 × 6									
	1	$\frac{15}{16}$	$\frac{7}{8}$	$\frac{13}{16}$	$\frac{3}{4}$	$\frac{11}{16}$	$\frac{5}{8}$	$\frac{9}{16}$	$\frac{1}{2}$	$\frac{7}{16}$
2	90.7	85.6	80.5	75.3	70.0	64.6	59.2	53.7	48.1	42.4
3	60.4	57.1	53.7	50.2	46.7	43.1	39.5	35.8	32.1	28.3
4	45.3	42.8	40.2	37.6	35.0	32.3	29.6	26.8	24.0	21.2
5	36.3	34.2	32.2	30.1	28.0	25.9	23.7	21.5	19.2	17.0
6	30.2	28.5	26.8	25.1	23.3	21.5	19.7	17.9	16.0	14.1
7	25.9	24.5	23.0	21.5	20.0	18.5	16.9	15.3	13.7	12.1
8	22.7	21.4	20.1	18.8	17.5	16.2	14.8	13.4	12.0	10.6
9	20.1	19.0	17.9	16.7	15.6	14.4	13.2	11.9	10.7	9.4
10	18.1	17.1	16.1	15.1	14.0	12.9	11.8	10.7	9.6	8.5
11	16.5	15.6	14.6	13.7	12.7	11.8	10.8	9.8	8.7	7.7
12	15.1	14.3	13.4	12.5	11.7	10.8	9.9	8.9	8.0	7.1
13	13.9	13.2	12.4	11.6	10.8	9.9	9.1	8.3	7.4	6.5
14	13.0	12.2	11.5	10.8	10.0	9.2	8.5	7.7	6.9	6.1
15	12.1	11.4	10.7	10.0	9.3	8.6	7.9	7.2	6.4	5.7
16	11.3	10.7	10.1	9.4	8.8	8.1	7.4	6.7	6.0	5.3
17	10.7	10.1	9.5	8.9	8.2	7.6	7.0	6.3	5.7	5.0
18	10.1	9.5	8.9	8.4	7.8	7.2	6.6	6.0	5.3	4.7
19	9.5	9.0	8.5	7.9	7.4	6.8	6.2	5.7	5.1	4.5
20	9.1	8.6	8.0	7.5	7.0	6.5	5.9	5.4	4.8	4.2
21	8.6	8.2	7.7	7.2	6.7	6.2	5.6	5.1	4.6	4.0
22	8.2	7.8	7.3	6.8	6.4	5.9	5.4	4.9	4.4	3.9
23	7.9	7.4	7.0	6.5	6.1	5.6	5.1	4.7	4.2	3.7
24	7.6	7.1	6.7	6.3	5.8	5.4	4.9	4.5	4.0	3.5
25	7.3	6.8	6.4	6.0	5.6	5.2	4.7	4.3	3.8	3.4
26	7.0	6.6	6.2	5.8	5.4	5.0	4.6	4.1	3.7	3.3
27	6.7	6.3	6.0	5.6	5.2	4.8	4.4	4.0	3.6	3.1

Loads below the dotted line produce deflections exceeding 1/360 of the span

ANGLES, UNEQUAL LEGS

Neutral Axis

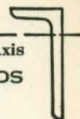

ALLOWABLE UNIFORM LOADS IN THOUSANDS OF POUNDS
FOR ANGLES BRACED AGAINST LATERAL DEFLECTION
NEUTRAL AXIS PARALLEL TO SHORTER LEG

Maximum fiber stress, 18,000 pounds per square inch

Span in Feet	8 × 3½									
	1	1⅝	⅞	1⅜	¾	1⅛	⅝	⅞	½	⅜
2	82.2	77.7	73.1	68.4	63.6	58.8	53.9	48.9	43.8	38.7
3	54.8	51.8	48.7	45.6	42.4	39.2	35.9	32.6	29.2	25.8
4	41.1	38.8	36.5	34.2	31.8	29.4	27.0	24.5	21.9	19.3
5	32.9	31.1	29.2	27.4	25.5	23.5	21.6	19.6	17.5	15.5
6	27.4	25.9	24.4	22.8	21.2	19.6	18.0	16.3	14.6	12.9
7	23.5	22.2	20.9	19.5	18.2	16.8	15.4	14.0	12.5	11.1
8	20.5	19.4	18.3	17.1	15.9	14.7	13.5	12.2	11.0	9.7
9	18.3	17.3	16.2	15.2	14.1	13.1	12.0	10.9	9.7	8.6
10	16.4	15.5	14.6	13.7	12.7	11.8	10.8	9.8	8.8	7.7
11	14.9	14.1	13.3	12.4	11.6	10.7	9.8	8.9	8.0	7.0
12	13.7	12.9	12.2	11.4	10.6	9.8	9.0	8.2	7.3	6.4
13	12.6	12.0	11.2	10.5	9.8	9.0	8.3	7.5	6.7	6.0
14	11.7	11.1	10.4	9.8	9.1	8.4	7.7	7.0	6.3	5.5
15	11.0	10.4	9.7	9.1	8.5	7.8	7.2	6.5	5.8	5.2
16	10.3	9.7	9.1	8.5	8.0	7.4	6.7	6.1	5.5	4.8
17	9.7	9.1	8.6	8.0	7.5	6.9	6.3	5.8	5.2	4.6
18	9.1	8.6	8.1	7.6	7.1	6.5	6.0	5.4	4.9	4.3
19	8.7	8.2	7.7	7.2	6.7	6.2	5.7	5.1	4.6	4.1
20	8.2	7.8	7.3	6.8	6.4	5.9	5.4	4.9	4.4	3.9
21	7.8	7.4	7.0	6.5	6.1	5.6	5.1	4.7	4.2	3.7
22	7.5	7.1	6.6	6.2	5.8	5.3	4.9	4.4	4.0	3.5
23	7.1	6.8	6.4	5.9	5.5	5.1	4.7	4.3	3.8	3.4
24	6.8	6.5	6.1	5.7	5.3	4.9	4.5	4.1	3.7	3.2
25	6.6	6.2	5.8	5.5	5.1	4.7	4.3	3.9	3.5	3.1

Loads below the dotted line produce deflections exceeding 1/360 of the span

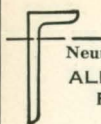

ANGLES, UNEQUAL LEGS

Neutral Axis

ALLOWABLE UNIFORM LOADS IN THOUSANDS OF POUNDS
FOR ANGLES BRACED AGAINST LATERAL DEFLECTION
NEUTRAL AXIS PARALLEL TO SHORTER LEG

Maximum fiber stress, 18,000 pounds per square inch

Span in Feet	7 × 3½										
	1	1⅛	7⁄8	13⁄16	3⁄4	11⁄16	5⁄8	9⁄16	1⁄2	7⁄16	3⁄8
2	63.5	60.0	56.5	52.9	49.3	45.6	41.8	38.0	34.1	30.1	26.0
3	42.3	40.0	37.7	35.3	32.9	30.4	27.9	25.3	22.7	20.1	17.4
4	31.7	30.0	28.3	26.5	24.6	22.8	20.9	19.0	17.0	15.0	13.0
5	25.4	24.0	22.6	21.2	19.7	18.2	16.7	15.2	13.6	12.0	10.4
6	21.2	20.0	18.8	17.6	16.4	15.2	13.9	12.7	11.4	10.0	8.7
7	18.1	17.1	16.1	15.1	14.1	13.0	11.9	10.9	9.7	8.6	7.4
8	15.9	15.0	14.1	13.2	12.3	11.4	10.5	9.5	8.5	7.5	6.5
9	14.1	13.3	12.6	11.8	11.0	10.1	9.3	8.4	7.6	6.7	5.8
10	12.7	12.0	11.3	10.6	9.9	9.1	8.4	7.6	6.8	6.0	5.2
11	11.5	10.9	10.3	9.6	9.0	8.3	7.6	6.9	6.2	5.5	4.7
12	10.6	10.0	9.4	8.8	8.2	7.6	7.0	6.3	5.7	5.0	4.3
13	9.8	9.2	8.7	8.1	7.6	7.0	6.4	5.8	5.2	4.6	4.0
14	9.1	8.6	8.1	7.6	7.0	6.5	6.0	5.4	4.9	4.3	3.7
15	8.5	8.0	7.5	7.1	6.6	6.1	5.6	5.1	4.5	4.0	3.5
16	7.9	7.5	7.1	6.6	6.2	5.7	5.2	4.7	4.3	3.8	3.3
17	7.5	7.1	6.6	6.2	5.8	5.4	4.9	4.5	4.0	3.5	3.1
18	7.1	6.7	6.3	5.9	5.5	5.1	4.6	4.2	3.8	3.3	2.9
19	6.7	6.3	5.9	5.6	5.2	4.8	4.4	4.0	3.6	3.2	2.7
20	6.3	6.0	5.7	5.3	4.9	4.6	4.2	3.8	3.4	3.0	2.6
21	6.0	5.7	5.4	5.0	4.7	4.3	4.0	3.6	3.2	2.9	2.5
22	5.8	5.5	5.1	4.8	4.5	4.1	3.8	3.5	3.1	2.7	2.4

Loads below the dotted line produce deflections exceeding 1/360 of the span

ANGLES, UNEQUAL LEGS

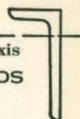
 Neutral Axis

ALLOWABLE UNIFORM LOADS IN THOUSANDS OF POUNDS
FOR ANGLES BRACED AGAINST LATERAL DEFLECTION
NEUTRAL AXIS PARALLEL TO SHORTER LEG

Maximum fiber stress, 18,000 pounds per square inch

Span in Feet	6 × 4											
	1	1 ⁵ / ₁₆	3 ⁸ / ₁₆	1 ³ / ₁₆	3 ⁴ / ₁₆	1 ¹ / ₁₆	5 ⁸ / ₁₆	9 ¹⁶ / ₁₆	1 ¹ / ₂	7 ¹⁶ / ₁₆	3 ⁸ / ₁₆	
2	48.1	45.5	42.9	40.2	37.5	34.7	31.9	29.0	26.0	23.0	19.9	
3	32.1	30.4	28.6	26.8	25.0	23.1	21.2	19.3	17.3	15.3	13.3	
4	24.1	22.8	21.5	20.1	18.7	17.4	15.9	14.5	13.0	11.5	10.0	
5	19.3	18.2	17.2	16.1	15.0	13.9	12.7	11.6	10.4	9.2	8.0	
6	16.0	15.2	14.3	13.4	12.5	11.6	10.6	9.7	8.7	7.7	6.6	
7	13.8	13.0	12.3	11.5	10.7	9.9	9.1	8.3	7.4	6.6	5.7	
8	12.0	11.4	10.7	10.1	9.4	8.7	8.0	7.2	6.5	5.7	5.0	
9	10.7	10.1	9.5	8.9	8.3	7.7	7.1	6.4	5.8	5.1	4.4	
10	9.6	9.1	8.6	8.0	7.5	6.9	6.4	5.8	5.2	4.6	4.0	
11	8.8	8.3	7.8	7.3	6.8	6.3	5.8	5.3	4.7	4.2	3.6	
12	8.0	7.6	7.2	6.7	6.2	5.8	5.3	4.8	4.3	3.8	3.3	
13	7.4	7.0	6.6	6.2	5.8	5.3	4.9	4.5	4.0	3.5	3.1	
14	6.9	6.5	6.1	5.7	5.4	5.0	4.6	4.1	3.7	3.3	2.8	
15	6.4	6.1	5.7	5.4	5.0	4.6	4.2	3.9	3.5	3.1	2.7	

Span in Feet	6 × 3 ¹ / ₂											
	1	1 ⁵ / ₁₆	3 ⁸ / ₁₆	1 ³ / ₁₆	3 ⁴ / ₁₆	1 ¹ / ₁₆	5 ⁸ / ₁₆	9 ¹⁶ / ₁₆	1 ¹ / ₂	7 ¹⁶ / ₁₆	3 ⁸ / ₁₆	5 ¹⁶ / ₁₆
2	47.0	44.5	41.9	39.3	36.6	33.9	31.1	28.3	25.4	22.5	19.5	16.4
3	31.3	29.6	27.9	26.2	24.4	22.6	20.8	18.9	16.9	15.0	13.0	10.9
4	23.5	22.2	20.9	19.6	18.3	17.0	15.6	14.2	12.7	11.2	9.7	8.2
5	18.8	17.8	16.8	15.7	14.6	13.6	12.5	11.3	10.2	9.0	7.8	6.6
6	15.7	14.8	14.0	13.1	12.2	11.3	10.4	9.4	8.5	7.5	6.5	5.5
7	13.4	12.7	12.0	11.2	10.5	9.7	8.9	8.1	7.3	6.4	5.6	4.7
8	11.7	11.1	10.5	9.8	9.2	8.5	7.8	7.1	6.4	5.6	4.9	4.1
9	10.4	9.9	9.3	8.7	8.1	7.5	6.9	6.3	5.6	5.0	4.3	3.6
10	9.4	8.9	8.4	7.9	7.3	6.8	6.2	5.7	5.1	4.5	3.9	3.3
11	8.5	8.1	7.6	7.1	6.7	6.2	5.7	5.1	4.6	4.1	3.5	3.0
12	7.8	7.4	7.0	6.5	6.1	5.6	5.2	4.7	4.2	3.7	3.2	2.7
13	7.2	6.8	6.4	6.0	5.6	5.2	4.8	4.4	3.9	3.5	3.0	2.5
14	6.7	6.4	6.0	5.6	5.2	4.8	4.4	4.0	3.6	3.2	2.8	2.3

Loads below the dotted line produce deflections exceeding 1/360 of the span

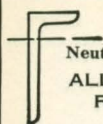

Neutral Axis

ANGLES, UNEQUAL LEGS

ALLOWABLE UNIFORM LOADS IN THOUSANDS OF POUNDS
FOR ANGLES BRACED AGAINST LATERAL DEFLECTION
NEUTRAL AXIS PARALLEL TO SHORTER LEG

Maximum fiber stress, 18,000 pounds per square inch

Span in Feet	5 × 4									
	$\frac{3}{8}$	$\frac{13}{16}$	$\frac{3}{4}$	$\frac{11}{16}$	$\frac{5}{8}$	$\frac{9}{16}$	$\frac{1}{2}$	$\frac{7}{16}$	$\frac{3}{8}$	$\frac{5}{16}$
2	30.0	28.1	26.3	24.3	22.4	20.4	18.3	16.2	14.1	11.9
3	20.0	18.8	17.5	16.2	14.9	13.6	12.2	10.8	9.4	7.9
4	15.0	14.1	13.1	12.2	11.2	10.2	9.2	8.1	7.0	5.9
5	12.0	11.3	10.5	9.7	9.0	8.1	7.3	6.5	5.6	4.7
6	10.0	9.4	8.8	8.1	7.5	6.8	6.1	5.4	4.7	4.0
7	8.6	8.0	7.5	7.0	6.4	5.8	5.2	4.6	4.0	3.4
8	7.5	7.0	6.6	6.1	5.6	5.1	4.6	4.1	3.5	3.0
9	6.7	6.3	5.8	5.4	5.0	4.5	4.1	3.6	3.1	2.6
10	6.0	5.6	5.3	4.9	4.5	4.1	3.7	3.2	2.8	2.4
11	5.5	5.1	4.8	4.4	4.1	3.7	3.3	3.0	2.6	2.2
12	5.0	4.7	4.4	4.1	3.7	3.4	3.1	2.7	2.3	2.0
13	4.6	4.3	4.0	3.7	3.4	3.1	2.8	2.5	2.2	1.8
14	4.3	4.0	3.8	3.5	3.2	2.9	2.6	2.3	2.0	1.7
Span in Feet	5 × 3½									
	$\frac{3}{8}$	$\frac{13}{16}$	$\frac{3}{4}$	$\frac{11}{16}$	$\frac{5}{8}$	$\frac{9}{16}$	$\frac{1}{2}$	$\frac{7}{16}$	$\frac{3}{8}$	$\frac{5}{16}$
2	29.3	27.5	25.7	23.8	21.9	19.9	17.9	15.9	13.8	11.6
3	19.5	18.3	17.1	15.9	14.6	13.3	11.9	10.6	9.2	7.7
4	14.6	13.7	12.8	11.9	10.9	10.0	9.0	7.9	6.9	5.8
5	11.7	11.0	10.3	9.5	8.8	8.0	7.2	6.3	5.5	4.6
6	9.8	9.2	8.6	7.9	7.3	6.6	6.0	5.3	4.6	3.9
7	8.4	7.9	7.3	6.8	6.3	5.7	5.1	4.5	3.9	3.3
8	7.3	6.9	6.4	5.9	5.5	5.0	4.5	4.0	3.4	2.9
9	6.5	6.1	5.7	5.3	4.9	4.4	4.0	3.5	3.1	2.6
10	5.9	5.5	5.1	4.8	4.4	4.0	3.6	3.2	2.8	2.3
11	5.3	5.0	4.7	4.3	4.0	3.6	3.3	2.9	2.5	2.1
12	4.9	4.6	4.3	4.0	3.6	3.3	3.0	2.6	2.3	1.9
13	4.5	4.2	3.9	3.7	3.4	3.1	2.8	2.4	2.1	1.8
14	4.2	3.9	3.7	3.4	3.1	2.8	2.6	2.3	2.0	1.7

Loads below the dotted line produce deflections exceeding 1/360 of the span

ANGLES, UNEQUAL LEGS

 Neutral Axis

ALLOWABLE UNIFORM LOADS IN THOUSANDS OF POUNDS
FOR ANGLES BRACED AGAINST LATERAL DEFLECTION
NEUTRAL AXIS PARALLEL TO SHORTER LEG

Maximum fiber stress, 18,000 pounds per square inch

Span in Feet	5 × 3								
	$\frac{13}{16}$	$\frac{3}{4}$	$\frac{11}{16}$	$\frac{5}{8}$	$\frac{9}{16}$	$\frac{1}{2}$	$\frac{7}{16}$	$\frac{3}{8}$	$\frac{5}{16}$
2	26.7	25.0	23.2	21.3	19.4	17.5	15.5	13.4	11.3
3	17.8	16.6	15.4	14.2	12.9	11.6	10.3	8.9	7.5
4	13.4	12.5	11.6	10.6	9.7	8.7	7.7	6.7	5.7
5	10.7	10.0	9.3	8.5	7.8	7.0	6.2	5.4	4.5
6	8.9	8.3	7.7	7.1	6.5	5.8	5.2	4.5	3.8
7	7.6	7.1	6.6	6.1	5.5	5.0	4.4	3.8	3.2
8	6.7	6.2	5.8	5.3	4.9	4.4	3.9	3.4	2.8
9	5.9	5.5	5.1	4.7	4.3	3.9	3.4	3.0	2.5
10	5.3	5.0	4.6	4.3	3.9	3.5	3.1	2.7	2.3
11	4.9	4.5	4.2	3.9	3.5	3.2	2.8	2.4	2.1
12	4.5	4.2	3.9	3.5	3.2	2.9	2.6	2.2	1.9
13	4.1	3.8	3.6	3.3	3.0	2.7	2.4	2.1	1.7
14	3.8	3.6	3.3	3.0	2.8	2.5	2.2	1.9	1.6
15	3.6	3.3	3.1	2.8	2.6	2.3	2.1	1.8	1.5
16	3.3	3.1	2.9	2.7	2.4	2.2	1.9	1.7	1.4

Span in Feet	4 × 3½								
	$\frac{13}{16}$	$\frac{3}{4}$	$\frac{11}{16}$	$\frac{5}{8}$	$\frac{9}{16}$	$\frac{1}{2}$	$\frac{7}{16}$	$\frac{3}{8}$	$\frac{5}{16}$
2	17.7	16.5	15.3	14.1	12.9	11.6	10.3	9.0	7.6
3	11.8	11.0	10.2	9.4	8.6	7.7	6.9	6.0	5.1
4	8.8	8.3	7.7	7.1	6.4	5.8	5.2	4.5	3.8
5	7.1	6.6	6.1	5.6	5.2	4.6	4.1	3.6	3.0
6	5.9	5.5	5.1	4.7	4.3	3.9	3.4	3.0	2.5
7	5.0	4.7	4.4	4.0	3.7	3.3	2.9	2.6	2.2
8	4.4	4.1	3.8	3.5	3.2	2.9	2.6	2.2	1.9
9	3.9	3.7	3.4	3.1	2.9	2.6	2.3	2.0	1.7
10	3.5	3.3	3.1	2.8	2.6	2.3	2.1	1.8	1.5
11	3.2	3.0	2.8	2.6	2.3	2.1	1.9	1.6	1.4
12	2.9	2.8	2.6	2.4	2.1	1.9	1.7	1.5	1.3
13	2.7	2.5	2.4	2.2	2.0	1.8	1.6	1.4	1.2

Loads below the dotted line produce deflections exceeding 1/360 of the span

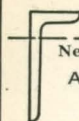

Neutral Axis

ANGLES, UNEQUAL LEGS

ALLOWABLE UNIFORM LOADS IN THOUSANDS OF POUNDS
FOR ANGLES BRACED AGAINST LATERAL DEFLECTION
NEUTRAL AXIS PARALLEL TO SHORTER LEG

Maximum fiber stress, 18,000 pounds per square inch

Span in Feet	4 × 3									
	$\frac{13}{16}$	$\frac{3}{4}$	$\frac{11}{16}$	$\frac{5}{8}$	$\frac{9}{16}$	$\frac{1}{2}$	$\frac{7}{16}$	$\frac{3}{8}$	$\frac{5}{16}$	$\frac{1}{4}$
2	17.2	16.1	14.9	13.8	12.6	11.3	10.1	8.8	7.4	6.0
3	11.5	10.7	10.0	9.2	8.4	7.6	6.7	5.8	4.9	4.0
4	8.6	8.0	7.5	6.9	6.3	5.7	5.0	4.4	3.7	3.0
5	6.9	6.4	6.0	5.5	5.0	4.5	4.0	3.5	3.0	2.4
6	5.7	5.4	5.0	4.6	4.2	3.8	3.4	2.9	2.5	2.0
7	4.9	4.6	4.3	3.9	3.6	3.2	2.9	2.5	2.1	1.7
8	4.3	4.0	3.7	3.4	3.1	2.8	2.5	2.2	1.9	1.5
9	3.8	3.6	3.3	3.1	2.8	2.5	2.2	1.9	1.6	1.3
10	3.4	3.2	3.0	2.8	2.5	2.3	2.0	1.8	1.5	1.2
11	3.1	2.9	2.7	2.5	2.3	2.1	1.8	1.6	1.3	1.1
12	2.9	2.7	2.5	2.3	2.1	1.9	1.7	1.5	1.2	1.0
13	2.6	2.5	2.3	2.1	1.9	1.7	1.5	1.3	1.1	.92
Span in Feet	$3\frac{1}{2} \times 3$									
	$\frac{13}{16}$	$\frac{3}{4}$	$\frac{11}{16}$	$\frac{5}{8}$	$\frac{9}{16}$	$\frac{1}{2}$	$\frac{7}{16}$	$\frac{3}{8}$	$\frac{5}{16}$	$\frac{1}{4}$
2	13.2	12.3	11.5	10.6	9.7	8.7	7.6	6.8	5.7	4.7
3	8.8	8.2	7.6	7.1	6.4	5.8	5.0	4.5	3.8	3.1
4	6.6	6.2	5.7	5.3	4.8	4.4	3.8	3.4	2.9	2.3
5	5.3	4.9	4.6	4.2	3.9	3.5	3.0	2.7	2.3	1.9
6	4.4	4.1	3.8	3.5	3.2	2.9	2.5	2.3	1.9	1.6
7	3.8	3.5	3.3	3.0	2.8	2.5	2.2	1.9	1.6	1.3
8	3.3	3.1	2.9	2.6	2.4	2.2	1.9	1.7	1.4	1.2
9	2.9	2.7	2.5	2.4	2.1	1.9	1.7	1.5	1.3	1.0
10	2.6	2.5	2.3	2.1	1.9	1.7	1.5	1.4	1.1	.93
11	2.4	2.2	2.1	1.9	1.8	1.6	1.4	1.2	1.0	.85
12	2.2	2.1	1.9	1.8	1.6	1.5	1.3	1.1	.95	.78

Loads below the dotted line produce deflections exceeding $1/360$ of the span

ANGLES, UNEQUAL LEGS

Neutral Axis

ALLOWABLE UNIFORM LOADS IN THOUSANDS OF POUNDS
FOR ANGLES BRACED AGAINST LATERAL DEFLECTION
NEUTRAL AXIS PARALLEL TO SHORTER LEG

Maximum fiber stress, 18,000 pounds per square inch



Span in Feet	$3\frac{1}{2} \times 2\frac{1}{2}$							
	$\frac{1}{16}$	$\frac{5}{8}$	$\frac{9}{16}$	$\frac{1}{2}$	$\frac{7}{16}$	$\frac{3}{8}$	$\frac{5}{16}$	$\frac{1}{4}$
2	11.1	10.3	9.4	8.5	7.5	6.6	5.6	4.5
3	7.4	6.8	6.2	5.6	5.0	4.4	3.7	3.0
4	5.6	5.1	4.7	4.2	3.8	3.3	2.8	2.3
5	4.4	4.1	3.7	3.4	3.0	2.6	2.2	1.8
6	3.7	3.4	3.1	2.8	2.5	2.2	1.9	1.5
7	3.2	2.9	2.7	2.4	2.2	1.9	1.6	1.3
8	2.8	2.6	2.3	2.1	1.9	1.6	1.4	1.1
9	2.5	2.3	2.1	1.9	1.7	1.5	1.2	1.0
10	2.2	2.1	1.9	1.7	1.5	1.3	1.1	.91
11	2.0	1.9	1.7	1.5	1.4	1.2	1.0	.82

Span in Feet	$3 \times 2\frac{1}{2}$					
	$\frac{5}{16}$	$\frac{1}{2}$	$\frac{7}{16}$	$\frac{3}{8}$	$\frac{5}{16}$	$\frac{1}{4}$
2	6.9	6.3	5.6	4.9	4.1	3.4
3	4.6	4.2	3.7	3.2	2.8	2.2
4	3.5	3.1	2.8	2.4	2.1	1.7
5	2.8	2.5	2.2	1.9	1.7	1.3
6	2.3	2.1	1.9	1.6	1.4	1.1
7	2.0	1.8	1.6	1.4	1.2	.96
8	1.7	1.6	1.4	1.2	1.0	.84
9	1.5	1.4	1.2	1.1	.92	.75
10	1.4	1.3	1.1	.97	.83	.67

Loads below the dotted line produce deflections exceeding $1/360$ of the span

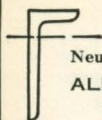

Neutral Axis

ANGLES, UNEQUAL LEGS

**ALLOWABLE UNIFORM LOADS IN THOUSANDS OF POUNDS
FOR ANGLES BRACED AGAINST LATERAL DEFLECTION
NEUTRAL AXIS PARALLEL TO SHORTER LEG**

Maximum fiber stress, 18,000 pounds per square inch

Span in Feet	3 × 2						
	½	⅙	⅜	⅓	¼	⅙	⅛
2	6.0	5.4	4.7	4.0	3.3		
3	4.0	3.6	3.1	2.7	2.2		
4	3.0	2.7	2.3	2.0	1.6		
5	2.4	2.1	1.9	1.6	1.3		
6	2.0	1.8	1.6	1.3	1.1		
7	1.7	1.5	1.3	1.1	.93		
8	1.5	1.3	1.2	1.0	.81		
9	1.3	1.2	1.0	.89	.72		
10	1.2	1.1	.94	.80	.65		

Span in Feet	2½ × 2						
	½	⅙	⅜	⅓	¼	⅙	⅛
2	4.2	3.7	3.3	2.8	2.3	1.8	1.2
3	2.8	2.5	2.2	1.9	1.5	1.2	.80
4	2.1	1.9	1.6	1.4	1.1	.88	.60
5	1.7	1.5	1.3	1.1	.92	.70	.48
6	1.4	1.2	1.1	.93	.76	.59	.40
7	1.2	1.1	.94	.80	.65	.50	.34
8	1.1	.94	.82	.70	.57	.44	.30

Loads below the dotted line produce deflections exceeding 1/360 of the span

ANGLES, UNEQUAL LEGS

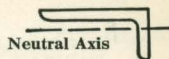

ALLOWABLE UNIFORM LOADS IN THOUSANDS OF POUNDS
FOR ANGLES BRACED AGAINST LATERAL DEFLECTION
NEUTRAL AXIS PARALLEL TO LONGER LEG

Maximum fiber stress, 18,000 pounds per square inch

Span in Feet	8 X 6									
	1	$\frac{15}{16}$	$\frac{7}{8}$	$\frac{13}{16}$	$\frac{3}{4}$	$\frac{11}{16}$	$\frac{5}{8}$	$\frac{9}{16}$	$\frac{1}{2}$	$\frac{7}{16}$
2	53.5	50.6	47.6	44.6	41.6	38.4	35.3	32.0	28.7	25.4
3	35.7	33.7	31.8	29.7	27.7	25.6	23.5	21.3	19.2	16.9
4	26.8	25.3	23.8	22.3	20.8	19.2	17.6	16.0	14.4	12.7
5	21.4	20.2	19.1	17.8	16.6	15.4	14.1	12.8	11.5	10.2
6	17.8	16.9	15.9	14.9	13.9	12.8	11.8	10.7	9.6	8.5
7	15.3	14.5	13.6	12.7	11.9	11.0	10.1	9.1	8.2	7.3
8	13.4	12.7	11.9	11.2	10.4	9.6	8.8	8.0	7.2	6.3
9	11.9	11.2	10.6	9.9	9.2	8.5	7.8	7.1	6.4	5.6
10	10.7	10.1	9.5	8.9	8.3	7.7	7.1	6.4	5.7	5.1
11	9.7	9.2	8.7	8.1	7.6	7.0	6.4	5.8	5.2	4.6
12	8.9	8.4	7.9	7.4	6.9	6.4	5.9	5.3	4.8	4.2
13	8.2	7.8	7.3	6.9	6.4	5.9	5.4	4.9	4.4	3.9
14	7.6	7.2	6.8	6.4	5.9	5.5	5.0	4.6	4.1	3.6
15	7.1	6.7	6.4	5.9	5.5	5.1	4.7	4.3	3.8	3.4
16	6.7	6.3	6.0	5.6	5.2	4.8	4.4	4.0	3.6	3.2
17	6.3	6.0	5.6	5.2	4.9	4.5	4.1	3.8	3.4	3.0
18	5.9	5.6	5.3	5.0	4.6	4.3	3.9	3.6	3.2	2.8
19	5.6	5.3	5.0	4.7	4.4	4.0	3.7	3.4	3.0	2.7
20	5.4	5.1	4.8	4.5	4.2	3.8	3.5	3.2	2.9	2.5
21	5.1	4.8	4.5	4.2	4.0	3.7	3.4	3.0	2.7	2.4
22	4.9	4.6	4.3	4.1	3.8	3.5	3.2	2.9	2.6	2.3

Loads below the dotted line produce deflections exceeding 1/360 of the span

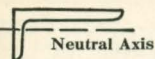

Neutral Axis

ANGLES, UNEQUAL LEGS

ALLOWABLE UNIFORM LOADS IN THOUSANDS OF POUNDS
FOR ANGLES BRACED AGAINST LATERAL DEFLECTION
NEUTRAL AXIS PARALLEL TO LONGER LEG

Maximum fiber stress, 18,000 pounds per square inch

Span in Feet	$8 \times 3\frac{1}{2}$										
	1	$1\frac{5}{16}$	$\frac{7}{8}$	$1\frac{3}{16}$	$\frac{3}{4}$	$1\frac{1}{16}$	$\frac{5}{8}$	$\frac{9}{16}$	$\frac{1}{2}$	$\frac{7}{16}$	
2	18.1	17.1	16.1	15.1	14.1	13.0	12.0	10.9	9.8	8.7	
3	12.1	11.4	10.7	10.1	9.4	8.7	8.0	7.3	6.6	5.8	
4	9.1	8.6	8.1	7.5	7.0	6.5	6.0	5.5	4.9	4.4	
5	7.2	6.8	6.4	6.0	5.6	5.2	4.8	4.4	3.9	3.5	
6	6.0	5.7	5.4	5.0	4.7	4.3	4.0	3.6	3.3	2.9	
7	5.2	4.9	4.6	4.3	4.0	3.7	3.4	3.1	2.8	2.5	
8	4.5	4.3	4.0	3.8	3.5	3.3	3.0	2.7	2.5	2.2	
9	4.0	3.8	3.6	3.4	3.1	2.9	2.7	2.4	2.2	1.9	
10	3.6	3.4	3.2	3.0	2.8	2.6	2.4	2.2	2.0	1.7	

Span in Feet	$7 \times 3\frac{1}{2}$										
	1	$1\frac{5}{16}$	$\frac{7}{8}$	$1\frac{3}{16}$	$\frac{3}{4}$	$1\frac{1}{16}$	$\frac{5}{8}$	$\frac{9}{16}$	$\frac{1}{2}$	$\frac{7}{16}$	$\frac{3}{8}$
2	17.8	16.8	15.8	14.9	13.9	12.9	11.8	10.8	9.7	8.6	7.5
3	11.9	11.2	10.6	9.9	9.2	8.6	7.9	7.2	6.5	5.7	5.0
4	8.9	8.4	7.9	7.4	6.9	6.4	5.9	5.4	4.9	4.3	3.8
5	7.1	6.7	6.3	5.9	5.5	5.1	4.7	4.3	3.9	3.4	3.0
6	5.9	5.6	5.3	5.0	4.6	4.3	3.9	3.6	3.2	2.9	2.5
7	5.1	4.8	4.5	4.2	4.0	3.7	3.4	3.1	2.8	2.5	2.1
8	4.4	4.2	4.0	3.7	3.5	3.2	3.0	2.7	2.4	2.2	1.9
9	4.0	3.7	3.5	3.3	3.1	2.9	2.6	2.4	2.2	1.9	1.7
10	3.6	3.4	3.2	3.0	2.8	2.6	2.4	2.2	1.9	1.7	1.5
11	3.2	3.1	2.9	2.7	2.5	2.3	2.2	2.0	1.8	1.6	1.4
12	3.0	2.8	2.6	2.5	2.3	2.1	2.0	1.8	1.6	1.4	1.3
13	2.7	2.6	2.4	2.3	2.1	2.0	1.8	1.7	1.5	1.3	1.2

Loads below the dotted line produce deflections exceeding $1/360$ of the span

ANGLES, UNEQUAL LEGS

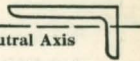

 Neutral Axis

ALLOWABLE UNIFORM LOADS IN THOUSANDS OF POUNDS
FOR ANGLES BRACED AGAINST LATERAL DEFLECTION
NEUTRAL AXIS PARALLEL TO LONGER LEG

Maximum fiber stress, 18,000 pounds per square inch

Span in Feet	6 × 4											
	1	$\frac{15}{16}$	$\frac{7}{8}$	$\frac{13}{16}$	$\frac{3}{4}$	$\frac{11}{16}$	$\frac{5}{8}$	$\frac{9}{16}$	$\frac{1}{2}$	$\frac{7}{16}$	$\frac{3}{8}$	
2	22.8	21.6	20.3	19.1	17.8	16.5	15.2	13.9	12.5	11.1	9.6	
3	15.2	14.4	13.6	12.7	11.9	11.0	10.1	9.2	8.3	7.4	6.4	
4	11.4	10.8	10.2	9.5	8.9	8.3	7.6	6.9	6.2	5.5	4.8	
5	9.1	8.6	8.1	7.6	7.1	6.6	6.1	5.5	5.0	4.4	3.8	
6	7.6	7.2	6.8	6.4	5.9	5.5	5.1	4.6	4.2	3.7	3.2	
7	6.5	6.2	5.8	5.5	5.1	4.7	4.3	4.0	3.6	3.2	2.8	
8	5.7	5.4	5.1	4.8	4.5	4.1	3.8	3.5	3.1	2.8	2.4	
9	5.1	4.8	4.5	4.2	4.0	3.7	3.4	3.1	2.8	2.5	2.1	
10	4.6	4.3	4.1	3.8	3.6	3.3	3.0	2.8	2.5	2.2	1.9	
11	4.1	3.9	3.7	3.5	3.2	3.0	2.8	2.5	2.3	2.0	1.7	
12	3.8	3.6	3.4	3.2	3.0	2.8	2.5	2.3	2.1	1.8	1.6	
13	3.5	3.3	3.1	2.9	2.7	2.5	2.3	2.1	1.9	1.7	1.5	
14	3.3	3.1	2.9	2.7	2.5	2.4	2.2	2.0	1.8	1.6	1.4	
15	3.0	2.9	2.7	2.5	2.4	2.2	2.0	1.8	1.7	1.5	1.3	
	6 × 3½											
Span in Feet	1	$\frac{15}{16}$	$\frac{7}{8}$	$\frac{13}{16}$	$\frac{3}{4}$	$\frac{11}{16}$	$\frac{5}{8}$	$\frac{9}{16}$	$\frac{1}{2}$	$\frac{7}{16}$	$\frac{3}{8}$	$\frac{1}{4}$
2	17.4	16.5	15.5	14.6	13.6	12.6	11.6	10.6	9.6	8.5	7.4	6.3
3	11.6	11.0	10.4	9.7	9.1	8.4	7.8	7.1	6.4	5.7	4.9	4.2
4	8.7	8.2	7.8	7.3	6.8	6.3	5.8	5.3	4.8	4.2	3.7	3.1
5	7.0	6.6	6.2	5.8	5.4	5.1	4.7	4.2	3.8	3.4	3.0	2.5
6	5.8	5.5	5.2	4.9	4.5	4.2	3.9	3.5	3.2	2.8	2.5	2.1
7	5.0	4.7	4.4	4.2	3.9	3.6	3.3	3.0	2.7	2.4	2.1	1.8
8	4.3	4.1	3.9	3.6	3.4	3.2	2.9	2.7	2.4	2.1	1.8	1.6
9	3.9	3.7	3.5	3.2	3.0	2.8	2.6	2.4	2.1	1.9	1.6	1.4
10	3.5	3.3	3.1	2.9	2.7	2.5	2.3	2.1	1.9	1.7	1.5	1.3
11	3.2	3.0	2.8	2.7	2.5	2.3	2.1	1.9	1.7	1.5	1.3	1.1
12	2.9	2.7	2.6	2.4	2.3	2.1	1.9	1.8	1.6	1.4	1.2	1.0
13	2.7	2.5	2.4	2.2	2.1	1.9	1.8	1.6	1.5	1.3	1.1	.96

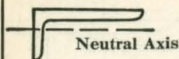
Loads below the dotted line produce deflections exceeding 1/360 of the span



Neutral Axis

ANGLES, UNEQUAL LEGS

ALLOWABLE UNIFORM LOADS IN THOUSANDS OF POUNDS
FOR ANGLES BRACED AGAINST LATERAL DEFLECTION
NEUTRAL AXIS PARALLEL TO LONGER LEG

Maximum fiber stress, 18,000 pounds per square inch

Span in Feet	5 × 4									
	$\frac{7}{8}$	$\frac{13}{16}$	$\frac{3}{4}$	$\frac{11}{16}$	$\frac{5}{8}$	$\frac{9}{16}$	$\frac{1}{2}$	$\frac{7}{16}$	$\frac{3}{8}$	$\frac{5}{16}$
2	19.8	18.6	17.4	16.2	14.9	13.6	12.2	10.8	9.4	8.0
3	13.2	12.4	11.6	10.8	9.9	9.0	8.1	7.2	6.3	5.3
4	9.9	9.3	8.7	8.1	7.4	6.8	6.1	5.4	4.7	4.0
5	7.9	7.5	7.0	6.5	6.0	5.4	4.9	4.3	3.8	3.2
6	6.6	6.2	5.8	5.4	5.0	4.5	4.1	3.6	3.1	2.7
7	5.7	5.3	5.0	4.6	4.3	3.9	3.5	3.1	2.7	2.3
8	5.0	4.7	4.4	4.0	3.7	3.4	3.1	2.7	2.4	2.0
9	4.4	4.1	3.9	3.6	3.3	3.0	2.7	2.4	2.1	1.8
10	4.0	3.7	3.5	3.2	3.0	2.7	2.4	2.2	1.9	1.6
11	3.6	3.4	3.2	2.9	2.7	2.5	2.2	2.0	1.7	1.5
12	3.3	3.1	2.9	2.7	2.5	2.3	2.0	1.8	1.6	1.3
13	3.1	2.9	2.7	2.5	2.3	2.1	1.9	1.7	1.5	1.2
14	2.8	2.7	2.5	2.3	2.1	1.9	1.7	1.6	1.3	1.1
Span in Feet	5 × 3½									
	$\frac{7}{8}$	$\frac{13}{16}$	$\frac{3}{4}$	$\frac{11}{16}$	$\frac{5}{8}$	$\frac{9}{16}$	$\frac{1}{2}$	$\frac{7}{16}$	$\frac{3}{8}$	$\frac{5}{16}$
2	15.1	14.2	13.3	12.4	11.4	10.4	9.4	8.3	7.2	6.1
3	10.1	9.5	8.9	8.2	7.6	6.9	6.2	5.5	4.8	4.1
4	7.6	7.1	6.7	6.2	5.7	5.2	4.7	4.2	3.6	3.1
5	6.1	5.7	5.3	4.9	4.6	4.2	3.7	3.3	2.9	2.5
6	5.0	4.7	4.4	4.1	3.8	3.5	3.1	2.8	2.4	2.0
7	4.3	4.1	3.8	3.5	3.3	3.0	2.7	2.4	2.1	1.8
8	3.8	3.6	3.3	3.1	2.8	2.6	2.3	2.1	1.8	1.5
9	3.4	3.2	3.0	2.7	2.5	2.3	2.1	1.8	1.6	1.4
10	3.0	2.8	2.7	2.5	2.3	2.1	1.9	1.7	1.4	1.2
11	2.8	2.6	2.4	2.2	2.1	1.9	1.7	1.5	1.3	1.1
12	2.5	2.4	2.2	2.1	1.9	1.7	1.6	1.4	1.2	1.0
13	2.3	2.2	2.0	1.9	1.8	1.6	1.4	1.3	1.1	.94

Loads below the dotted line produce deflections exceeding 1/360 of the span

ANGLES, UNEQUAL LEGS

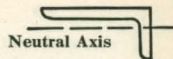

ALLOWABLE UNIFORM LOADS IN THOUSANDS OF POUNDS
FOR ANGLES BRACED AGAINST LATERAL DEFLECTION
NEUTRAL AXIS PARALLEL TO LONGER LEG

Maximum fiber stress, 18,000 pounds per square inch

Span in Feet	5 × 3								
	13/16	3/4	11/16	5/8	9/16	1/2	7/16	3/8	5/16
2	10.4	9.7	9.0	8.3	7.6	6.9	6.1	5.3	4.5
3	7.0	6.5	6.0	5.6	5.1	4.6	4.1	3.6	3.0
4	5.2	4.9	4.5	4.2	3.8	3.4	3.1	2.7	2.3
5	4.2	3.9	3.6	3.3	3.1	2.8	2.5	2.1	1.8
6	3.5	3.2	3.0	2.8	2.5	2.3	2.0	1.8	1.5
7	3.0	2.8	2.6	2.4	2.2	2.0	1.7	1.5	1.3
8	2.6	2.4	2.3	2.1	1.9	1.7	1.5	1.3	1.1
9	2.3	2.2	2.0	1.9	1.7	1.5	1.4	1.2	1.0
10	2.1	1.9	1.8	1.7	1.5	1.4	1.2	1.1	.90
11	1.9	1.8	1.6	1.5	1.4	1.3	1.1	.97	.82
Span in Feet	4 × 3 1/2								
	13/16	3/4	11/16	5/8	9/16	1/2	7/16	3/8	5/16
2	13.8	12.9	12.0	11.0	10.1	9.1	8.1	7.0	6.0
3	9.2	8.6	8.0	7.4	6.7	6.1	5.4	4.7	4.0
4	6.9	6.4	6.0	5.5	5.0	4.6	4.0	3.5	3.0
5	5.5	5.2	4.8	4.4	4.0	3.6	3.2	2.8	2.4
6	4.6	4.3	4.0	3.7	3.4	3.0	2.7	2.3	2.0
7	3.9	3.7	3.4	3.2	2.9	2.6	2.3	2.0	1.7
8	3.4	3.2	3.0	2.8	2.5	2.3	2.0	1.8	1.5
9	3.1	2.9	2.7	2.5	2.2	2.0	1.8	1.6	1.3
10	2.8	2.6	2.4	2.2	2.0	1.8	1.6	1.4	1.2
11	2.5	2.3	2.2	2.0	1.8	1.7	1.5	1.3	1.1
12	2.3	2.1	2.0	1.8	1.7	1.5	1.3	1.2	.99
13	2.1	2.0	1.8	1.7	1.6	1.4	1.2	1.1	.92

Loads below the dotted line produce deflections exceeding 1/360 of the span

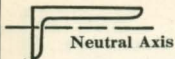

Neutral Axis

ANGLES, UNEQUAL LEGS

ALLOWABLE UNIFORM LOADS IN THOUSANDS OF POUNDS
FOR ANGLES BRACED AGAINST LATERAL DEFLECTION
NEUTRAL AXIS PARALLEL TO LONGER LEG

Maximum fiber stress, 18,000 pounds per square inch

Span in Feet	4 × 3									
	$\frac{13}{16}$	$\frac{3}{4}$	$1\frac{1}{16}$	$\frac{5}{8}$	$\frac{9}{16}$	$\frac{1}{2}$	$\frac{7}{16}$	$\frac{3}{8}$	$\frac{5}{16}$	$\frac{1}{4}$
2	10.1	9.4	8.8	8.1	7.4	6.7	6.0	5.2	4.4	3.6
3	6.7	6.3	5.9	5.4	4.9	4.5	4.0	3.5	2.9	2.4
4	5.0	4.7	4.4	4.1	3.7	3.3	3.0	2.6	2.2	1.8
5	4.0	3.8	3.5	3.2	3.0	2.7	2.4	2.1	1.8	1.4
6	3.4	3.1	2.9	2.7	2.5	2.2	2.0	1.7	1.5	1.2
7	2.9	2.7	2.5	2.3	2.1	1.9	1.7	1.5	1.3	1.0
8	2.5	2.4	2.2	2.0	1.9	1.7	1.5	1.3	1.1	.90
9	2.2	2.1	2.0	1.8	1.6	1.5	1.3	1.2	.98	.80
10	2.0	1.9	1.8	1.6	1.5	1.3	1.2	1.0	.88	.72
11	1.8	1.7	1.6	1.5	1.3	1.2	1.1	.94	.80	.65

Span in Feet	$3\frac{1}{2} \times 3$									
	$\frac{13}{16}$	$\frac{3}{4}$	$1\frac{1}{16}$	$\frac{5}{8}$	$\frac{9}{16}$	$\frac{1}{2}$	$\frac{7}{16}$	$\frac{3}{8}$	$\frac{5}{16}$	$\frac{1}{4}$
2	9.9	9.3	8.6	8.0	7.3	6.6	5.9	5.1	4.3	3.5
3	6.6	6.2	5.7	5.3	4.8	4.4	3.9	3.4	2.9	2.4
4	4.9	4.6	4.3	4.0	3.6	3.3	2.9	2.6	2.2	1.8
5	4.0	3.7	3.4	3.2	2.9	2.6	2.3	2.0	1.7	1.4
6	3.3	3.1	2.9	2.7	2.4	2.2	2.0	1.7	1.4	1.2
7	2.8	2.6	2.5	2.3	2.1	1.9	1.7	1.5	1.2	1.0
8	2.5	2.3	2.2	2.0	1.8	1.6	1.5	1.3	1.1	.88
9	2.2	2.1	1.9	1.8	1.6	1.5	1.3	1.1	.96	.78
10	2.0	1.9	1.7	1.6	1.5	1.3	1.2	1.0	.87	.71
11	1.8	1.7	1.6	1.4	1.3	1.2	1.1	.93	.79	.64

Loads below the dotted line produce deflections exceeding $1/360$ of the span

ANGLES, UNEQUAL LEGS

 Neutral Axis

ALLOWABLE UNIFORM LOADS IN THOUSANDS OF POUNDS
FOR ANGLES BRACED AGAINST LATERAL DEFLECTION
NEUTRAL AXIS PARALLEL TO LONGER LEG

Maximum fiber stress, 18,000 pounds per square inch

Span in Feet	$3\frac{1}{2} \times 2\frac{1}{2}$							
	$\frac{1}{16}$	$\frac{5}{8}$	$\frac{3}{16}$	$\frac{1}{2}$	$\frac{7}{16}$	$\frac{3}{8}$	$\frac{5}{16}$	$\frac{1}{4}$
2	6.0	5.5	5.0	4.6	4.1	3.6	3.0	2.5
3	4.0	3.7	3.4	3.0	2.7	2.4	2.0	1.6
4	3.0	2.8	2.5	2.3	2.0	1.8	1.5	1.2
5	2.4	2.2	2.0	1.8	1.6	1.4	1.2	.99
6	2.0	1.8	1.7	1.5	1.4	1.2	1.0	.82
7	1.7	1.6	1.4	1.3	1.2	1.0	.86	.71
8	1.5	1.4	1.3	1.1	1.0	.89	.76	.62
9	1.3	1.2	1.1	1.0	.90	.79	.67	.55

Span in Feet	$3 \times 2\frac{1}{2}$					
	$\frac{5}{16}$	$\frac{1}{2}$	$\frac{7}{16}$	$\frac{3}{8}$	$\frac{5}{16}$	$\frac{1}{4}$
2	4.9	4.5	4.0	3.5	3.0	2.4
3	3.3	3.0	2.7	2.3	2.0	1.6
4	2.5	2.2	2.0	1.7	1.5	1.2
5	2.0	1.8	1.6	1.4	1.2	.97
6	1.6	1.5	1.3	1.2	.99	.81
7	1.4	1.3	1.1	1.0	.85	.69
8	1.2	1.1	1.0	.87	.74	.61
9	1.1	.99	.89	.77	.66	.54

Loads below the dotted line produce deflections exceeding $1/360$ of the span

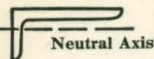

Neutral Axis

ANGLES, UNEQUAL LEGS

ALLOWABLE UNIFORM LOADS IN THOUSANDS OF POUNDS
FOR ANGLES BRACED AGAINST LATERAL DEFLECTION
NEUTRAL AXIS PARALLEL TO LONGER LEG

Maximum fiber stress, 18,000 pounds per square inch

Span in Feet	3 × 2					
	½	⅜	⅜	⅝	¾	¾
2	2.8	2.5	2.2	1.9	1.6	1.6
3	1.9	1.7	1.5	1.3	1.0	1.0
4	1.4	1.3	1.1	.95	.78	.78
5	1.1	1.0	.89	.76	.62	.62
6	.95	.85	.74	.63	.52	.52
7	.81	.73	.64	.54	.45	.45
8	.71	.64	.56	.48	.39	.39
9	.63	.56	.50	.42	.35	.35

Span in Feet	2½ × 2						
	½	⅜	⅜	⅝	¾	⅝	⅝
2	2.8	2.5	2.2	1.9	1.5	1.2	.81
3	1.8	1.7	1.5	1.2	1.0	.79	.54
4	1.4	1.2	1.1	.93	.76	.59	.40
5	1.1	.99	.87	.74	.61	.47	.32
6	.92	.83	.73	.62	.51	.39	.27
7	.79	.71	.62	.53	.44	.34	.23
8	.69	.62	.54	.46	.38	.30	.20

Loads below the dotted line produce deflections exceeding 1/360 of the span

RADII OF GYRATION FOR TWO ANGLES PLACED BACK TO BACK

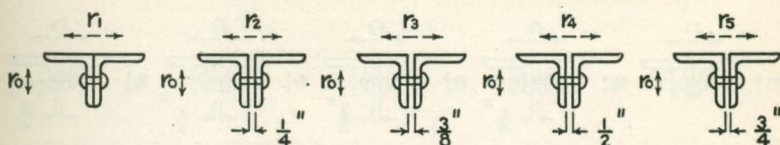

ANGLES WITH EQUAL LEGS

Radii of Gyration given correspond to directions indicated by arrow heads

Size, Inches	Thickness, Inches	Area of Double Angles, Square Inches	Weight Per Foot of Single Angle, lbs.	RADII OF GYRATION					
				r_0	r_1	r_2	r_3	r_4	r_5
8 × 8	$1\frac{1}{8}$	33.46	56.9	2.42	3.42	3.51	3.55	3.60	3.69
8 × 8	$\frac{1}{2}$	15.50	26.4	2.50	3.32	3.41	3.45	3.49	3.58
6 × 6	1	22.00	37.4	1.80	2.59	2.68	2.72	2.77	2.87
6 × 6	$\frac{3}{8}$	8.76	14.9	1.88	2.49	2.58	2.62	2.66	2.75
5 × 5	1	18.00	30.6	1.48	2.19	2.28	2.33	2.38	2.48
5 × 5	$\frac{3}{8}$	7.22	12.3	1.56	2.09	2.17	2.21	2.26	2.35
4 × 4	$\frac{13}{16}$	11.68	19.9	1.18	1.75	1.85	1.89	1.94	2.04
4 × 4	$\frac{1}{4}$	3.88	6.6	1.25	1.66	1.75	1.79	1.84	1.93
$3\frac{1}{2} \times 3\frac{1}{2}$	$\frac{13}{16}$	10.06	17.1	1.02	1.55	1.65	1.70	1.75	1.85
$3\frac{1}{2} \times 3\frac{1}{2}$	$\frac{1}{4}$	3.42	5.8	1.09	1.46	1.55	1.59	1.64	1.73
3 × 3	$\frac{5}{8}$	6.76	11.5	0.88	1.32	1.41	1.46	1.51	1.61
3 × 3	$\frac{1}{4}$	2.88	4.9	0.93	1.25	1.34	1.38	1.43	1.53
$2\frac{1}{2} \times 2\frac{1}{2}$	$\frac{1}{2}$	4.50	7.7	0.74	1.09	1.19	1.24	1.29	1.39
$2\frac{1}{2} \times 2\frac{1}{2}$	$\frac{1}{4}$	2.42	4.1	0.77	1.05	1.14	1.19	1.24	1.34
2 × 2	$\frac{7}{16}$	3.12	5.3	0.59	0.88	0.98	1.03	1.08	1.19
2 × 2	$\frac{1}{4}$	1.88	3.19	0.61	0.85	0.94	0.99	1.04	1.14

RADII OF GYRATION FOR TWO ANGLES PLACED BACK TO BACK

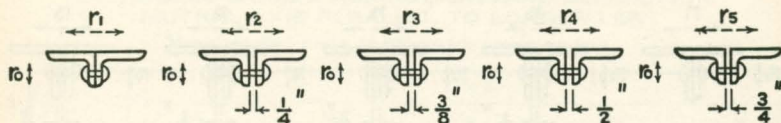

ANGLES WITH UNEQUAL LEGS

Radii of Gyration given correspond to directions indicated by arrow heads

Size, Inches	Thickness, Inches	Area of Single Angle, Square Inches	Weight Per Foot of Single Angle, lbs.	RADII OF GYRATION					
				r ₀	r ₁	r ₂	r ₃	r ₄	r ₅
8 × 6	1	26.00	44.2	1.73	3.64	3.73	3.78	3.83	3.92
8 × 6	7/16	11.86	20.2	1.80	3.55	3.64	3.68	3.73	3.82
8 × 3 1/2	1	21.00	35.7	0.86	4.04	4.14	4.19	4.24	4.34
8 × 3 1/2	7/16	9.68	16.5	0.92	3.93	4.02	4.07	4.12	4.22
6 × 4	1	18.00	30.6	1.09	2.85	2.95	2.99	3.04	3.14
6 × 4	3/8	7.22	12.3	1.17	2.74	2.83	2.87	2.92	3.02
6 × 3 1/2	1	17.00	28.9	0.92	2.93	3.02	3.07	3.12	3.23
6 × 3 1/2	5/16	5.74	9.8	1.00	2.80	2.89	2.94	2.99	3.08
5 × 4	7/8	14.22	24.2	1.14	2.29	2.38	2.43	2.48	2.58
5 × 4	3/8	6.46	11.0	1.20	2.20	2.29	2.34	2.38	2.48
5 × 3 1/2	7/8	13.34	22.7	0.96	2.36	2.45	2.50	2.55	2.65
5 × 3 1/2	5/16	5.12	8.7	1.03	2.26	2.35	2.39	2.44	2.54
5 × 3	13/16	11.68	19.9	0.80	2.42	2.52	2.57	2.62	2.72
5 × 3	5/16	4.80	8.2	0.85	2.33	2.42	2.47	2.52	2.61
4 × 3 1/2	13/16	10.86	18.5	1.01	1.81	1.91	1.96	2.01	2.11
4 × 3 1/2	5/16	4.50	7.7	1.07	1.73	1.81	1.86	1.91	2.00
4 × 3	13/16	10.06	17.1	0.83	1.88	1.97	2.02	2.08	2.18
4 × 3	1/4	3.42	5.8	0.90	1.78	1.87	1.92	1.96	2.06
3 1/2 × 3	13/16	9.30	15.8	0.85	1.61	1.71	1.76	1.81	1.91
3 1/2 × 3	1/4	3.18	5.4	0.91	1.52	1.60	1.65	1.70	1.79
3 1/2 × 2 1/2	11/16	7.36	12.5	0.69	1.66	1.75	1.80	1.86	1.96
3 1/2 × 2 1/2	1/4	2.88	4.9	0.74	1.58	1.67	1.71	1.76	1.86
3 × 2 1/2	9/16	5.56	9.5	0.72	1.37	1.46	1.51	1.56	1.66
3 × 2 1/2	1/4	2.62	4.5	0.75	1.31	1.40	1.45	1.50	1.59
3 × 2	1/2	4.50	7.7	0.55	1.42	1.52	1.57	1.62	1.73
3 × 2	1/4	2.42	4.1	0.57	1.38	1.47	1.52	1.57	1.67
2 1/2 × 2	1/2	4.00	6.8	0.56	1.15	1.25	1.30	1.35	1.46
2 1/2 × 2	1/4	2.12	3.62	0.59	1.11	1.20	1.25	1.30	1.40

RADIi OF GYRATION FOR TWO ANGLES PLACED BACK TO BACK

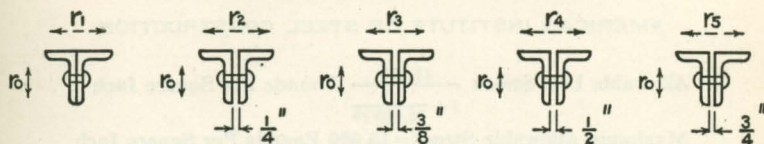

ANGLES WITH UNEQUAL LEGS

Radii of Gyration given correspond to directions indicated by arrow heads

Size, Inches	Thickness, Inches	Area of Single Angle, Square Inches	Weight Per Foot of Single Angle, lbs.	RADIi OF GYRATION					
				r ₀	r ₁	r ₂	r ₃	r ₄	r ₅
8 × 6	1	26.00	44.2	2.49	2.39	2.48	2.52	2.57	2.66
8 × 6	7/16	11.86	20.2	2.57	2.31	2.39	2.43	2.48	2.56
8 × 3 1/2	1	21.00	35.7	2.51	1.26	1.35	1.40	1.45	1.55
8 × 3 1/2	7/16	9.68	16.5	2.59	1.16	1.24	1.28	1.32	1.42
6 × 4	1	18.00	30.6	1.85	1.60	1.69	1.74	1.79	1.89
6 × 4	3/8	7.22	12.3	1.93	1.50	1.58	1.61	1.67	1.76
6 × 3 1/2	1	17.00	28.9	1.85	1.37	1.47	1.51	1.56	1.67
6 × 3 1/2	5/16	5.74	9.8	1.95	1.26	1.33	1.38	1.42	1.51
5 × 4	7/8	14.22	24.2	1.52	1.66	1.75	1.80	1.85	1.95
5 × 4	3/8	6.46	11.0	1.59	1.58	1.66	1.70	1.75	1.85
5 × 3 1/2	7/8	13.34	22.7	1.53	1.42	1.51	1.56	1.61	1.71
5 × 3 1/2	5/16	5.12	8.7	1.61	1.33	1.41	1.45	1.50	1.59
5 × 3	13/16	11.68	19.9	1.55	1.17	1.27	1.32	1.37	1.47
5 × 3	5/16	4.80	8.2	1.61	1.09	1.17	1.22	1.26	1.36
4 × 3 1/2	13/16	10.86	18.5	1.20	1.50	1.59	1.64	1.69	1.79
4 × 3 1/2	5/16	4.50	7.7	1.26	1.42	1.51	1.55	1.60	1.69
4 × 3	13/16	10.06	17.1	1.21	1.25	1.35	1.40	1.45	1.55
4 × 3	1/4	3.42	5.8	1.28	1.16	1.24	1.29	1.33	1.43
3 1/2 × 3	13/16	9.30	15.8	1.04	1.30	1.40	1.45	1.50	1.60
3 1/2 × 3	1/4	3.18	5.4	1.11	1.20	1.29	1.33	1.38	1.48
3 1/2 × 2 1/2	1 1/16	7.36	12.5	1.06	1.03	1.13	1.18	1.23	1.33
3 1/2 × 2 1/2	1/4	2.88	4.9	1.12	0.95	1.04	1.09	1.13	1.23
3 × 2 1/2	9/16	5.56	9.5	0.91	1.05	1.15	1.20	1.25	1.35
3 × 2 1/2	1/4	2.62	4.5	0.95	1.00	1.09	1.13	1.18	1.28
3 × 2	1/2	4.50	7.7	0.92	0.80	0.89	0.94	1.00	1.10
3 × 2	1/4	2.42	4.1	0.95	0.74	0.84	0.88	0.93	1.03
2 1/2 × 2	1/2	4.00	6.8	0.75	0.84	0.94	0.99	1.04	1.15
2 1/2 × 2	1/4	2.12	3.62	0.78	0.80	0.89	0.93	0.98	1.08

ALLOWABLE UNIT STRESSES FOR COLUMNS

AMERICAN INSTITUTE OF STEEL CONSTRUCTION

Allowable Unit Stress $\frac{18,000}{1 + \frac{l^2}{18,000 r^2}}$ Pounds Per Square Inch

Maximum Allowable Stress = 15,000 Pounds Per Square Inch

Maximum $\frac{l}{r} = \begin{cases} 120 & \text{for Main Members} \\ 200 & \text{for Secondary Members} \end{cases}$

Ratio $\frac{l}{r}$	Allowable Stress. Pounds per Square Inch	Ratio $\frac{l}{r}$	Allowable Stress. Pounds per Square Inch	Ratio $\frac{l}{r}$	Allowable Stress. Pounds per Square Inch	Ratio $\frac{l}{r}$	Allowable Stress. Pounds per Square Inch
60	15,000	85	12,844	110	10,764	135	8,944
61	14,916	86	12,758	111	10,686	136	8,878
62	14,832	87	12,672	112	10,608	137	8,812
63	14,748	88	12,585	113	10,530	138	8,746
64	14,663	89	12,500	114	10,453	139	8,681
65	14,578	90	12,414	115	10,376	140	8,617
66	14,493	91	12,328	116	10,300	141	8,553
67	14,407	92	12,243	117	10,224	142	8,490
68	14,321	93	12,158	118	10,149	143	8,427
69	14,235	94	12,073	119	10,074	144	8,364
70	14,148	95	11,989	120	10,000	145	8,302
71	14,062	96	11,905	121	9,926	146	8,241
72	13,975	97	11,821	122	9,853	147	8,180
73	13,888	98	11,737	123	9,780	148	8,119
74	13,801	99	11,654	124	9,708	149	8,060
75	13,714	100	11,571	125	9,636	150	8,000
76	13,627	101	11,489	126	9,564	155	7,710
77	13,540	102	11,407	127	9,493	160	7,431
78	13,453	103	11,325	128	9,423	165	7,164
79	13,366	104	11,244	129	9,353	170	6,908
80	13,279	105	11,163	130	9,284	175	6,663
81	13,192	106	11,082	131	9,215	180	6,429
82	13,105	107	11,002	132	9,146	185	6,204
83	13,018	108	10,922	133	9,078	190	5,989
84	12,931	109	10,843	134	9,011	200	5,586

l = Unsupported Length of Column, Inches.

r = Corresponding Radius of Gyration, Inches.

Safe Concentric Load on Column = Cross Sectional Area times Allowable Unit Stress.

**MISCELLANEOUS
ENGINEERING DATA**

BEAMS UNDER VARIOUS LOADING CONDITIONS

BENDING MOMENTS AND DEFLECTIONS

P or W = Applied load in pounds
l = Length in inches

I = Moment of inertia, inches⁴
E = Modulus of elasticity, lbs. per sq. in.

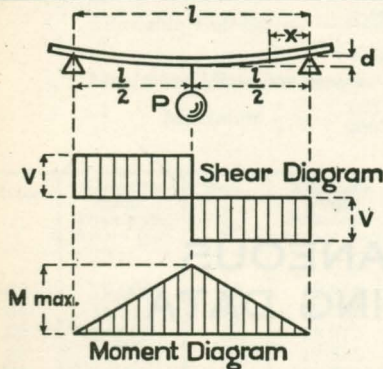

SIMPLE BEAM SINGLE LOAD AT CENTER

Safe load = $\frac{1}{2}$ tabular load

Shear at any point = $\frac{P}{2}$

Maximum shear, $V = \frac{P}{2}$

Bending moment at any point = $\frac{Px}{2}$

for $x = 0$ to $x = \frac{1}{2}$ inclusive

Bending moment at center,

$M \text{ max.} = \frac{Pl}{4}$

Maximum deflection, at center,

$d = \frac{Pl^3}{48EI}$

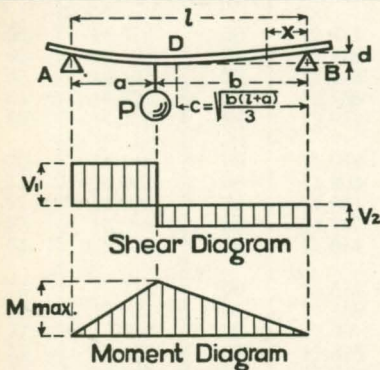

SIMPLE BEAM SINGLE LOAD AT ANY POINT

Safe load = tabular load $\times \frac{P}{8ab}$

Shear at any point.

Between A and P, $V_1 = \frac{Pb}{l}$

Between B and P, $V_2 = \frac{Pa}{l}$

Bending moment at any point:

Between A and P, $M = \frac{Pb}{l}(l-x)$

Between B and P, $M = \frac{Pax}{l}$

Bending moment at P, $M \text{ max.} = \frac{Pab}{l}$

Maximum deflection, at D,

$d = \frac{Pab(l+a)}{9EI} \cdot \frac{c}{l}$ NOTE $b > a$

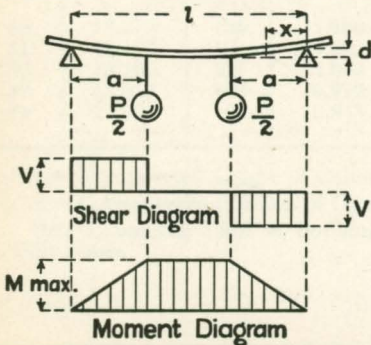

SIMPLE BEAM TWO SYMMETRICAL LOADS

Safe load = tabular load $\times \frac{l}{4a}$

Shear at any point.

Between load and support, $V = \frac{P}{2}$

Between loads, shear = 0

Bending moment at any point:

Between load and support, $M = Vx$

for $x = 0$ to $x = a$ inclusive

Between loads, $M \text{ max.} = \frac{Pa}{2}$

Maximum deflection, at center,

$d = \frac{Pa}{48EI} (3l^2 - 4a^2)$

BEAMS UNDER VARIOUS LOADING CONDITIONS

BENDING MOMENTS AND DEFLECTIONS

P or W = Applied load in pounds
l = Length in inches

I = Moment of inertia, inches⁴
E = Modulus of elasticity, lbs. per sq. in.

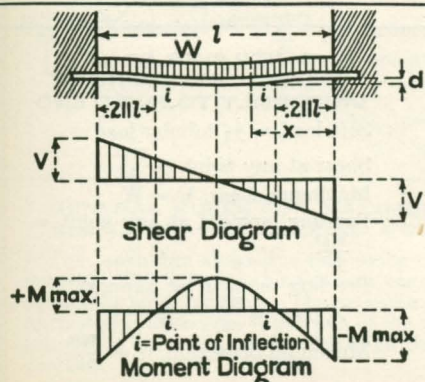
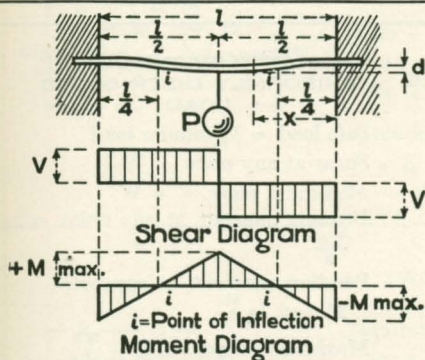
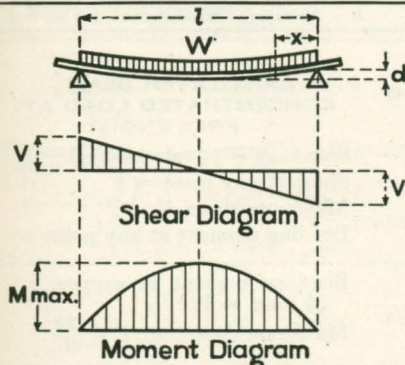

BEAMS UNDER VARIOUS LOADING CONDITIONS

BENDING MOMENTS AND DEFLECTIONS

P or W = Applied load in pounds
l = Length in inches

I = Moment of inertia, inches⁴
E = Modulus of elasticity, lbs. per sq. inch

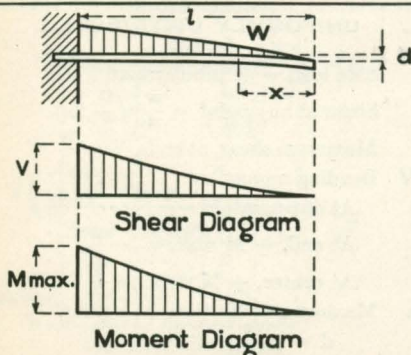
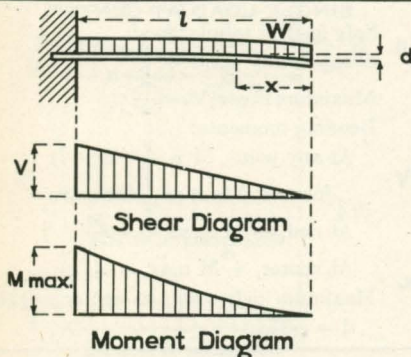
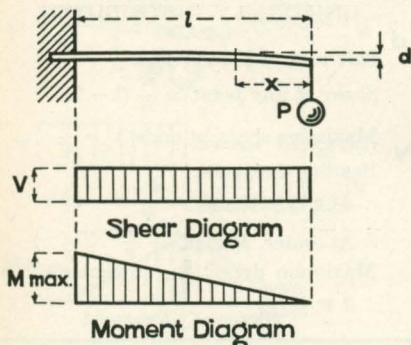

BEAMS UNDER VARIOUS LOADING CONDITIONS

MOVING LOADS

NOTE: In the case of Moving Loads, proper allowance should be made for impact.

P, P_1 or P_2 = Moving load in pounds l, a or x = Distances in inches
 Bending moments are in inch pounds

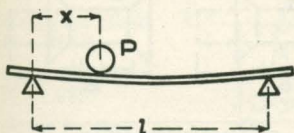

SIMPLE BEAM SINGLE CONCENTRATED MOVING LOAD

Maximum shear = P occurs at end for $x = 0$

Maximum bending moment = $\frac{Pl}{4}$ occurs at center for $x = \frac{l}{2}$

SIMPLE BEAM TWO EQUAL CONCENTRATED MOVING LOADS

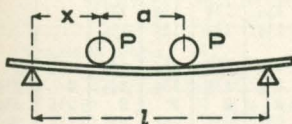

Maximum shear = $\frac{2P}{l} (l - \frac{a}{2})$ occurs at end for $x = 0$

Maximum bending moment

$M = \frac{P}{2l} (l - \frac{a}{2})^2$ occurs under load at distance $x = \frac{1}{2} (l - \frac{a}{2})$ from support

If a is greater than $0.586l$, preceding case will give maximum moment

SIMPLE BEAM TWO UNEQUAL CONCENTRATED MOVING LOADS

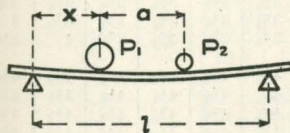

Maximum shear = $P_1 + P_2 \frac{l-a}{l}$ occurs at end for $x = 0$

Maximum bending moment = $(P_1 + P_2) \frac{x^2}{l}$ occurs under P at distance

$x = \frac{1}{2} (l + \frac{P_2 a}{P_1 + P_2})$ from left support

Maximum moment may occur for one load, as in case of single conc. mov. load

GENERAL RULES FOR MAXIMUM SHEARS AND MOMENTS IN SIMPLE BEAMS CARRYING MOVING CONCENTRATED LOADS

The maximum shear due to moving concentrated loads always occurs at a support when a certain load is near that support. The maximum shear there equals the total reaction. The maximum bending moment due to moving concentrated loads occurs under one of the loads when this load is as far from one support as the center of gravity of all the loads on the beam is from the other support.

DIMENSIONS AND WEIGHTS OF RIVETS

DIMENSIONS OF RIVET HEADS (DRIVEN)

FORMULAS

Diam. Head
 $B = 1.5D + \frac{1}{8}$

Height of Head
 $H = .425B$

Long Radius
 $R = 1.5H$

Short Radius
 $= H$

Depth of
 Countersink
 $K = .5D$

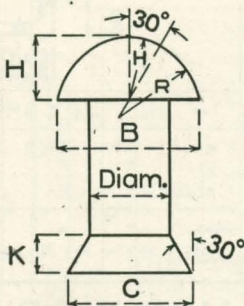

Diam. of Rivet	BUTTON HEAD			COUNTER-SINK	
	Diam. B	Height H	Radius R	Diam. C	Height K
$\frac{3}{8}$	$\frac{11}{16}$	$\frac{5}{16}$	$\frac{7}{16}$	$\frac{9}{16}$	$\frac{3}{16}$
$\frac{1}{2}$	$\frac{7}{8}$	$\frac{3}{8}$	$\frac{9}{16}$	$\frac{3}{4}$	$\frac{1}{4}$
$\frac{5}{8}$	$\frac{11}{16}$	$\frac{7}{16}$	$\frac{11}{16}$	1	$\frac{5}{16}$
$\frac{3}{4}$	$1\frac{1}{4}$	$\frac{1}{2}$	$\frac{13}{16}$	$1\frac{3}{16}$	$\frac{3}{8}$
$\frac{7}{8}$	$1\frac{1}{16}$	$\frac{5}{8}$	$\frac{15}{16}$	$1\frac{3}{8}$	$\frac{7}{16}$
1	$1\frac{5}{8}$	$\frac{11}{16}$	1	$1\frac{9}{16}$	$\frac{1}{2}$
$1\frac{1}{8}$	$1\frac{13}{16}$	$\frac{3}{4}$	$1\frac{1}{8}$	$1\frac{3}{4}$	$\frac{9}{16}$
$1\frac{1}{4}$	$1\frac{1}{4}$	$\frac{7}{8}$	$1\frac{1}{4}$	2	$\frac{5}{8}$
$1\frac{3}{8}$	$2\frac{3}{16}$	$\frac{15}{16}$	$1\frac{3}{8}$	$2\frac{3}{16}$	$1\frac{1}{16}$
$1\frac{1}{2}$	$2\frac{3}{8}$	1	$1\frac{1}{2}$	$2\frac{3}{8}$	$\frac{3}{4}$

WEIGHTS OF 100 BUTTON HEAD STEEL RIVETS

Length in Inches Under Head	DIAMETER OF RIVETS IN INCHES									
	$\frac{3}{8}$	$\frac{1}{2}$	$\frac{5}{8}$	$\frac{3}{4}$	$\frac{7}{8}$	1	$1\frac{1}{8}$	$1\frac{1}{4}$	$1\frac{3}{8}$	$1\frac{1}{2}$
1	4.8	10.0	17	28						
$1\frac{1}{4}$	5.6	11.4	20	31	44	60				
$1\frac{1}{2}$	6.4	12.7	22	34	48	65	87			
$1\frac{3}{4}$	7.2	14.1	24	37	52	70	93			
2	7.9	15.5	26	40	56	75	100	133	167	206
$2\frac{1}{4}$	8.7	16.9	28	43	60	81	107	141	177	218
$2\frac{1}{2}$	9.5	18.3	30	46	64	86	114	149	187	230
$2\frac{3}{4}$	10.3	19.7	33	49	69	91	120	158	197	242
3	11.1	21.0	35	52	73	96	127	166	208	254
$3\frac{1}{4}$	11.9	22.4	37	55	77	102	134	174	218	266
$3\frac{1}{2}$	12.6	23.8	39	58	81	107	141	183	228	278
$3\frac{3}{4}$	13.4	25.2	41	62	85	112	148	191	238	290
4		26.6	43	65	89	118	154	199	248	302
$4\frac{1}{4}$		28.0	46	68	93	123	161	208	258	314
$4\frac{1}{2}$		29.4	48	71	97	128	168	216	268	327
$4\frac{3}{4}$		30.7	50	74	101	133	175	224	278	339
5		32.1	52	77	105	139	181	233	288	351
$5\frac{1}{4}$			54	80	110	144	188	241	298	363
$5\frac{1}{2}$			56	83	114	149	195	249	308	375
$5\frac{3}{4}$			58	86	118	154	201	258	318	387
6			61	89	122	160	208	266	329	399
$6\frac{1}{2}$				95	130	170	222	283	349	423
7				102	138	181	235	300	369	447
$7\frac{1}{2}$				108	146	191	249	316	389	471
Weight of 100 Button Heads only	2.4	5.2	9	15	22.5	32.5	45.5	61	80	102

RIVETING DETAILS

DRIVING CLEARANCE			CRIMPS		GAUGES FOR ANGLES													
	Riv. Diam.	D	C	B = T + 1 1/2 (Min. 2'')														
	3/8	1 1/2	3/8			Leg	1 1/4	2	2 1/2	3	3 1/2	4	5	6	7	8		
	1/2	1 3/4	1			g ¹	1	1 1/8	1 3/8	1 3/4	2	2 1/2	3	3 1/2	4	4 1/2		
	5/8	2	1 1/8			g ²	2	2 1/2	2 1/2	2 1/2	3	3	
	3/4	2 1/4	1 1/4			g ³	1 3/4	2 1/4	2 1/4	3	3	3	
	7/8	2 1/2	1 3/8			Max. Riv.	1/2	5/8	3/4	7/8	7/8	7/8	7/8	7/8	1	1 1/8	1 1/8	1 1/8
	1	2 3/4	1 1/2															

MINIMUM PITCH FOR MACHINE RIVETING

	Riv. Diam. D	Std. C	Std. b	g													
				1 1/8	1 1/4	1 3/8	1 1/2	1 5/8	1 3/4	1 7/8	2	2 1/8	2 1/4	2 3/8	2 1/2	2 3/4	
				3/8	7/8	1 3/16	1/4	0
1/2	1	1 3/8	3/4	1/2	0
5/8	1 1/8	1 9/8	1 1/8	1	3/4	0
3/4	1 1/4	1 3/4	...	1 1/4	1 1/8	1	3/4	0
7/8	1 3/8	2	1 1/2	1 3/8	1 1/8	7/8	5/8	0
1	1 1/2	2 3/16	1 3/8	1 1/2	1 3/8	1 1/8	7/8	1/2	0
1 1/8	1 5/8	2 3/8	1 3/4	1 5/8	1 1/2	1 3/8	1 3/8	7/8	0
1 1/4	1 3/4	2 5/8	2	1 7/8	1 3/4	1 3/2	1 1/4	1	5/8	0
1 3/8	1 7/8	2 13/16	2 1/8	2	1 7/8	1 3/4	1 1/2	1 1/4	1 1/2	1 1/4	1 1/2
1 1/2	2	3	2 1/4	2 1/8	2	1 3/8	1 5/8	1 5/8	1 3/8	1 3/8

MINIMUM PITCH TO MAINTAIN 3 DIAMETERS C TO C

	Riv. Diam. D	Min. C to C b	g														
			1	1 1/4	1 1/2	1 3/4	2	2 1/4	2 1/2	2 3/4	3	3 1/4	3 1/2	3 3/4	4	4 1/4	
			3/8	1 1/8	1/2	0
1/2	1 1/2	1 1/8	7/8	0
5/8	1 3/8	1 5/8	1 3/8	1 1/8	5/8	0
3/4	2 1/4	2	1 7/8	1 9/8	1 3/8	1	0
7/8	2 5/8	2 1/2	2 3/8	2 1/8	2	1 3/4	1 3/8	3/4	0
1	3	2 7/8	2 3/4	2 5/8	2 1/2	2 1/4	2	1 5/8	1 1/2	0
1 1/8	3 3/8	3 1/4	3 1/8	3	2 7/8	2 3/4	2 1/2	2 1/4	2	1 1/2	7/8	0
1 1/4	3 3/4	3 5/8	3 1/2	3 3/8	3 3/8	3 1/4	3	2 3/4	2 1/2	2 1/4	1 7/8	1 3/8	0
1 3/8	4 1/8	4	4	3 7/8	3 3/4	3 3/8	3 1/2	3 1/4	3 3/8	2 7/8	2 1/2	2 1/8	1 3/4	1	0
1 1/2	4 1/2	4 3/8	4 3/8	4 1/4	4 1/8	4	3 7/8	3 3/4	3 1/2	3 3/8	2 7/8	2 1/2	2 1/2	2	1 1/2	1 1/2	1 1/2

DISTANCE CENTER TO CENTER OF STAGGERED RIVETS

Value of x for Varying Values of g and p

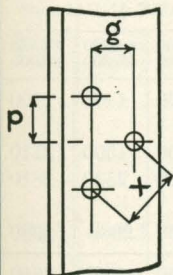

p In.	g, Inches													
	7/8	1	1 1/8	1 1/4	1 3/8	1 1/2	1 5/8	1 3/4	1 7/8	2	2 1/8	2 1/4	2 3/8	2 1/2
1 1/8	1 7/16	1 1/2	1 9/16	1 11/16	1 3/4	1 7/8	2	2 1/16	2 3/16	2 5/16	2 3/8	2 1/2	2 5/8	2 3/4
1 1/4	1 9/16	1 5/8	1 11/16	1 3/4	1 7/8	1 15/16	2 1/16	2 1/8	2 3/8	2 1/2	2 3/8	2 7/16	2 11/16	2 13/16
1 3/8	1 5/8	1 11/16	1 3/4	1 7/8	1 15/16	2	2 1/8	2 3/16	2 5/16	2 7/16	2 1/2	2 5/8	2 3/4	2 7/8
1 1/2	1 3/4	1 13/16	1 7/8	1 15/16	2	2 1/8	2 3/16	2 5/16	2 3/8	2 1/2	2 5/8	2 11/16	2 13/16	2 15/16
1 5/8	1 7/8	1 7/8	2	2 1/16	2 1/8	2 3/16	2 1/16	2 3/8	2 1/2	2 3/8	2 7/16	2 11/16	2 3/4	2 7/8
1 3/4	1 15/16	2	2 1/16	2 3/16	2 5/16	2 3/8	2 1/16	2 3/8	2 7/16	2 9/16	2 5/8	2 3/4	2 7/8	2 15/16
1 7/8	2 1/16	2 1/8	2 3/16	2 1/4	2 5/16	2 3/8	2 1/2	2 9/16	2 5/8	2 3/4	2 13/16	2 15/16	3	3 1/8
2	2 3/16	2 1/4	2 5/16	2 3/8	2 7/16	2 1/2	2 9/16	2 5/8	2 3/4	2 13/16	2 15/16	3	3 1/8	3 3/16
2 1/8	2 5/16	2 3/8	2 7/16	2 1/2	2 5/8	2 3/4	2 13/16	2 15/16	3	3 1/8	3 3/16	3 1/4	3 5/16	3 3/4
2 1/4	2 7/16	2 1/2	2 5/8	2 3/4	2 13/16	2 3/4	2 7/8	2 15/16	3	3 1/8	3 3/16	3 1/4	3 5/16	3 3/4
2 3/8	2 9/16	2 5/8	2 3/4	2 13/16	2 3/4	2 15/16	3	3 1/8	3 3/16	3 1/4	3 5/16	3 3/4	3 7/8	3 7/16
2 1/2	2 5/8	2 11/16	2 3/4	2 13/16	2 7/8	2 15/16	3	3 1/8	3 3/16	3 1/4	3 5/16	3 3/4	3 7/8	3 7/16

Values below and to right of upper zigzag line are large enough for 3/4 rivets.
 Values below and to right of lower zigzag line are large enough for 7/8 rivets.

CONVENTIONAL SIGNS FOR RIVETING

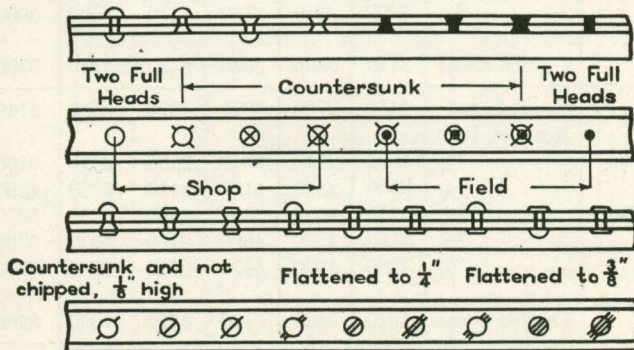

STAGGER OF RIVETS TO MAINTAIN NET SECTION

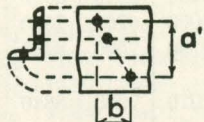
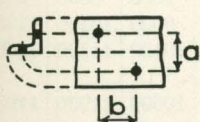

5/8" rivets can be taken at 1/8" less than for 3/4"
 1" " " " " " 1/8" more " " 7/8"

Dimensions in Inches

a	3/4 Rivet	7/8 Rivet	a'	3/4 Rivet	7/8 Rivet
	b	b		b	b
1	1 5/8	1 3/4	5	3 1/16	3 3/16
1 1/2	1 7/8	2	5 1/2	3 1/4	3 1/2
2	2 1/8	2 1/4	6	3 3/8	3 5/8
2 1/2	2 1/4	2 5/8	6 1/2	3 1/2	3 3/4
3	2 3/4	2 3/8	7	3 5/8	3 7/8
3 1/2	2 9/16	2 13/16	7 1/2	3 3/4	4
4	2 13/16	3	8	3 7/8	4 1/8
4 1/2	2 15/16	3 3/16	8 1/2	4	4 1/4

SHEARING AND BEARING VALUES OF RIVETS IN POUNDS

Size of Rivet, Inch	Area of Rivet, Square Inch	UNIT STRESSES, POUNDS PER SQUARE INCH							
		Shearing Bearing	8,000 16,000	9,000 18,000	10,000 20,000	11,000 22,000	12,000 24,000	13,500 27,000	13,500 30,000
$\frac{3}{8}$.1104	Single Shear Bearing, Inch	880	990	1100	1210	1320	1490	1490
		$\frac{3}{16}$	1130	1270	1410	1550	1690	1900	2110
		$\frac{1}{4}$	1500	1690	1880	2060	2250	2530	2810
		Double Shear	1770	1990	2210	2430	2650	2980	2980
$\frac{1}{2}$.1963	Single Shear Bearing, Inch	1570	1770	1960	2160	2360	2650	2650
		$\frac{3}{16}$	1500	1690	1880	2060	2250	2530	2810
		$\frac{1}{4}$	2000	2250	2500	2750	3000	3380	3750
		$\frac{5}{16}$	2500	2810	3130	3440	3750	4220	4690
		$\frac{3}{8}$	3000	3380	3750	4130	4500	5060	5630
		Double Shear	3140	3530	3930	4320	4710	5300	5300
$\frac{5}{8}$.3068	Single Shear Bearing, Inch	2450	2760	3070	3370	3680	4140	4140
		$\frac{3}{16}$	1880	2110	2340	2580	2810	3160	3520
		$\frac{1}{4}$	2500	2810	3130	3440	3750	4220	4690
		$\frac{5}{16}$	3130	3520	3910	4300	4690	5270	5860
		$\frac{3}{8}$	3750	4220	4690	5160	5630	6330	7030
		$\frac{1}{2}$	4380	4920	5470	6020	6560	7380	8200
$\frac{3}{4}$.4418	Single Shear Bearing, Inch	3530	3980	4420	4860	5300	5960	5960
		$\frac{1}{4}$	3000	3380	3750	4130	4500	5060	5630
		$\frac{5}{16}$	3750	4220	4690	5160	5630	6330	7030
		$\frac{3}{8}$	4500	5060	5630	6190	6750	7590	8440
		$\frac{1}{2}$	5250	5910	6560	7220	7880	8860	9840
		$\frac{1}{2}$	6000	6750	7500	8250	9000	10130	11250
		$\frac{3}{4}$	6750	7590	8440	9280	10130	11390	12660
		Double Shear	7070	7950	8840	9720	10600	11930	11930

**SHEARING AND BEARING
VALUES OF RIVETS
IN POUNDS**

Size of Rivet, Inch	Area of Rivet, Square Inch	UNIT STRESSES, POUNDS PER SQUARE INCH							
		Shearing Bearing	8,000 16,000	9,000 18,000	10,000 20,000	11,000 22,000	12,000 24,000	13,500 27,000	13,500 30,000
7/8	.6013	Single Shear Bearing, Inch	4810	5410	6010	6610	7220	8120	8120
		1/4	3500	3940	4380	4810	5250	5910	6560
		5/16	4380	4920	5470	6020	6560	7380	8200
		3/8	5250	5910	6560	7220	7880	8860	9840
		7/16	6130	6890	7660	8420	9190	10340	11480
		1/2	7000	7880	8750	9630	10500	11810	13130
		9/16	7880	8860	9840	10830	11810	13290	14770
		5/8	8750	9840	10940	12030	13130	14770	16410
		11/16	9630	10830	12030	13230	14440	16240	18050
		Double Shear	9620	10820	12030	13230	14430	16240	16240
1	.7854	Single Shear Bearing, Inch	6280	7070	7850	8640	9420	10600	10600
		1/4	4000	4500	5000	5500	6000	6750	7500
		5/16	5000	5630	6250	6880	7500	8440	9380
		3/8	6000	6750	7500	8250	9000	10130	11250
		7/16	7000	7880	8750	9630	10500	11810	13130
		1/2	8000	9000	10000	11000	12000	13500	15000
		9/16	9000	10130	11250	12380	13500	15190	16880
		5/8	10000	11250	12500	13750	15000	16880	18750
		11/16	11000	12380	13750	15130	16500	18560	20630
		3/4	12000	13500	15000	16500	18000	20250	22500
Double Shear	12570	14140	15710	17280	18850	21210	21210		
1 1/8	.9940	Single Shear Bearing, Inch	7950	8950	9940	10930	11930	13420	13420
		3/8	6750	7590	8440	9280	10130	11390	12660
		7/16	7880	8860	9840	10830	11810	13290	14770
		1/2	9000	10130	11250	12380	13500	15190	16880
		9/16	10130	11390	12660	13920	15190	17090	18980
		5/8	11250	12660	14060	15470	16880	18980	21090
		11/16	12380	13920	15470	17020	18560	20880	23200
		3/4	13500	15190	16880	18560	20250	22780	25310
Double Shear	15900	17890	19880	21870	23860	26840	26840		

STANDARD CAST IRON SEPARATORS FOR STANDARD AND PHOENIX BEAMS

Separators for 24" Beams are made of $\frac{5}{8}$ metal. All other Separators
are made of $\frac{1}{2}$ metal. All bolts $\frac{3}{4}$ " diameter

SEPARATORS WITH TWO BOLTS

DESIGNATION OF BEAM			DIS-TANCES		SEPA-RATORS	BOLTS		WEIGHTS				
Section Number	Depth, Inches	Weight, Pounds	O to O of Flanges of Beams, Inches	C to C of Beams, Inches		Length, Inches	Distance C to C of holes, Inches	Length, Inches	Bolts and Nuts, Pounds	Increase in Weight of Bolts for 1" Additional Spread of Beam, Pounds	Separator, Pounds	Increase in Weight of Separator for 1" Additional Spread of Beams, Pounds
208	24	79.9	14 $\frac{1}{4}$	7 $\frac{1}{4}$	6 $\frac{3}{4}$	13	8 $\frac{3}{4}$	2.92	.25	25.	3.25	27.92
	20	81.4	13 $\frac{3}{4}$	7	6 $\frac{3}{8}$	13	8 $\frac{5}{8}$	2.89	.25	16.	2.08	18.89
206	20	65.4	12 $\frac{3}{4}$	6 $\frac{1}{2}$	6	13	8	2.74	.25	15.	2.08	17.74
207	18	54.7	12 $\frac{1}{4}$	6 $\frac{1}{4}$	5 $\frac{3}{4}$	12	7 $\frac{3}{4}$	2.68	.25	14.	2.00	16.68
161	15	81.3	13 $\frac{3}{8}$	6 $\frac{3}{4}$	5 $\frac{7}{8}$	9	8 $\frac{1}{2}$	2.86	.25	12.	1.6	14.86
162	15	60.8	12 $\frac{1}{4}$	6 $\frac{1}{4}$	5 $\frac{5}{8}$	9	7 $\frac{7}{8}$	2.71	.25	11.5	1.6	14.21
164	15	42.9	11 $\frac{1}{4}$	5 $\frac{3}{4}$	5 $\frac{3}{8}$	9	7 $\frac{1}{8}$	2.53	.25	11.	1.6	13.53
252	15	36.0	11 $\frac{1}{4}$	5 $\frac{3}{4}$	5 $\frac{1}{2}$	9	7	2.50	.25	11.3	1.6	13.80
165	12	40.8	10 $\frac{3}{4}$	5 $\frac{1}{2}$	5	6 $\frac{1}{2}$	7	2.50	.25	8.5	1.2	11.00
166	12	31.8	10 $\frac{1}{4}$	5 $\frac{1}{4}$	4 $\frac{7}{8}$	6 $\frac{1}{2}$	6 $\frac{5}{8}$	2.41	.25	8.5	1.2	10.91
288	12	25.0	10 $\frac{1}{4}$	5 $\frac{1}{4}$	5	6 $\frac{1}{2}$	6 $\frac{1}{2}$	2.38	.25	8.5	1.2	10.88
221	10	25.4	9 $\frac{5}{8}$	5	4 $\frac{5}{8}$	5 $\frac{1}{2}$	6 $\frac{1}{4}$	2.30	.25	7.5	1.0	9.80
289	10	21.0	11 $\frac{3}{4}$	6	5 $\frac{3}{4}$	5 $\frac{1}{2}$	7 $\frac{1}{4}$	2.50	.25	8.6	1.0	11.10
209	9	21.8	8 $\frac{7}{8}$	4 $\frac{1}{2}$	4 $\frac{1}{4}$	4 $\frac{1}{2}$	5 $\frac{7}{8}$	2.21	.25	6.5	.88	8.71

SEPARATORS WITH ONE BOLT

210	8	18.4	8 $\frac{1}{4}$	4 $\frac{1}{4}$	4		5 $\frac{1}{2}$	1.06	.125	4.5	.78	5.56
298	8	17.0	10 $\frac{3}{4}$	5 $\frac{1}{2}$	5 $\frac{1}{4}$		6 $\frac{3}{4}$	1.22	.125	5.3	.78	6.52
211	7	15.3	7 $\frac{5}{8}$	4	3 $\frac{3}{4}$		5 $\frac{1}{4}$	1.03	.125	4.0	.65	5.03
212	6	12.5	7	3 $\frac{5}{8}$	3 $\frac{3}{8}$		4 $\frac{7}{8}$.99	.125	3.0	.50	3.99
214	5	10.0	6 $\frac{1}{4}$	3 $\frac{1}{4}$	3		4 $\frac{1}{2}$.94	.125	2.5	.40	3.44
213	4	7.7	5 $\frac{5}{8}$	3	2 $\frac{3}{4}$		4 $\frac{1}{8}$.89	.125	2.0	.30	2.89
222	3	5.7	5	2 $\frac{5}{8}$	2 $\frac{1}{2}$		3 $\frac{7}{8}$.87	.125	0.4	.15	1.27

3" Beam 1" Gas Pipe Separator

REDUCTION OF AREA FOR RIVET HOLES

Area in Square Inches = Diameter of Hole \times Thickness of Metal

Thick- ness of Metal, Inches	DIAMETER OF HOLE IN INCHES											
	$\frac{1}{16}$	$\frac{1}{8}$	$\frac{3}{16}$	$\frac{1}{4}$	$\frac{5}{16}$	$\frac{3}{8}$	$\frac{7}{16}$	$\frac{1}{2}$	$\frac{9}{16}$	1	$1\frac{1}{16}$	$1\frac{1}{8}$
$\frac{3}{16}$.08	.09	.11	.12	.13	.14	.15	.16	.18	.19	.20	.21
$\frac{1}{4}$.11	.13	.14	.16	.17	.19	.20	.22	.23	.25	.27	.28
$\frac{5}{16}$.14	.16	.18	.20	.21	.23	.25	.27	.29	.31	.33	.35
$\frac{3}{8}$.16	.19	.21	.23	.26	.28	.30	.33	.35	.38	.40	.42
$\frac{7}{16}$.19	.22	.25	.27	.30	.33	.36	.38	.41	.44	.46	.49
$\frac{1}{2}$.22	.25	.28	.31	.34	.38	.41	.44	.47	.50	.53	.56
$\frac{9}{16}$.25	.28	.32	.35	.39	.42	.46	.49	.53	.56	.60	.63
$\frac{5}{8}$.27	.31	.35	.39	.43	.47	.51	.55	.59	.63	.66	.70
$\frac{11}{16}$.30	.34	.39	.43	.47	.52	.56	.60	.64	.69	.73	.77
$\frac{3}{4}$.33	.38	.42	.47	.52	.56	.61	.66	.70	.75	.80	.84
$\frac{13}{16}$.36	.41	.46	.51	.56	.61	.66	.71	.76	.81	.86	.91
$\frac{7}{8}$.38	.44	.49	.55	.60	.66	.71	.77	.82	.88	.93	.98
$\frac{15}{16}$.41	.47	.53	.59	.64	.70	.76	.82	.88	.94	1.00	1.05
1	.44	.50	.56	.63	.69	.75	.81	.88	.94	1.00	1.06	1.13
$1\frac{1}{16}$.46	.53	.60	.66	.73	.80	.86	.93	1.00	1.06	1.13	1.20
$1\frac{1}{8}$.49	.56	.63	.70	.77	.84	.91	.98	1.05	1.13	1.20	1.27
$1\frac{3}{16}$.52	.59	.67	.74	.82	.89	.96	1.04	1.11	1.19	1.26	1.34
$1\frac{1}{4}$.55	.63	.70	.78	.86	.94	1.02	1.09	1.17	1.25	1.33	1.41
$1\frac{5}{16}$.57	.66	.74	.82	.90	.98	1.07	1.15	1.23	1.31	1.39	1.48
$1\frac{3}{8}$.60	.69	.77	.86	.95	1.03	1.12	1.20	1.29	1.38	1.46	1.55
$1\frac{7}{16}$.63	.72	.81	.90	.99	1.08	1.17	1.26	1.35	1.44	1.53	1.62
$1\frac{1}{2}$.66	.75	.84	.94	1.03	1.13	1.22	1.31	1.41	1.50	1.59	1.69

BOLT HEADS & NUTS
U. S. STANDARD DIMENSIONS

Diameter of Bolt	HEAD					NUT		Diameter of Bolt	WEIGHT OF ONE NUT			
	Hexagonal		Hex. or Square	Square		Hex. or Square	Other Dimensions same as Head		Hexagonal		Square	
	Long	Short	Height	Long	Short	Height			Tapped	Blank	Tapped	Blank
1/4	5/8	1/2	1/4	11/16	1/2	1/4	1/4	.012	.012	.013	.014	
3/8	13/16	11/16	3/8	1	11/16	3/8	3/8	.032	.033	.036	.038	
1/2	1	7/8	7/8	1 1/4	7/8	1/2	1/2	.066	.070	.076	.080	
5/8	1 1/4	1 1/16	9/16	1 1/2	1 1/16	5/8	5/8	.119	.127	.138	.145	
3/4	1 7/16	1 1/4	5/8	1 13/16	1 1/4	3/4	3/4	.194	.206	.225	.237	
7/8	1 11/16	1 7/16	3/4	2 1/16	1 7/16	7/8	7/8	.295	.313	.343	.361	
1	1 7/8	1 5/8	13/16	2 5/16	1 5/8	1	1	.427	.453	.497	.523	
1 1/8	2 1/8	1 13/16	15/16	2 9/16	1 13/16	1 1/8	1 1/8	.594	.632	.692	.730	
1 1/4	2 5/16	2	1	2 13/16	2	1 1/4	1 1/4	.793	.840	.926	.973	
1 3/8	2 9/16	2 3/16	1 1/8	3 1/8	2 9/16	1 3/8	1 3/8	1.042	1.108	1.218	1.283	
1 1/2	2 3/4	2 3/8	1 3/16	3 3/8	2 3/8	1 1/2	1 1/2	1.326	1.406	1.553	1.632	
1 5/8	3	2 9/16	1 5/16	3 5/8	2 9/16	1 5/8	1 5/8	1.666	1.766	1.952	2.052	
1 3/4	3 3/16	2 3/4	1 3/8	3 7/8	2 3/4	1 3/4	1 3/4	2.075	2.194	2.419	2.548	
1 7/8	3 7/16	2 15/16	1 1/2	4 3/16	2 15/16	1 7/8	1 7/8	2.505	2.653	2.939	3.088	
2	3 5/8	3 1/8	1 9/16	4 7/16	3 1/8	2	2	3.025	3.213	3.550	3.737	
2 1/4	4 1/16	3 1/2	1 3/4	4 15/16	3 1/2	2 1/4	2 1/4	4.221	4.464	4.963	5.207	
2 1/2	4 1/2	3 7/8	1 15/16	5 1/2	3 7/8	2 1/2	2 1/2	5.726	6.058	6.738	7.070	
2 3/4	4 15/16	4 1/4	2 1/8	6	4 1/4	2 3/4	2 3/4	7.421	7.909	8.307	8.795	
3	5 3/8	4 5/8	2 5/16	6 9/16	4 5/8	3	3	10.076	10.626	10.817	11.366	
3 1/4	5 13/16	5	2 1/2	7 1/16	5	3 1/4	3 1/4	11.957	12.709			
3 1/2	6 1/4	5 3/8	2 11/16	7 5/8	5 3/8	3 1/2	3 1/2	14.854	15.933			
4	7 1/16	6 1/8	3 1/16	8 11/16	6 1/8	4	4	21.838	23.199			

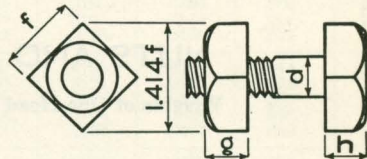
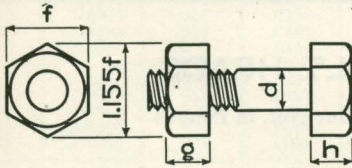

Rough Nut		Finished Nut		Rough Head		Finished Head	
f	g	f	g	f	h	f	h
1.5d + 1/8"	d	1.5d + 1/16"	d - 1/16"	1.5d + 1/8"	0.5f	1.5d + 1/16"	0.5f - 1/16"

United States Standard is also known as Franklin Institute Standard

WEIGHTS OF BOLTS WITH NUTS

U. S. STANDARD

Weight in Pounds per 100 Bolts

Length of Bolt	SQUARE HEADS AND NUTS							HEXAGON HEADS AND NUTS						
	½	⅝	¾	⅞	1	1¼	1½	½	⅝	¾	⅞	1	1¼	1½
1	22	37	56					19	33	52				
1¼	23	39	59					20	34	54				
1½	24	41	62					22	36	57				
1¾	26	43	64					23	38	60				
2	27	45	67	101	144			24	40	63	93	132		
2¼	28	47	71	104	150			26	43	66	97	137		
2½	30	49	74	109	155			27	45	69	101	143		
2¾	31	51	77	113	161			29	47	72	105	148		
3	33	54	80	117	167	309	501	30	49	75	109	154	277	445
3½	35	58	86	126	178	327	526	33	54	82	118	165	295	470
4	38	62	92	134	189	344	551	35	58	88	126	176	312	495
4½	41	66	98	142	198	361	576	38	62	94	134	186	329	520
5	43	71	104	151	209	379	601	41	66	100	143	197	347	545
5½	46	75	111	159	220	396	626	44	71	106	151	208	364	570
6	49	79	117	168	232	413	651	46	75	112	160	219	382	595
6½	52	84	123	176	243	431	676	49	79	119	168	230	399	620
7	55	88	129	185	254	448	701	52	84	125	177	241	416	645
7½	57	92	136	193	265	466	727	55	88	131	185	252	434	671
8	60	97	142	202	276	483	752	58	92	137	194	264	451	696
9	65	105	154	218	298	518	802	63	100	149	210	285	486	746
10	71	114	167	235	320	553	852	68	109	162	227	307	521	796
12	82	131	192	269	364	622	952	80	127	187	261	352	590	896
14	93	148	217	303	409	692	1052	91	144	212	295	396	660	996
Per 1" Addition	5.6	8.7	12.5	17.0	22.3	34.8	50.1	5.6	8.7	12.5	17.0	22.3	34.8	50.1

NUTS AND BOLT HEADS

Weights of One Head and One Nut, in Pounds

Diameter of Bolt	1¼	1½	1¾	2	2½	3
Square Head and Nut,	2.05	3.51	5.48	8.08	15.5	26.2
Hexagon Head and Nut	1.73	2.95	4.61	6.79	13.0	22.0
Weight of Shank, per inch	.3477	.5007	.6815	.8900	1.391	2.003

WIRE AND SHEET METAL GAUGES

In Decimals of an Inch

No. of Gauge	American or Brown & Sharpe Wire Gauge	Birmingham or Stubbs Iron Wire Gauge (B. W. G.)	United States Standard Gauge for Sheet Steel	John A. Roebbing's Sons Co. American Steel & Wire Co. formerly Washburn & Moen	British Imperial or English Legal Standard Wire Gauge	New Birmingham Standard Sheet & Hoop Gauge (B. G.)	Music Wire Gauge	No. of Gauge
7/0's			.4902		.500	.6666		7/0's
6/0's			.4596	.4600	.464	.625		6/0's
5/0's			.4289	.4300	.432	.5883		5/0's
4/0's	.460000	.454	.3983	.3938	.400	.5416		4/0's
3/0's	.409642	.425	.3676	.3625	.372	.500		3/0's
2/0's	.364796	.380	.3370	.3310	.348	.4452	.0085	2/0's
0	.324861	.340	.3064	.3065	.324	.3964	.009	0
1	.289297	.300	.2758	.2830	.300	.3532	.010	1
2	.257627	.284	.2604	.2625	.276	.3147	.011	2
3	.229423	.259	.2451	.2437	.252	.2804	.012	3
4	.204307	.238	.2298	.2253	.232	.250	.013	4
5	.181940	.220	.2145	.2070	.212	.2225	.014	5
6	.162023	.203	.1992	.1920	.192	.1981	.016	6
7	.144285	.180	.1838	.1770	.176	.1764	.018	7
8	.128490	.165	.1685	.1620	.160	.1570	.020	8
9	.114423	.148	.1532	.1483	.144	.1398	.022	9
10	.101897	.134	.1379	.1350	.128	.1250	.024	10
11	.090742	.120	.1226	.1205	.116	.1113	.026	11
12	.080808	.109	.1072	.1055	.104	.0991	.028	12
13	.071962	.095	.0919	.0915	.092	.0882	.030	13
14	.064084	.083	.0766	.0800	.080	.0785	.032	14
15	.057068	.072	.0689	.0720	.072	.0699	.034	15
16	.050821	.065	.0613	.0625	.064	.0625	.036	16
17	.045257	.058	.0552	.0540	.056	.0556	.038	17
18	.040303	.049	.0490	.0475	.048	.0495	.040	18
19	.035890	.042	.0429	.0410	.040	.0440	.042	19
20	.031961	.035	.0368	.0348	.036	.0392	.044	20
21	.028462	.032	.0337	.03175	.032	.0349	.046	21
22	.025346	.028	.0306	.0286	.028	.0313	.048	22
23	.022572	.025	.0276	.0258	.024	.0278	.051	23
24	.020101	.022	.0245	.0230	.022	.0248	.055	24
25	.017900	.020	.0214	.0204	.020	.0220	.059	25
26	.015941	.018	.0184	.0181	.018	.0196	.063	26
27	.014195	.016	.0169	.0173	.0164	.0175	.067	27
28	.012641	.014	.0153	.0162	.0148	.0156	.071	28
29	.011257	.013	.0138	.0150	.0136	.0139	.074	29
30	.010025	.012	.0123	.0140	.0124	.0123	.078	30
31	.008928	.010	.0107	.0132	.0116	.0110	.082	31
32	.007950	.009	.0100	.0128	.0108	.0098	.086	32
33	.007080	.008	.0092	.0118	.0100	.0087	.090	33
34	.006305	.007	.0084	.0104	.0092	.0077	.095	34
35	.005615	.005	.0077	.0095	.0084	.0069	.100	35
36	.005000	.004	.0069	.0090	.0076	.0061	.105	36
37	.004453		.0065	.0085	.0068	.0054	.110	37
38	.003965		.0061	.0080	.0060	.0048	.115	38
39	.003531		.0057	.0075	.0052	.0043	.120	39
40	.003144		.0054	.0070	.0048	.0039	.125	40
41							.130	41

UPSET SCREW ENDS FOR SQUARE BARS

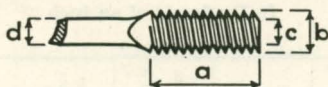

BAR			UPSET					
Side of Square d, Inches	Area, Sq. Inches	Weight per Foot, Lbs.	Diameter b, Inches	Length a, Inches	Additional Length for Upset + 10%, Inches	Diameter at Root of Thread c, Inches	Area	
							At Root of Thread, Sq. Inches	Excess over Area of Bar, %
$\frac{3}{4}$	0.563	1.91	$1\frac{1}{8}$	4	4	0.939	0.693	23.2
$\frac{7}{8}$	0.766	2.60	$1\frac{1}{4}$	4	$3\frac{1}{2}$	1.064	0.890	16.2
1	1.000	3.40	$1\frac{1}{2}$	4	4	1.283	1.294	29.4
$1\frac{1}{8}$	1.266	4.30	$1\frac{5}{8}$	4	$3\frac{1}{2}$	1.389	1.515	19.7
$1\frac{1}{4}$	1.563	5.31	$1\frac{7}{8}$	$4\frac{1}{2}$	$4\frac{1}{2}$	1.615	2.049	31.1
$1\frac{3}{8}$	1.891	6.43	2	$4\frac{1}{2}$	4	1.711	2.300	21.7
$1\frac{1}{2}$	2.250	7.65	$2\frac{1}{4}$	5	5	1.961	3.021	34.3
$1\frac{5}{8}$	2.641	8.98	$2\frac{3}{8}$	5	$4\frac{1}{2}$	2.086	3.419	29.5
$1\frac{3}{4}$	3.063	10.41	$2\frac{1}{2}$	$5\frac{1}{2}$	$4\frac{1}{2}$	2.175	3.716	21.3
$1\frac{7}{8}$	3.516	11.95	$2\frac{3}{4}$	$5\frac{1}{2}$	5	2.425	4.619	31.4
2	4.000	13.60	$2\frac{7}{8}$	6	5	2.550	5.108	27.7
$2\frac{1}{8}$	4.516	15.35	3	6	$4\frac{1}{2}$	2.629	5.428	20.2
$2\frac{1}{4}$	5.063	17.21	$3\frac{1}{4}$	$6\frac{1}{2}$	$5\frac{1}{2}$	2.879	6.509	28.6
$2\frac{3}{8}$	5.641	19.18	$3\frac{1}{2}$	7	$6\frac{1}{2}$	3.100	7.549	33.8
$2\frac{1}{2}$	6.250	21.25	$3\frac{3}{4}$	7	7	3.317	8.641	38.3
$2\frac{5}{8}$	6.891	23.43	$3\frac{3}{4}$	7	$5\frac{1}{2}$	3.317	8.641	25.4
$2\frac{3}{4}$	7.563	25.71	4	$7\frac{1}{2}$	$6\frac{1}{2}$	3.567	9.993	32.1
$2\frac{7}{8}$	8.266	28.10	$4\frac{1}{4}$	8	$7\frac{1}{2}$	3.798	11.330	37.1
3	9.000	30.60	$4\frac{1}{4}$	8	6	3.798	11.330	25.9
$3\frac{1}{8}$	9.766	33.20	$4\frac{1}{2}$	$8\frac{1}{2}$	7	4.028	12.741	30.5
$3\frac{1}{4}$	10.563	35.91	$4\frac{3}{4}$	$8\frac{1}{2}$	$7\frac{1}{2}$	4.255	14.221	34.6

Horizontal or Vertical Cotter Pin Finished

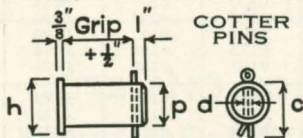

Horizontal Cotter Pin Over 2" Finished

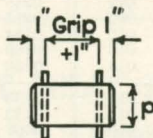

Pin	Head	Cotter		Pin	Head	Cotter	
		c	d			c	d
$1\frac{1}{4}$	$1\frac{1}{2}$	2	$\frac{1}{4}$	$2\frac{3}{4}$	$3\frac{1}{8}$	4	$\frac{3}{8}$
$1\frac{1}{2}$	$1\frac{3}{4}$	$2\frac{1}{2}$	$\frac{1}{4}$	3	$3\frac{1}{2}$	5	$\frac{1}{2}$
$1\frac{3}{4}$	2	$2\frac{3}{4}$	$\frac{1}{4}$	$3\frac{1}{4}$	$3\frac{3}{4}$	5	$\frac{1}{2}$
2	$2\frac{3}{8}$	3	$\frac{3}{8}$	$3\frac{1}{2}$	4	6	$\frac{1}{2}$
$2\frac{1}{4}$	$2\frac{5}{8}$	$3\frac{1}{4}$	$\frac{3}{8}$	$3\frac{3}{4}$	$4\frac{1}{4}$	6	$\frac{1}{2}$
$2\frac{1}{2}$	$2\frac{7}{8}$	$3\frac{3}{4}$	$\frac{3}{8}$				

UPSET SCREW ENDS FOR ROUND BARS

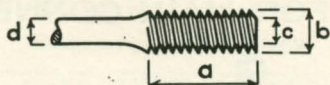

BAR			UPSET					
Diameter d, Inches	Area, Sq. Inches	Weight per Foot, Lbs.	Diameter b, Inches	Length a, Inches	Additional Length for Upset + 10%, Inches	Diameter at Root of Thread c, Inches	Area	
							At Root of Thread, Sq. Inches	Excess over Area of Bar, %
$\frac{3}{4}$	0.442	1.50	1	4	4	0.838	0.551	24.7
$\frac{7}{8}$	0.601	2.04	$1\frac{1}{4}$	4	5	1.064	0.890	48.0
1	0.785	2.67	$1\frac{3}{8}$	4	4	1.158	1.054	34.2
$1\frac{1}{8}$	0.994	3.38	$1\frac{1}{2}$	4	4	1.283	1.294	30.2
$1\frac{1}{4}$	1.227	4.17	$1\frac{5}{8}$	4	4	1.389	1.515	23.5
$1\frac{3}{8}$	1.485	5.05	$1\frac{3}{4}$	4	4	1.490	1.744	17.5
$1\frac{1}{2}$	1.767	6.01	2	$4\frac{1}{2}$	$4\frac{1}{2}$	1.711	2.300	30.2
$1\frac{5}{8}$	2.074	7.05	$2\frac{1}{8}$	$4\frac{1}{2}$	4	1.836	2.649	27.7
$1\frac{3}{4}$	2.405	8.18	$2\frac{1}{4}$	5	4	1.961	3.021	25.6
$1\frac{7}{8}$	2.761	9.39	$2\frac{3}{8}$	5	4	2.086	3.419	23.8
2	3.142	10.68	$2\frac{1}{2}$	$5\frac{1}{2}$	4	2.175	3.716	18.3
$2\frac{1}{8}$	3.547	12.06	$2\frac{5}{8}$	$5\frac{1}{2}$	$3\frac{1}{2}$	2.300	4.156	17.2
$2\frac{1}{4}$	3.976	13.52	$2\frac{7}{8}$	6	$4\frac{1}{2}$	2.550	5.108	28.4
$2\frac{3}{8}$	4.430	15.06	3	6	$4\frac{1}{2}$	2.629	5.428	22.5
$2\frac{1}{2}$	4.909	16.69	$3\frac{1}{4}$	$6\frac{1}{2}$	$5\frac{1}{2}$	2.879	6.509	32.6
$2\frac{5}{8}$	5.412	18.40	$3\frac{1}{4}$	$6\frac{1}{2}$	$4\frac{1}{2}$	2.879	6.509	20.3
$2\frac{3}{4}$	5.940	20.19	$3\frac{1}{2}$	7	$5\frac{1}{2}$	3.100	7.549	27.1
$2\frac{7}{8}$	6.492	22.07	$3\frac{3}{4}$	7	6	3.317	8.641	33.1
3	7.069	24.03	$3\frac{3}{4}$	7	5	3.317	8.641	22.2
$3\frac{1}{8}$	7.670	26.08	4	$7\frac{1}{2}$	6	3.567	9.993	30.3
$3\frac{1}{4}$	8.296	28.21	4	$7\frac{1}{2}$	5	3.567	9.993	20.5
$3\frac{3}{8}$	8.946	30.42	$4\frac{1}{4}$	8	$5\frac{1}{2}$	3.798	11.330	26.6
$3\frac{1}{2}$	9.621	32.71	$4\frac{1}{4}$	8	5	3.798	11.330	17.8
$3\frac{5}{8}$	10.321	35.09	$4\frac{1}{2}$	$8\frac{1}{2}$	$5\frac{1}{2}$	4.028	12.741	23.4
$3\frac{3}{4}$	11.045	37.55	$4\frac{3}{4}$	$8\frac{1}{2}$	6	4.255	14.221	28.8
$3\frac{7}{8}$	11.793	40.10	$4\frac{3}{4}$	$8\frac{1}{2}$	$5\frac{1}{2}$	4.255	14.221	20.6

TABLE OF STANDARD PIN NUTS AND PILOTS FOR MAIN CONNECTIONS

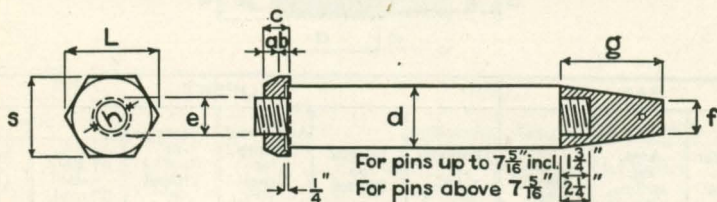

Mark of Pin Nut and Pilot	Diameter of Pin, Inches	Diameter of Hole, Inches	Diameter of Thread, Inches	Short Diam. of Nut, Inches	Long Diam. of Nut, Inches	Depth of Nut, Inches	Thickness of Metal of Nut, Inches	Depth of Recess, Inches	Weight of One Nut	PILOT			
										Diam. at Shoulder, Inches	Weight in Pounds	Diam. at Point, Inches	Length Over All, Inches
	d	h	e	s	L	c	a	b		d	f	g	
P1	$2\frac{7}{16}$	$1\frac{1}{2}$	$1\frac{5}{8}$	$3\frac{5}{8}$	$4\frac{3}{16}$	$1\frac{1}{2}$	1	$\frac{1}{2}$	2.5	$2\frac{7}{16}$	4.0	$1\frac{1}{16}$	$4\frac{7}{16}$
P2	$2\frac{15}{16}$	$1\frac{3}{4}$	$1\frac{7}{8}$	$4\frac{1}{8}$	$4\frac{3}{4}$	$1\frac{1}{2}$	1	$\frac{1}{2}$	2.8	$2\frac{15}{16}$	6.5	$2\frac{1}{16}$	$4\frac{15}{16}$
P3	$3\frac{7}{16}$	$2\frac{1}{4}$	$2\frac{3}{8}$	$4\frac{5}{8}$	$5\frac{3}{8}$	$1\frac{1}{2}$	1	$\frac{1}{2}$	3.3	$3\frac{7}{16}$	10.0	$2\frac{7}{16}$	$5\frac{7}{16}$
P4	$3\frac{15}{16}$	$2\frac{1}{2}$	$2\frac{5}{8}$	$5\frac{1}{8}$	$5\frac{15}{16}$	$1\frac{1}{2}$	1	$\frac{1}{2}$	4.7	$3\frac{15}{16}$	15.0	$2\frac{15}{16}$	$5\frac{15}{16}$
P5	$4\frac{3}{16}$	$2\frac{3}{4}$	$2\frac{7}{8}$	$5\frac{1}{2}$	$6\frac{3}{8}$	$1\frac{1}{2}$	1	$\frac{1}{2}$	4.9	$4\frac{3}{16}$	18.0	$3\frac{1}{16}$	$6\frac{3}{16}$
P6	$4\frac{11}{16}$	3	$3\frac{1}{8}$	$5\frac{7}{8}$	$6\frac{3}{4}$	$1\frac{1}{2}$	1	$\frac{1}{2}$	5.25	$4\frac{11}{16}$	22.0	$3\frac{7}{16}$	$6\frac{9}{16}$
P7	$4\frac{15}{16}$	$3\frac{1}{4}$	$3\frac{3}{8}$	$6\frac{1}{8}$	$7\frac{1}{16}$	$1\frac{1}{2}$	1	$\frac{1}{2}$	6.4	$4\frac{15}{16}$	26.5	$3\frac{7}{16}$	$6\frac{15}{16}$
P8	$5\frac{5}{16}$	$3\frac{1}{2}$	$3\frac{5}{8}$	$6\frac{1}{2}$	$7\frac{1}{2}$	$1\frac{1}{2}$	1	$\frac{1}{2}$	7.0	$5\frac{5}{16}$	29.5	$3\frac{13}{16}$	$7\frac{5}{16}$
P9	$5\frac{9}{16}$	$3\frac{3}{4}$	$3\frac{7}{8}$	$6\frac{3}{4}$	$7\frac{13}{16}$	$1\frac{1}{2}$	1	$\frac{1}{2}$	7.4	$5\frac{9}{16}$	34.0	$3\frac{13}{16}$	$7\frac{9}{16}$
P10	$5\frac{13}{16}$	$3\frac{3}{4}$	$3\frac{7}{8}$	7	$8\frac{1}{16}$	$1\frac{1}{2}$	1	$\frac{1}{2}$	7.4	$5\frac{13}{16}$	39.5	$4\frac{1}{16}$	$7\frac{13}{16}$
P11	$6\frac{3}{16}$	$4\frac{1}{4}$	$4\frac{3}{8}$	$7\frac{1}{2}$	$8\frac{11}{16}$	$1\frac{1}{2}$	1	$\frac{1}{2}$	7.5	$6\frac{3}{16}$	51.0	$4\frac{7}{16}$	$8\frac{5}{16}$
P12	$6\frac{11}{16}$	$4\frac{1}{2}$	$4\frac{5}{8}$	$7\frac{3}{8}$	$9\frac{1}{8}$	$1\frac{1}{2}$	1	$\frac{1}{2}$	7.6	$6\frac{11}{16}$	65.0	$4\frac{11}{16}$	$8\frac{11}{16}$
P13	$6\frac{15}{16}$	$4\frac{3}{4}$	$4\frac{7}{8}$	$8\frac{1}{8}$	$9\frac{3}{8}$	$1\frac{1}{2}$	1	$\frac{1}{2}$	8.0	$6\frac{15}{16}$	70.0	$4\frac{15}{16}$	$8\frac{13}{16}$
P14	$7\frac{1}{16}$	$4\frac{7}{8}$	$5\frac{1}{8}$	$8\frac{1}{2}$	$9\frac{13}{16}$	$1\frac{1}{2}$	1	$\frac{1}{2}$	8.5	$7\frac{1}{16}$	83.0	$5\frac{1}{16}$	$9\frac{5}{16}$
*P15	$7\frac{11}{16}$	$5\frac{1}{8}$	$5\frac{9}{8}$	9	$10\frac{3}{8}$	2	$1\frac{1}{4}$	$\frac{3}{4}$	19.0	$7\frac{11}{16}$	93.0	$5\frac{3}{16}$	$10\frac{1}{4}$
*P16	$8\frac{3}{8}$	$5\frac{5}{8}$	$5\frac{7}{8}$	$9\frac{11}{16}$	$11\frac{1}{16}$	2	$1\frac{1}{4}$	$\frac{3}{4}$	19.9	$8\frac{3}{8}$	116.0	$5\frac{1}{2}$	11
*P17	$8\frac{7}{8}$	$6\frac{1}{8}$	$6\frac{3}{8}$	$10\frac{1}{4}$	$11\frac{13}{16}$	2	$1\frac{1}{4}$	$\frac{3}{4}$	20.3	$8\frac{7}{8}$	134.0	$5\frac{7}{8}$	$11\frac{1}{2}$
*P18	$9\frac{3}{8}$	$6\frac{5}{8}$	$6\frac{7}{8}$	$10\frac{3}{4}$	$12\frac{1}{16}$	2	$1\frac{1}{4}$	$\frac{3}{4}$	21.3	$9\frac{3}{8}$	155.5	$6\frac{1}{4}$	12
*P19	10	$7\frac{1}{4}$	$7\frac{1}{2}$	$11\frac{3}{8}$	$13\frac{1}{8}$	2	$1\frac{1}{4}$	$\frac{3}{4}$	24.1	10	189.0	$6\frac{5}{8}$	$12\frac{5}{8}$
*P20	$10\frac{1}{2}$	$7\frac{3}{4}$	8	$11\frac{7}{8}$	$13\frac{11}{16}$	2	$1\frac{1}{4}$	$\frac{3}{4}$	25.0	$10\frac{1}{2}$	246.0	7	$13\frac{1}{8}$
*P21	11	$8\frac{1}{4}$	$8\frac{1}{2}$	$12\frac{3}{8}$	$14\frac{3}{8}$	2	$1\frac{1}{4}$	$\frac{3}{4}$	26.5	11	267.0	8	$13\frac{1}{2}$

* These Nuts are Steel Castings. The smaller Nuts are drop forged.

All pin nuts—8 threads per inch.

PINS

BEARING VALUES ON METAL ONE INCH THICK, IN POUNDS

Diameter \times 1 \times Unit Stress

PIN		FIBER STRESS IN POUNDS PER SQ. INCH						
Diam., Inches	Area, Sq. Inches	18000	20000	22000	24000	25000	27000	30000
1	.785	18000	20000	22000	24000	25000	27000	30000
1 $\frac{1}{4}$	1.227	22500	25000	27500	30000	31250	33750	37500
1 $\frac{1}{2}$	1.767	27000	30000	33000	36000	37500	40500	45000
1 $\frac{3}{4}$	2.405	31500	35000	38500	42000	43750	47250	52500
2	3.142	36000	40000	44000	48000	50000	54000	60000
2 $\frac{1}{4}$	3.976	40500	45000	49500	54000	56250	60750	67500
2 $\frac{1}{2}$	4.909	45000	50000	55000	60000	62500	67500	75000
2 $\frac{3}{4}$	5.940	49500	55000	60500	66000	68750	74250	82500
3	7.069	54000	60000	66000	72000	75000	81000	90000
3 $\frac{1}{4}$	8.296	58500	65000	71500	78000	81250	87750	97500
3 $\frac{1}{2}$	9.621	63000	70000	77000	84000	87500	94500	105000
3 $\frac{3}{4}$	11.045	67500	75000	82500	90000	93750	101250	112500
4	12.566	72000	80000	88000	96000	100000	108000	120000
4 $\frac{1}{4}$	14.186	76500	85000	93500	102000	106250	114750	127500
4 $\frac{1}{2}$	15.904	81000	90000	99000	108000	112500	121500	135000
4 $\frac{3}{4}$	17.721	85500	95000	104500	114000	118750	128250	142500
5	19.635	90000	100000	110000	120000	125000	135000	150000
5 $\frac{1}{4}$	21.648	94500	105000	115500	126000	131250	141750	157500
5 $\frac{1}{2}$	23.758	99000	110000	121000	132000	137500	148500	165000
5 $\frac{3}{4}$	25.967	103500	115000	126500	138000	143750	155250	172500
6	28.274	108000	120000	132000	144000	150000	162000	180000
6 $\frac{1}{4}$	30.680	112500	125000	137500	150000	156250	168750	187500
6 $\frac{1}{2}$	33.183	117000	130000	143000	156000	162500	175500	195000
6 $\frac{3}{4}$	35.785	121500	135000	148500	162000	168750	182250	202500
7	38.485	126000	140000	154000	168000	175000	189000	210000
7 $\frac{1}{4}$	41.282	130500	145000	159500	174000	181250	195750	217500
7 $\frac{1}{2}$	44.179	135000	150000	165000	180000	187500	202500	225000
7 $\frac{3}{4}$	47.173	139500	155000	170500	186000	193750	209250	232500
8	50.265	144000	160000	176000	192000	200000	216000	240000
8 $\frac{1}{4}$	53.456	148500	165000	181500	198000	206250	222750	247500
8 $\frac{1}{2}$	56.745	153000	170000	187000	204000	212500	229500	255000
8 $\frac{3}{4}$	60.132	157500	175000	192500	210000	218750	236250	262500
9	63.617	162000	180000	198000	216000	225000	243000	270000
9 $\frac{1}{4}$	67.201	166500	185000	203500	222000	231250	249750	277500
9 $\frac{1}{2}$	70.882	171000	190000	209000	228000	237500	256500	285000
9 $\frac{3}{4}$	74.662	175500	195000	214500	234000	243750	263250	292500
10	78.540	180000	200000	220000	240000	250000	270000	300000
10 $\frac{1}{4}$	82.516	184500	205000	225500	246000	256250	276750	307500
10 $\frac{1}{2}$	86.590	189000	210000	231000	252000	262500	283500	315000
10 $\frac{3}{4}$	90.763	193500	215000	236500	258000	268750	290250	322500
11	95.033	198000	220000	242000	264000	275000	297000	330000
11 $\frac{1}{4}$	99.402	202500	225000	247500	270000	281250	303750	337500
11 $\frac{1}{2}$	103.869	207000	230000	253000	276000	287500	310500	345000
11 $\frac{3}{4}$	108.434	211500	235000	258500	282000	293750	317250	352500
12	113.097	216000	240000	264000	288000	300000	324000	360000

RESISTING MOMENTS OF PINS

Diameter³ × 0.0982 × Unit Stress

Diameter of Pin in Inches	Area of Pin in Square Inches	MOMENTS IN INCH-POUNDS FOR FIBER STRESSES OF				
		15,000 lbs. per Sq. Inch	18,000 lbs. per Sq. Inch	20,000 lbs. per Sq. Inch	22,500 lbs. per Sq. Inch	25,000 lbs. per Sq. Inch
1	0.785	1470	1770	1960	2210	2450
1 1/8	0.994	2100	2520	2800	3140	3500
1 1/4	1.227	2880	3450	3830	4310	4790
1 3/8	1.485	3830	4590	5100	5740	6380
1 1/2	1.767	4970	5960	6630	7460	8280
1 5/8	2.074	6320	7580	8430	9480	10500
1 3/4	2.405	7890	9470	10500	11800	13200
1 7/8	2.761	9710	11600	12900	14600	16200
2	3.142	11800	14100	15700	17700	19600
2 1/8	3.547	14100	17000	18800	21200	23600
2 1/4	3.976	16800	20100	22400	25200	28000
2 3/8	4.430	19700	23700	26300	29600	32900
2 1/2	4.909	23000	27600	30700	34500	38400
2 5/8	5.412	26600	32000	35500	40000	44400
2 3/4	5.940	30600	36800	40800	45900	51000
2 7/8	6.492	35000	42000	46700	52500	58300
3	7.069	39800	47700	53000	59600	66300
3 1/8	7.670	44900	53900	59900	67400	74900
3 1/4	8.296	50600	60700	67400	75800	84300
3 3/8	8.946	56600	67900	75500	84900	94400
3 1/2	9.621	63100	75800	84200	94700	105200
3 5/8	10.321	70100	84200	93500	105200	116900
3 3/4	11.045	77700	93200	103500	116500	129400
3 7/8	11.793	85700	102800	114200	128500	142800
4	12.566	94200	113100	125700	141400	157100
4 1/8	13.364	103400	124000	137800	155000	172300
4 1/4	14.186	113000	135700	150700	169600	188400
4 3/8	15.033	123300	148000	164400	185000	205500
4 1/2	15.904	134200	161000	178900	201300	223700
4 5/8	16.800	145700	174800	194300	218500	242800
4 3/4	17.721	157800	189400	210400	236700	263000
4 7/8	18.665	170600	204700	227500	255900	284400
5	19.635	184100	220900	245400	276100	306800
5 1/8	20.629	198200	237900	264300	297300	330400
5 1/4	21.648	213100	255700	284100	319600	355200
5 3/8	22.691	228700	274400	304900	343000	381100
5 1/2	23.758	245000	294000	326700	367500	408300
5 5/8	24.850	262100	314500	349500	393100	436800
5 3/4	25.967	280000	335900	373300	419900	466600
5 7/8	27.109	298600	358300	398200	447900	497700

RESISTING MOMENTS OF PINS

Diameter³ × 0.0982 × Unit Stress

Diameter of Pin in Inches	Area of Pin in Square Inches	MOMENTS IN INCH-POUNDS FOR FIBER STRESSES OF				
		15,000	18,000	20,000	22,500	25,000
		lbs. per Sq. Inch	lbs. per Sq. Inch	lbs. per Sq. Inch	lbs. per Sq. Inch	lbs. per Sq. Inch
6	28.274	318100	381700	424100	477100	530200
6 $\frac{1}{8}$	29.465	338400	406100	451200	507600	564000
6 $\frac{1}{4}$	30.680	359500	431400	479400	539300	599200
6 $\frac{3}{8}$	31.919	381500	457800	508700	572300	635900
6 $\frac{1}{2}$	33.183	404400	485300	539200	606600	674000
6 $\frac{5}{8}$	34.472	428200	513800	570900	642300	713700
6 $\frac{3}{4}$	35.785	452900	543500	603900	679400	754800
6 $\frac{7}{8}$	37.122	478500	574200	638000	717800	797500
7	38.485	505100	606100	673500	757700	841900
7 $\frac{1}{8}$	39.871	532700	639200	710200	799000	887800
7 $\frac{1}{4}$	41.282	561200	673400	748200	841800	935300
7 $\frac{3}{8}$	42.718	590700	708900	787600	886100	984500
7 $\frac{1}{2}$	44.179	621300	745500	828400	931900	1035400
7 $\frac{5}{8}$	45.664	652900	783400	870500	979300	1088100
7 $\frac{3}{4}$	47.173	685500	822600	914000	1028200	1142500
7 $\frac{7}{8}$	48.707	719200	863000	958900	1078800	1198700
8	50.265	754000	904800	1005300	1131000	1256600
8 $\frac{1}{8}$	51.849	789900	947900	1053200	1184800	1316500
8 $\frac{1}{4}$	53.456	826900	992300	1102500	1240300	1378200
8 $\frac{3}{8}$	55.088	865100	1038100	1153400	1297600	1441800
8 $\frac{1}{2}$	56.745	904400	1085200	1205800	1356600	1507300
8 $\frac{5}{8}$	58.426	944900	1133800	1259800	1417300	1574800
8 $\frac{3}{4}$	60.132	986500	1183800	1315400	1479800	1644200
8 $\frac{7}{8}$	61.862	1029400	1235300	1372500	1544100	1715700
9	63.617	1073500	1288200	1431400	1610300	1789200
9 $\frac{1}{8}$	65.397	1118900	1342700	1491900	1678400	1864800
9 $\frac{1}{4}$	67.201	1165500	1398600	1554000	1748300	1942500
9 $\frac{3}{8}$	69.029	1213400	1456100	1617900	1820100	2022300
9 $\frac{1}{2}$	70.882	1262600	1515100	1683400	1893900	2104300
9 $\frac{5}{8}$	72.760	1313100	1575700	1750800	1969600	2188500
9 $\frac{3}{4}$	74.662	1364900	1637900	1819900	2047400	2274900
9 $\frac{7}{8}$	76.590	1418100	1701700	1890800	2127100	2363500
10	78.54	1472600	1767100	1963500	2208900	2454400
10 $\frac{1}{4}$	82.52	1585900	1903000	2114500	2378800	2643100
10 $\frac{1}{2}$	86.59	1704700	2045700	2273000	2557100	2841200
10 $\frac{3}{4}$	90.76	1829400	2195300	2439300	2744200	3049100
11	95.03	1960100	2352100	2613400	2940100	3266800
11 $\frac{1}{4}$	99.40	2096800	2516100	2795700	3145200	3494800
11 $\frac{1}{2}$	103.87	2239700	2687600	2986300	3359500	3732800
12	113.10	2544700	3053600	3392900	3817000	4241200

SPECIFIC GRAVITIES AND WEIGHTS

Water at 4° C. and Normal Atmospheric Pressure

Substance	Specific Gravity	Weight, lbs. per Cu. Ft.	Substance	Specific Gravity	Weight, lbs. per Cu. Ft.
Metals, Alloys, Ores			Timber, U. S. Seasoned		
Aluminum, cast—hammered	2.55-2.75	165	Ash, white—red	0.60-0.65	40
Aluminum, bronze	7.7	481	Cedar, white—red	0.32-0.38	22
Brass, cast—rolled	8.4-8.7	534	Chestnut	0.66	41
Bronze, 7.9 to 14% Sn.	7.4-8.9	509	Cypress	0.48	30
Copper, cast—rolled	8.8-9.0	556	Fir, Douglas spruce	0.51	32
Copper ore, pyrites	4.1-4.3	262	Fir, eastern	0.40	25
Gold, cast—hammered	19.25-19.3	1205	Elm, white	0.72	45
Iron, cast, pig	7.2	450	Hemlock	0.42-0.52	29
Iron, wrought	7.6-7.9	485	Hickory	0.74-0.84	49
Iron, steel	7.8-7.9	490	Locust	0.73	46
Iron, spiegel-eisen	7.5	468	Maple—hard	0.68	43
Iron, ferro-silicon	6.7-7.3	437	Maple—white	0.53	33
Iron ore, hematite	5.2	325	Oak, chestnut	0.86	54
Iron ore, hematite in bank		160-180	Oak, live	0.95	59
Iron ore, hematite loose		130-160	Oak, red, black	0.65	41
Iron ore, limonite	3.6-4.0	237	Oak, white	0.74	46
Iron ore, magnetite	4.9-5.2	315	Pine, Oregon	0.51	32
Iron slag	2.5-3.0	172	Pine, red	0.48	30
Lead	11.37	710	Pine, white	0.41	26
Lead ore, galena	7.3-7.6	465	Pine, yellow, long-leaf	0.70	44
Manganese	7.2-8.0	475	Pine, yellow, short-leaf	0.61	38
Manganese ore, pyrolusite	3.7-4.6	259	Poplar	0.48	30
Mercury	13.6	849	Redwood, California	0.42	26
Nickel	8.9-9.2	565	Spruce, white, black	0.40-0.46	27
Nickel, monel metal	8.8-9.0	556	Walnut, black	0.61	38
Platinum, cast—hammered	21.1-21.5	1330	Walnut, white	0.41	26
Silver, cast—hammered	10.4-10.6	656	Moisture Contents:		
Tin, cast—hammered	7.2-7.5	459	Seasoned timber, 15 to 20%		
Tin ore, cassiterite	6.4-7.0	418	Green timber, up to 50%		
Zinc, cast rolled	6.9-7.2	440			
Zinc ore, blende	3.9-4.2	253			
Various Solids			Various Liquids		
Cereals, oats, bulk		32	Alcohol, 100%	0.79	49
Cereals, barley, bulk		39	Acids, muriatic, 40%	1.20	75
Cereals, corn, rye, bulk		48	Acids, nitric, 91%	1.50	94
Cereals, wheat, bulk		48	Acids, sulphuric, 87%	1.80	112
Hay and straw, bales		20	Lye, soda, 66%	1.70	106
Cotton, flax, hemp	1.47-1.50	93	Oils, vegetable	0.91-0.94	58
Fats	0.90-0.97	58	Oils, mineral, lubricants	0.90-0.93	57
Flour, loose	0.40-0.50	28	Water, 4° C., max. density	1.0	62.428
Flour, pressed	0.70-0.80	47	Water, 100° C.	0.9584	59.830
Glass, common	2.40-2.60	156	Water, ice	0.88-0.92	56
Glass, plate or crown	2.45-2.72	161	Water, snow, fresh fallen	.125	8
Glass, crystal	2.90-3.00	184	Water, sea water	1.02-1.03	64
Leather	0.86-1.02	59			
Paper	0.70-1.15	58			
Potatoes, piled		42	Gases, Air = 1		
Rubber, caoutchouc	0.92-0.96	59	Air, 0° C., 760 mm.	1.0	.08071
Rubber goods	1.0-2.0	94	Ammonia	0.5920	.0478
Salt, granulated, piled		48	Carbon dioxide	1.5291	.1234
Salt peter		67	Carbon monoxide	0.9673	.0781
Starch	1.53	96	Gas, illuminating	0.35-0.45	.028-.036
Sulphur	1.93-2.07	125	Gas, natural	0.47-0.48	.038-.039
Wool	1.32	82	Hydrogen	0.0693	.00559
			Nitrogen	0.9714	.0784
			Oxygen	1.1056	.0892

SPECIFIC GRAVITIES AND WEIGHTS

Water at 4° C. and Normal Atmospheric Pressure

Substance	Specific Gravity	Weight, lbs. per Cu. Ft.	Substance	Specific Gravity	Weight, lbs. per Cu. Ft.
Ashlar Masonry			Minerals		
Granite, syenite, gneiss	2.3-3.0	165	Asbestos	2.1-2.8	153
Limestone, marble	2.3-2.8	160	Barytes	4.50	281
Sandstone, bluestone	2.1-2.4	140	Basalt	2.7-3.2	184
Mortar Rubble Masonry			Bauxite	2.55	159
Granite, syenite, gneiss	2.2-2.8	155	Borax	1.7-1.8	109
Limestone, marble	2.2-2.6	150	Chalk	1.8-2.6	137
Sandstone, bluestone	2.0-2.2	130	Clay, marl	1.8-2.6	137
Dry Rubble Masonry			Dolomite	2.9	181
Granite, syenite, gneiss	1.9-2.3	130	Feldspar, orthoclase	2.5-2.6	159
Limestone, marble	1.9-2.1	125	Gneiss, serpentine	2.4-2.7	159
Sandstone, bluestone	1.8-1.9	110	Granite, syenite	2.5-3.1	175
Brick Masonry			Greenstone, trap	2.8-3.2	187
Pressed brick	2.2-2.3	140	Gypsum, alabaster	2.3-2.8	159
Common brick	1.8-2.0	120	Hornblende	3.0	187
Soft brick	1.5-1.7	100	Limestone, marble	2.5-2.8	165
Concrete Masonry			Magnesite	3.0	187
Cement, stone, sand	2.2-2.4	144	Phosphate rock, apatite	3.2	200
Cement, slag, etc	1.9-2.3	130	Porphyry	2.6-2.9	172
Cement, cinder, etc	1.5-1.7	100	Pumice, natural	0.37-0.90	40
Various Building Mat'l			Quartz, flint	2.5-2.8	165
Ashes, cinders		40-45	Sandstone, bluestone	2.2-2.5	147
Cement, portland, loose		90	Shale, slate	2.7-2.9	175
Cement, portland, set	2.7-3.2	183	Soapstone, talc	2.6-2.8	169
Lime, gypsum, loose		53-64	Stone, Quarried, Piled		
Mortar, set	1.4-1.9	103	Basalt, granite, gneiss		96
Slags, bank slag		67-72	Limestone, marble, quartz		95
Slags, bank screenings		98-117	Sandstone		82
Slags, machine slag		96	Shale		92
Slags, slag and sand		49-55	Greenstone, hornblende		107
Earth, etc., Excavated			Bituminous Substances		
Clay, dry		63	Asphaltum	1.1-1.5	81
Clay, damp, plastic		110	Coal, anthracite	1.4-1.7	97
Clay and gravel, dry		100	Coal, bituminous	1.2-1.5	84
Earth, dry, loose		76	Coal, lignite	1.1-1.4	78
Earth, dry, packed		95	Coal, peat, turf, dry	0.65-0.85	47
Earth, moist, loose		78	Coal, charcoal, pine	0.28-0.44	23
Earth, moist, packed		96	Coal, charcoal, oak	0.47-0.57	33
Earth, mud, flowing		108	Coal, coke	1.0-1.4	75
Earth, mud, packed		115	Graphite	1.9-2.3	131
Riprap, limestone		80-85	Paraffine	0.87-0.91	56
Riprap, sandstone		90	Petroleum	0.87	54
Riprap, shale		105	Petroleum, refined	0.79-0.82	50
Sand, gravel, dry, loose		90-105	Petroleum, benzine	0.73-0.75	46
Sand, gravel, dry, packed		100-120	Petroleum, gasoline	0.66-0.69	42
Sand, gravel, dry, wet		118-120	Pitch	1.07-1.15	69
Excavations in Water			Tar, bituminous	1.20	75
Sand or gravel		60	Coal and Coke, Piled		
Sand or gravel and clay		65	Coal, anthracite		47-58
Clay		80	Coal, bituminous, lignite		40-54
River mud		90	Coal, peat, turf		20-26
Soil		70	Coal, charcoal		10-14
Stone riprap		65	Coal, coke		23-32

APPROXIMATE WEIGHTS OF ROOFING MATERIAL

Roofing Material	Weight per Sq. Foot, Pounds
Copper roofing, sheets	1½
Corrugated galvanized iron, No. 20 B.W.G.	2¼
Corrugated galvanized iron No. 26 B.W.G.	1¼
Felt, 2 layers	½
Felt and asphalt or coal-tar	2
Glass, ⅛ inch thick	1¾
Lath and plaster ceiling	6 to 8
Lead, ⅛ inch thick	7½
Mackite, 1 inch thick with plaster	10
Sheathing, hemlock, 1 inch thick	2
Sheathing, white pine, spruce, 1 inch thick	2¼ to 2½
Sheathing, yellow pine, 1 inch thick	3½
Shingles, 6 × 18 inches, 6 inches to weather	2
Skylight, glass ⅜ to ½ inch, including frame	4 to 10
Slag roof, 4-ply, with cement and sand	4
Slate, ⅛ inch thick, 3 inch double lap	4½
Slate, ⅜ inch thick, 3 inch double lap	6¾
Tar and Gravel Roofing, without sheathing	8 to 10
Terneplate, 1C	⅝
Terneplate, 1X	½
Tiles, flat	15 to 20
Tiles, corrugated	8 to 10
Tiles, on concrete slabs	30 to 35
Tin, without sheathing	1 to 1½
Zinc, No. 20 B.W.G.	1½

WEIGHTS OF WASHERS IN POUNDS

Upper Weight—washers with $1\frac{3}{16}$ holes

Lower “ “ “ $1\frac{5}{16}$ “



Thickness	Diameter						
	2	$2\frac{1}{4}$	$2\frac{1}{2}$	$2\frac{3}{4}$	3	$3\frac{1}{4}$	$3\frac{1}{2}$
$\frac{1}{4}$.186	.245	.311	.384	.464	.551	.645
	.173	.233	.299	.372	.452	.538	.632
$\frac{5}{16}$.232	.306	.389	.480	.580	.689	.806
	.216	.291	.374	.465	.565	.672	.790
$\frac{3}{8}$.279	.367	.467	.576	.696	.827	.967
	.259	.349	.449	.558	.678	.807	.948
$\frac{7}{16}$.325	.428	.545	.672	.812	.965	1.128
	.302	.407	.524	.651	.791	.942	1.106
$\frac{1}{2}$.372	.490	.622	.768	.928	1.102	1.290
	.346	.465	.598	.744	.903	1.076	1.264
$\frac{9}{16}$.418	.551	.700	.864	1.044	1.240	1.451
	.389	.523	.673	.837	1.016	1.211	1.423
$\frac{5}{8}$.465	.612	.778	.960	1.160	1.378	1.612
	.432	.581	.748	.930	1.129	1.346	1.581
$1\frac{1}{16}$.511	.673	.856	1.056	1.276	1.516	1.773
	.475	.639	.823	1.023	1.242	1.480	1.739
$\frac{3}{4}$.558	.735	.933	1.152	1.392	1.653	1.935
	.519	.697	.897	1.116	1.355	1.615	1.897
$1\frac{3}{16}$.604	.796	1.011	1.248	1.508	1.791	2.096
	.562	.755	.972	1.209	1.467	1.750	2.055
$\frac{7}{8}$.651	.857	1.089	1.344	1.624	1.929	2.257
	.605	.813	1.046	1.302	1.580	1.884	2.214
$1\frac{5}{16}$.697	.918	1.167	1.440	1.740	2.067	2.418
	.648	.871	1.121	1.395	1.693	2.019	2.372
1	.744	.980	1.244	1.536	1.856	2.204	2.580
	.692	.930	1.195	1.488	1.806	2.154	2.530

WEIGHTS OF WASHERS WITH LARGER HOLES

For each $\frac{1}{16}$ thickness of washer deduct the following amounts from the weights given above for washers with $1\frac{3}{16}$ holes.

For washers with $1\frac{1}{16}$ holes, deduct .0065 for each $\frac{1}{16}$ thickness.
 “ “ “ $1\frac{3}{16}$ “ “ .0104 “ “ $\frac{1}{16}$ “
 “ “ “ $1\frac{5}{16}$ “ “ .0148 “ “ $\frac{1}{16}$ “
 “ “ “ $1\frac{7}{16}$ “ “ .0247 “ “ $\frac{1}{16}$ “

TABLE OF WEIGHTS AND DIMENSIONS FOR BLACK AND GALVANIZED STANDARD PIPE

Size, Inches	External Diameter, Inches	Internal Diameter, Inches	Thickness, Inches	Weight per Foot, Pounds	Threads per Inch	COUPLINGS		
						Diameter, Inches	Length, Inches	Weight, Pounds
$\frac{1}{8}$.41	.27	.07	.24	27	.56	$\frac{7}{8}$.03
$\frac{1}{4}$.54	.36	.09	.42	18	.69	1	.04
$\frac{3}{8}$.68	.49	.09	.57	18	.85	$1\frac{1}{8}$.07
$\frac{1}{2}$.84	.62	.11	.85	14	1.02	$1\frac{3}{8}$.12
$\frac{3}{4}$	1.05	.82	.11	1.13	14	1.28	$1\frac{5}{8}$.21
1	1.32	1.05	.13	1.68	$11\frac{1}{2}$	1.58	$1\frac{7}{8}$.34
$1\frac{1}{4}$	1.66	1.38	.14	2.27	$11\frac{1}{2}$	1.95	$2\frac{1}{8}$.54
$1\frac{1}{2}$	1.90	1.61	.15	2.72	$11\frac{1}{2}$	2.22	$2\frac{3}{8}$.74
2	2.38	2.07	.15	3.65	$11\frac{1}{2}$	2.76	$2\frac{5}{8}$	1.21
$2\frac{1}{2}$	2.88	2.47	.20	5.79	8	3.28	$2\frac{7}{8}$	1.72
3	3.50	3.07	.22	7.58	8	3.95	$3\frac{1}{8}$	2.50
$3\frac{1}{2}$	4.00	3.55	.23	9.11	8	4.59	$3\frac{5}{8}$	4.24
4	4.50	4.03	.24	10.79	8	5.09	$3\frac{5}{8}$	4.74
$4\frac{1}{2}$	5.00	4.51	.25	12.54	8	5.59	$3\frac{5}{8}$	5.24
5	5.56	5.05	.26	14.62	8	6.30	$4\frac{1}{8}$	8.09
6	6.63	6.07	.28	18.97	8	7.36	$4\frac{1}{8}$	9.55
7	7.63	7.02	.30	23.54	8	8.36	$4\frac{1}{8}$	10.93
8	8.63	8.07	.28	24.70	8	9.36	$4\frac{5}{8}$	13.91
8	8.63	7.98	.32	28.55	8	9.36	$4\frac{5}{8}$	13.91
9	9.63	8.94	.34	33.91	8	10.36	$5\frac{1}{8}$	17.24
10	10.75	10.19	.28	31.20	8	11.72	$6\frac{1}{8}$	29.88
10	10.75	10.14	.31	34.24	8	11.72	$6\frac{1}{8}$	29.88
10	10.75	10.02	.37	40.48	8	11.72	$6\frac{1}{8}$	29.88
11	11.75	11.00	.38	45.56	8	12.72	$6\frac{1}{8}$	32.55
12	12.75	12.09	.33	43.77	8	13.96	$6\frac{1}{8}$	43.10
12	12.75	12.00	.38	49.56	8	13.96	$6\frac{1}{8}$	43.10
13	14.00	13.25	.38	54.57	8	15.21	$6\frac{1}{8}$	47.15
14	15.00	14.25	.38	58.57	8	16.45	$6\frac{1}{8}$	59.49
15	16.00	15.25	.38	62.58	8	17.45	$6\frac{1}{8}$	63.29

TABLE OF WEIGHTS AND DIMENSIONS FOR BLACK AND GALVANIZED PIPE

EXTRA STRONG PIPE





DOUBLE EXTRA STRONG PIPE

Size, Inches	External Diameter, Inches	Internal Diameter, Inches	Thickness, Inches	Weight per Foot, Pounds	Size, Inches	External Diameter, Inches	Internal Diameter, Inches	Thickness, Inches	Weight per Foot, Pounds
$\frac{1}{8}$.41	.22	.10	.31	$\frac{1}{2}$.84	.25	.29	1.71
$\frac{1}{4}$.54	.30	.12	.54	$\frac{3}{4}$	1.05	.43	.31	2.44
$\frac{3}{8}$.68	.42	.13	.74	1	1.32	.60	.36	3.66
$\frac{1}{2}$.84	.55	.15	1.09	$1\frac{1}{4}$	1.66	.90	.38	5.21
$\frac{3}{4}$	1.05	.74	.15	1.47	$1\frac{1}{2}$	1.90	1.10	.40	6.41
1	1.32	.96	.18	2.17	2	2.38	1.50	.44	9.03
$1\frac{1}{4}$	1.66	1.28	.19	3.00	$2\frac{1}{2}$	2.88	1.77	.55	13.70
$1\frac{1}{2}$	1.90	1.50	.20	3.63	3	3.50	2.30	.60	18.58
2	2.38	1.94	.22	5.02	$3\frac{1}{2}$	4.00	2.73	.64	22.85
$2\frac{1}{2}$	2.88	2.32	.28	7.66	4	4.50	3.15	.67	27.54
3	3.50	2.90	.30	10.25	$4\frac{1}{2}$	5.00	3.58	.71	32.53
$3\frac{1}{2}$	4.00	3.36	.32	12.51	5	5.56	4.06	.75	38.55
4	4.50	3.83	.34	14.98	6	6.63	4.90	.86	53.16
$4\frac{1}{2}$	5.00	4.29	.36	17.61	7	7.63	5.88	.88	63.08
5	5.56	4.81	.38	20.78	8	8.63	6.88	.88	72.42
6	6.63	5.76	.43	28.57					
7	7.63	6.63	.50	38.05					
8	8.63	7.63	.50	43.39					
9	9.63	8.63	.50	48.73					
10	10.75	9.75	.50	54.74					
11	11.75	10.75	.50	60.08					
12	12.75	11.75	.50	65.42					
13	14.00	13.00	.50	72.09					
14	15.00	14.00	.50	77.43					
15	16.00	15.00	.50	82.77					

SQUARE AND ROUND BARS

WEIGHTS, AREAS AND CIRCUMFERENCES





 $\frac{1}{16}$ TO 2

Thickness or Diameter in Inches	WEIGHT IN POUNDS				AREA IN SQ. INCHES		Circum- ference
	SQUARE 		ROUND 		Square 	Round 	
	One Inch Long	One Foot Long	One Inch Long	One Foot Long			
$\frac{1}{16}$.001	.013	.001	.010	.0039	.0031	.1964
$\frac{1}{8}$.004	.053	.004	.042	.0156	.0123	.3927
$\frac{3}{16}$.010	.120	.008	.094	.0352	.0276	.5891
$\frac{1}{4}$.018	.212	.014	.167	.0625	.0491	.7854
$\frac{5}{16}$.028	.332	.022	.261	.0977	.0767	.9818
$\frac{3}{8}$.040	.478	.031	.376	.1406	.1104	1.1781
$\frac{7}{16}$.054	.651	.043	.511	.1914	.1503	1.3745
$\frac{1}{2}$.071	.850	.056	.668	.2500	.1963	1.5708
$\frac{9}{16}$.090	1.076	.070	.845	.3164	.2485	1.7672
$\frac{5}{8}$.111	1.328	.087	1.043	.3906	.3068	1.9635
$\frac{11}{16}$.134	1.607	.105	1.262	.4727	.3712	2.1599
$\frac{3}{4}$.159	1.913	.125	1.502	.5625	.4418	2.3562
$\frac{13}{16}$.187	2.245	.147	1.763	.6602	.5185	2.5526
$\frac{7}{8}$.217	2.603	.170	2.044	.7656	.6013	2.7489
$\frac{15}{16}$.249	2.988	.196	2.347	.8789	.6903	2.9453
1	.28	3.400	.22	2.670	1.0000	.7854	3.1416
$\frac{1}{16}$.32	3.838	.25	3.015	1.1289	.8866	3.3380
$\frac{1}{8}$.36	4.303	.28	3.380	1.2656	.9940	3.5343
$\frac{3}{16}$.40	4.795	.31	3.766	1.4102	1.1075	3.7306
$\frac{1}{4}$.44	5.313	.35	4.172	1.5625	1.2272	3.9270
$\frac{5}{16}$.49	5.857	.38	4.600	1.7227	1.3530	4.1234
$\frac{3}{8}$.54	6.428	.42	5.049	1.8906	1.4849	4.3197
$\frac{7}{16}$.58	7.026	.46	5.518	2.0664	1.6230	4.5161
$\frac{1}{2}$.64	7.650	.50	6.008	2.2500	1.7671	4.7124
$\frac{9}{16}$.69	8.301	.54	6.519	2.4414	1.9175	4.9088
$\frac{5}{8}$.75	8.978	.59	7.051	2.6406	2.0739	5.1051
$\frac{11}{16}$.81	9.682	.63	7.604	2.8477	2.2365	5.3015
$\frac{3}{4}$.87	10.41	.68	8.178	3.0625	2.4053	5.4978
$\frac{13}{16}$.94	11.17	.73	8.773	3.2852	2.5802	5.6942
$\frac{7}{8}$	1.00	11.95	.78	9.388	3.5156	2.7612	5.8905
$\frac{15}{16}$	1.06	12.76	.84	10.02	3.7539	2.9483	6.0869
2	1.13	13.60	.89	10.68	4.0000	3.1416	6.2832

SQUARE AND ROUND BARS

WEIGHTS, AREAS AND CIRCUMFERENCES





2 1/16 TO 4

Thickness or Diameter in Inches	WEIGHT IN POUNDS				AREA IN SQ. INCHES		○ Circum- ference
	SQUARE 		ROUND 		 Square	 Round	
	One Inch Long	One Foot Long	One Inch Long	One Foot Long			
2 1/16	1.21	14.46	.95	11.36	4.2539	3.3410	6.4796
1 1/8	1.28	15.35	1.01	12.06	4.5156	3.5466	6.6759
3/8	1.36	16.27	1.07	12.78	4.7852	3.7583	6.8723
1/4	1.43	17.21	1.13	13.52	5.0625	3.9761	7.0686
5/16	1.52	18.18	1.19	14.28	5.3477	4.2000	7.2650
3/8	1.60	19.18	1.26	15.06	5.6406	4.4301	7.4613
7/16	1.68	20.20	1.32	15.87	5.9414	4.6664	7.6577
1/2	1.77	21.25	1.39	16.69	6.2500	4.9087	7.8540
9/16	1.86	22.33	1.46	17.53	6.5664	5.1573	8.0504
5/8	1.95	23.43	1.54	18.40	6.8906	5.4119	8.2467
11/16	2.05	24.56	1.61	19.29	7.2227	5.6727	8.4431
3/4	2.14	25.71	1.69	20.19	7.5625	5.9396	8.6394
13/16	2.24	26.90	1.76	21.12	7.9102	6.2126	8.8358
7/8	2.34	28.10	1.84	22.07	8.2656	6.4918	9.0321
15/16	2.44	29.34	1.92	23.04	8.6289	6.7771	9.2285
3	2.55	30.60	2.01	24.03	9.0000	7.0686	9.4248
1/16	2.66	31.89	2.09	25.05	9.3789	7.3662	9.6212
1/8	2.77	33.20	2.18	26.08	9.7656	7.6699	9.8175
3/16	2.88	34.55	2.26	27.13	10.160	7.9798	10.014
1/4	2.99	35.92	2.35	28.21	10.563	8.2958	10.210
5/16	3.11	37.31	2.44	29.30	10.973	8.6179	10.407
3/8	3.23	38.73	2.53	30.42	11.391	8.9462	10.603
7/16	3.35	40.18	2.63	31.55	11.816	9.2806	10.799
1/2	3.47	41.65	2.73	32.71	12.250	9.6211	10.996
9/16	3.60	43.15	2.82	33.89	12.691	9.9678	11.192
5/8	3.72	44.68	2.92	35.09	13.141	10.321	11.388
11/16	3.85	46.23	3.03	36.31	13.598	10.680	11.585
3/4	3.98	47.82	3.13	37.55	14.063	11.045	11.781
13/16	4.12	49.42	3.23	38.81	14.535	11.416	11.977
7/8	4.25	51.05	3.34	40.10	15.016	11.793	12.174
15/16	4.39	52.71	3.45	41.40	15.504	12.177	12.370
4	4.53	54.40	3.57	42.73	16.000	12.566	12.566

SQUARE AND ROUND BARS

WEIGHTS, AREAS AND CIRCUMFERENCES





4¹/₁₆ TO 6

Thickness or Diameter in Inches	WEIGHT IN POUNDS				AREA IN SQ. INCHES		○ Circum- ference
	SQUARE 		ROUND 		 Square	 Round	
	One Inch Long	One Foot Long	One Inch Long	One Foot Long			
4 ¹ / ₁₆	4.68	56.11	3.67	44.07	16.504	12.962	12.763
¹ / ₈	4.82	57.85	3.79	45.44	17.016	13.364	12.959
³ / ₁₆	4.97	59.62	3.90	46.83	17.535	13.772	13.155
¹ / ₄	5.12	61.41	4.02	48.24	18.063	14.186	13.352
⁵ / ₁₆	5.27	63.23	4.14	49.66	18.598	14.607	13.548
³ / ₈	5.42	65.08	4.26	51.11	19.141	15.033	13.745
⁷ / ₁₆	5.58	66.95	4.38	52.58	19.691	15.466	13.941
¹ / ₂	5.74	68.85	4.51	54.07	20.250	15.904	14.137
⁹ / ₁₆	5.90	70.78	4.63	55.59	20.816	16.349	14.334
⁵ / ₈	6.06	72.73	4.76	57.12	21.391	16.800	14.530
¹¹ / ₁₆	6.23	74.71	4.89	58.67	21.973	17.257	14.726
³ / ₄	6.39	76.71	5.02	60.25	22.563	17.721	14.923
¹³ / ₁₆	6.56	78.74	5.15	61.85	23.160	18.190	15.119
⁷ / ₈	6.73	80.80	5.29	63.46	23.766	18.665	15.315
¹⁵ / ₁₆	6.91	82.89	5.42	65.10	24.379	19.147	15.512
5	7.08	85.00	5.56	66.76	25.000	19.635	15.708
¹ / ₁₆	7.26	87.14	5.70	68.44	25.629	20.129	15.904
¹ / ₈	7.44	89.30	5.84	70.14	26.266	20.629	16.101
³ / ₁₆	7.62	91.49	5.99	71.86	26.910	21.135	16.297
¹ / ₄	7.81	93.71	6.13	73.60	27.563	21.648	16.493
⁵ / ₁₆	8.00	95.96	6.28	75.37	28.223	22.166	16.690
³ / ₈	8.19	98.23	6.43	77.15	28.891	22.691	16.886
⁷ / ₁₆	8.38	100.5	6.58	78.95	29.566	23.221	17.082
¹ / ₂	8.57	102.9	6.73	80.78	30.250	23.758	17.279
⁹ / ₁₆	8.77	105.2	6.88	82.62	30.941	24.301	17.475
⁵ / ₈	8.96	107.6	7.04	84.49	31.641	24.851	17.672
¹¹ / ₁₆	9.16	110.0	7.20	86.38	32.348	25.406	17.868
³ / ₄	9.37	112.4	7.36	88.29	33.063	25.967	18.064
¹³ / ₁₆	9.57	114.9	7.52	90.22	33.785	26.535	18.261
⁷ / ₈	9.78	117.4	7.68	92.17	34.516	27.109	18.457
¹⁵ / ₁₆	9.99	119.9	7.84	94.14	35.254	27.688	18.653
6	10.20	122.4	8.01	96.13	36.000	28.274	18.850

SQUARE AND ROUND BARS

6¹/₁₆ TO 8

WEIGHTS, AREAS AND CIRCUMFERENCES

Thickness or Diameter in Inches	WEIGHT IN POUNDS				AREA IN SQ. INCHES		Circum- ference
	SQUARE 		ROUND 		 Square	 Round	
	One Inch Long	One Foot Long	One Inch Long	One Foot Long			
6 ¹ / ₁₆	10.41	125.0	8.18	98.15	36.754	28.867	19.046
1 ¹ / ₈	10.63	127.6	8.35	100.2	37.516	29.465	19.242
3 ¹ / ₁₆	10.85	130.2	8.52	102.2	38.285	30.069	19.439
1 ¹ / ₄	11.07	132.8	8.69	104.3	39.063	30.680	19.635
5 ¹ / ₁₆	11.29	135.5	8.87	106.4	39.848	31.296	19.831
3 ¹ / ₈	11.51	138.2	9.04	108.5	40.641	31.919	20.028
7 ¹ / ₁₆	11.74	140.9	9.22	110.7	41.441	32.548	20.224
1 ¹ / ₂	11.97	143.7	9.40	112.8	42.250	33.183	20.420
9 ¹ / ₁₆	12.20	146.5	9.58	115.0	43.066	33.824	20.617
5 ¹ / ₈	12.43	149.2	9.77	117.2	43.891	34.472	20.813
11 ¹ / ₁₆	12.67	152.1	9.95	119.4	44.723	35.125	21.009
3 ¹ / ₄	12.91	154.9	10.14	121.7	45.563	35.785	21.206
13 ¹ / ₁₆	13.15	157.8	10.33	123.9	46.410	36.451	21.402
7 ¹ / ₈	13.39	160.7	10.52	126.2	47.266	37.122	21.599
15 ¹ / ₁₆	13.64	163.6	10.71	128.5	48.129	37.800	21.795
7	13.88	166.6	10.90	130.8	49.000	38.485	21.991
1 ¹ / ₁₆	14.13	169.6	11.10	133.2	49.879	39.175	22.188
1 ¹ / ₈	14.38	172.6	11.30	135.6	50.766	39.871	22.384
3 ¹ / ₁₆	14.64	175.6	11.50	138.0	51.660	40.574	22.580
1 ¹ / ₄	14.89	178.7	11.70	140.4	52.563	41.283	22.777
5 ¹ / ₁₆	15.15	181.8	11.90	142.8	53.473	41.997	22.973
3 ¹ / ₈	15.41	184.9	12.10	145.2	54.391	42.718	23.169
7 ¹ / ₁₆	15.67	188.1	12.31	147.7	55.316	43.446	23.366
1 ¹ / ₂	15.94	191.3	12.52	150.2	56.250	44.179	23.562
9 ¹ / ₁₆	16.20	194.5	12.73	152.7	57.191	44.918	23.758
5 ¹ / ₈	16.47	197.7	12.94	155.3	58.141	45.664	23.955
11 ¹ / ₁₆	16.74	200.9	13.15	157.8	59.098	46.415	24.151
3 ¹ / ₄	17.02	204.2	13.36	160.4	60.063	47.173	24.347
13 ¹ / ₁₆	17.29	207.5	13.58	163.0	61.035	47.937	24.544
7 ¹ / ₈	17.57	210.9	13.80	165.6	62.016	48.707	24.740
15 ¹ / ₁₆	17.85	214.2	14.02	168.2	63.004	49.483	24.936
8	18.11	217.6	14.24	170.9	64.000	50.266	25.133

WEIGHTS OF FLAT ROLLED STEEL

POUNDS PER LINEAR FOOT

Width, Inches	THICKNESS, INCHES												1			
	1/16	1/8	3/16	1/4	5/16	3/8	7/16	1/2	5/8	11/16	3/4	13/16		7/8	15/16	
1/4	.053	.106	.159	.213	.27	.32	.37	.43	.48	.53	.58	.64	.69	.74	.80	.85
1/2	.106	.213	.319	.425	.53	.64	.74	.85	.96	1.06	1.17	1.28	1.38	1.49	1.59	1.70
3/4	.159	.319	.478	.638	.80	.96	1.12	1.28	1.43	1.59	1.75	1.91	2.07	2.23	2.39	2.55
1	.213	.425	.638	.850	1.06	1.28	1.49	1.70	1.91	2.13	2.34	2.55	2.76	2.98	3.19	3.40
1 1/4	.266	.531	.797	1.063	1.33	1.59	1.86	2.13	2.39	2.66	2.92	3.19	3.45	3.72	3.98	4.25
1 1/2	.319	.638	.956	1.275	1.59	1.91	2.23	2.55	2.87	3.19	3.51	3.83	4.14	4.46	4.78	5.10
1 3/4	.372	.744	1.116	1.488	1.86	2.23	2.60	2.98	3.35	3.72	4.09	4.46	4.83	5.21	5.58	5.95
2	.425	.850	1.275	1.700	2.13	2.55	2.98	3.40	3.83	4.25	4.68	5.10	5.53	5.95	6.38	6.80
2 1/4	.478	.956	1.434	1.913	2.39	2.87	3.35	3.83	4.30	4.78	5.26	5.74	6.22	6.69	7.17	7.65
2 1/2	.531	1.063	1.594	2.125	2.66	3.19	3.72	4.25	4.78	5.31	5.84	6.38	6.91	7.44	7.97	8.50
2 3/4	.584	1.169	1.753	2.338	2.92	3.51	4.09	4.68	5.26	5.84	6.43	7.01	7.60	8.18	8.77	9.35
3	.638	1.275	1.913	2.550	3.19	3.83	4.46	5.10	5.74	6.38	7.01	7.65	8.29	8.93	9.56	10.20
3 1/4	.691	1.381	2.072	2.763	3.45	4.14	4.83	5.53	6.22	6.91	7.60	8.29	8.98	9.67	10.36	11.05
3 1/2	.744	1.488	2.231	2.975	3.72	4.46	5.21	5.95	6.69	7.44	8.18	8.93	9.67	10.41	11.16	11.90
3 3/4	.797	1.594	2.391	3.188	3.98	4.78	5.58	6.38	7.17	7.97	8.77	9.56	10.36	11.16	11.95	12.75
4	.850	1.700	2.550	3.400	4.25	5.10	5.95	6.80	7.65	8.50	9.35	10.20	11.05	11.90	12.75	13.60
4 1/4	.903	1.806	2.709	3.613	4.52	5.42	6.32	7.23	8.13	9.03	9.93	10.84	11.74	12.64	13.55	14.45
4 1/2	.956	1.913	2.869	3.825	4.78	5.74	6.69	7.65	8.61	9.56	10.52	11.48	12.43	13.39	14.34	15.30
4 3/4	1.009	2.019	3.028	4.038	5.05	6.06	7.07	8.08	9.08	10.09	11.10	12.11	13.12	14.13	15.14	16.15
5	1.063	2.125	3.188	4.250	5.31	6.38	7.44	8.50	9.56	10.63	11.69	12.75	13.81	14.88	15.94	17.00
5 1/4	1.116	2.231	3.347	4.463	5.58	6.69	7.81	8.93	10.04	11.16	12.27	13.39	14.50	15.62	16.73	17.85
5 1/2	1.169	2.338	3.506	4.675	5.84	7.01	8.18	9.35	10.52	11.69	12.86	14.03	15.19	16.36	17.53	18.70
5 3/4	1.222	2.444	3.666	4.888	6.11	7.33	8.55	9.78	11.00	12.22	13.44	14.66	15.88	17.11	18.33	19.55
6	1.275	2.550	3.825	5.100	6.38	7.65	8.93	10.20	11.48	12.75	14.03	15.30	16.58	17.85	19.13	20.40
6 1/4	1.328	2.656	3.984	5.313	6.64	7.97	9.30	10.63	11.95	13.28	14.61	15.94	17.27	18.59	19.92	21.25
6 1/2	1.381	2.763	4.144	5.525	6.91	8.29	9.67	11.05	12.43	13.81	15.19	16.58	17.96	19.34	20.72	22.10
	1/16	1/8	3/16	1/4	5/16	3/8	7/16	1/2	5/8	11/16	3/4	13/16	7/8	15/16		1

WEIGHTS OF FLAT ROLLED STEEL
POUNDS PER LINEAR FOOT

THICKNESS, INCHES

Width, Inches	1/16	1/8	3/16	1/4	5/16	3/8	7/16	1/2	5/8	11/16	3/4	13/16	7/8	15/16	1
6 3/4	1.434	2.869	4.303	5.738	7.17	8.61	10.04	11.48	12.91	14.34	15.78	17.21	18.65	20.08	21.52
7	1.488	2.975	4.463	5.950	7.44	8.93	10.41	11.90	13.39	14.88	16.36	17.85	19.34	20.83	22.31
7 1/4	1.541	3.081	4.622	6.163	7.70	9.24	10.78	12.33	13.87	15.41	16.95	18.49	20.03	21.57	23.11
7 1/2	1.594	3.188	4.781	6.375	7.97	9.56	11.16	12.75	14.34	15.94	17.53	19.13	20.72	22.31	23.91
7 3/4	1.647	3.294	4.941	6.588	8.23	9.88	11.53	13.18	14.82	16.47	18.12	19.76	21.41	23.06	24.70
8	1.700	3.400	5.100	6.800	8.50	10.20	11.90	13.60	15.30	17.00	18.70	20.40	22.10	23.80	25.50
8 1/4	1.753	3.506	5.259	7.013	8.77	10.52	12.27	14.03	15.78	17.53	19.28	21.04	22.79	24.54	26.30
8 1/2	1.806	3.613	5.419	7.225	9.03	10.84	12.64	14.45	16.26	18.06	19.87	21.68	23.48	25.29	27.09
8 3/4	1.859	3.719	5.578	7.438	9.30	11.16	13.02	14.88	16.73	18.59	20.45	22.31	24.17	26.03	27.89
9	1.913	3.825	5.738	7.650	9.56	11.48	13.39	15.30	17.21	19.13	21.04	22.95	24.86	26.78	28.69
9 1/4	1.966	3.931	5.897	7.863	9.83	11.79	13.76	15.73	17.69	19.66	21.62	23.59	25.55	27.52	29.48
9 1/2	2.019	4.038	6.056	8.075	10.09	12.11	14.13	16.15	18.17	20.19	22.21	24.23	26.24	28.26	30.28
9 3/4	2.072	4.144	6.216	8.288	10.36	12.43	14.50	16.58	18.65	20.72	22.79	24.86	26.93	29.01	31.08
10	2.125	4.250	6.375	8.500	10.63	12.75	14.88	17.00	19.13	21.25	23.38	25.50	27.63	29.75	31.88
10 1/4	2.178	4.356	6.534	8.713	10.89	13.07	15.25	17.43	19.60	21.78	23.96	26.14	28.32	30.49	32.67
10 1/2	2.231	4.463	6.694	8.925	11.16	13.39	15.62	17.85	20.08	22.31	24.54	26.78	29.01	31.24	33.47
10 3/4	2.284	4.569	6.853	9.138	11.42	13.71	15.99	18.28	20.56	22.84	25.13	27.41	29.70	31.98	34.27
11	2.338	4.675	7.013	9.350	11.69	14.03	16.36	18.70	21.04	23.38	25.71	28.05	30.39	32.73	35.06
11 1/4	2.391	4.781	7.172	9.563	11.95	14.34	16.73	19.13	21.52	23.91	26.30	28.69	31.08	33.47	35.86
11 1/2	2.444	4.888	7.331	9.775	12.22	14.66	17.11	19.55	21.99	24.44	26.88	29.33	31.77	34.21	36.66
11 3/4	2.497	4.994	7.491	9.988	12.48	14.98	17.48	19.98	22.47	24.97	27.47	29.96	32.46	34.96	37.45
12	2.550	5.100	7.650	10.20	12.75	15.30	17.85	20.40	22.95	25.50	28.05	30.60	33.15	35.70	38.25
12 1/2	2.66	5.31	7.97	10.63	13.28	15.94	18.59	21.25	23.91	26.56	29.2	31.9	34.5	37.2	39.8
13	2.76	5.53	8.29	11.05	13.81	16.58	19.34	22.10	24.86	27.63	30.4	33.2	35.9	38.7	41.4
13 1/2	2.87	5.74	8.61	11.48	14.34	17.21	20.08	22.95	25.82	28.69	31.6	34.4	37.3	40.2	43.0
14	2.98	5.95	8.93	11.90	14.88	17.85	20.83	23.80	26.78	29.75	32.7	35.7	38.7	41.7	44.6

WEIGHTS OF FLAT ROLLED STEEL

POUNDS PER LINEAR FOOT

Width, Inches	THICKNESS, INCHES													1		
	1/16	1/8	3/16	1/4	5/16	3/8	1/2	5/8	3/4	7/8	15/16	1				
14 1/2	3.08	6.16	9.24	12.33	15.41	18.49	21.57	24.65	27.73	30.81	33.9	37.0	40.1	43.1	46.2	49.3
15	3.19	6.38	9.56	12.75	15.94	19.13	22.31	25.50	28.69	31.88	35.1	38.3	41.4	44.6	47.8	51.0
15 1/2	3.29	6.59	9.88	13.18	16.47	19.76	23.06	26.35	29.64	32.94	36.2	39.5	42.8	46.1	49.4	52.7
16	3.40	6.80	10.20	13.60	17.00	20.40	23.80	27.20	30.60	34.00	37.4	40.8	44.2	47.6	51.0	54.4
16 1/2	3.51	7.01	10.52	14.03	17.53	21.04	24.54	28.05	31.56	35.06	38.6	42.1	45.6	49.1	52.6	56.1
17	3.62	7.23	10.84	14.45	18.06	21.68	25.29	28.90	32.51	36.13	39.7	43.4	47.0	50.6	54.2	57.8
17 1/2	3.72	7.44	11.16	14.88	18.59	22.31	26.03	29.75	33.47	37.19	40.9	44.6	48.3	52.1	55.8	59.5
18	3.83	7.65	11.48	15.30	19.13	22.95	26.78	30.60	34.43	38.25	42.1	45.9	49.7	53.6	57.4	61.2
18 1/2	3.93	7.86	11.79	15.73	19.66	23.59	27.52	31.45	35.38	39.31	43.2	47.2	51.1	55.0	59.0	62.9
19	4.04	8.08	12.11	16.15	20.19	24.23	28.26	32.30	36.34	40.38	44.4	48.5	52.5	56.5	60.6	64.6
19 1/2	4.14	8.29	12.43	16.58	20.72	24.86	29.01	33.15	37.29	41.44	45.6	49.7	53.9	58.0	62.2	66.3
20	4.25	8.50	12.75	17.00	21.25	25.50	29.75	34.00	38.25	42.50	46.8	51.0	55.3	59.5	63.8	68.0
20 1/2	4.36	8.71	13.07	17.43	21.78	26.14	30.49	34.85	39.21	43.56	47.9	52.3	56.6	61.0	65.3	69.7
21	4.46	8.93	13.39	17.85	22.31	26.78	31.24	35.70	40.16	44.63	49.1	53.6	58.0	62.5	66.9	71.4
21 1/2	4.57	9.14	13.71	18.28	22.84	27.41	31.98	36.55	41.12	45.69	50.3	54.8	59.4	64.0	68.5	73.1
22	4.68	9.35	14.03	18.70	23.38	28.05	32.73	37.40	42.08	46.75	51.4	56.1	60.8	65.5	70.1	74.8
22 1/2	4.78	9.56	14.34	19.13	23.91	28.69	33.47	38.25	43.03	47.81	52.6	57.4	62.2	66.9	71.7	76.5
23	4.89	9.78	14.66	19.55	24.44	29.33	34.21	39.10	43.99	48.88	53.8	58.7	63.5	68.4	73.3	78.2
23 1/2	4.99	9.99	14.98	19.98	24.97	29.96	34.96	39.95	44.94	49.94	54.9	59.9	64.9	69.9	74.9	79.9
24	5.10	10.20	15.30	20.40	25.50	30.60	35.70	40.80	45.90	51.00	56.1	61.2	66.3	71.4	76.5	81.6
25	5.31	10.63	15.94	21.25	26.56	31.88	37.19	42.50	47.81	53.13	58.4	63.8	69.1	74.4	79.7	85.0
26	5.53	11.05	16.58	22.10	27.63	33.15	38.68	44.20	49.73	55.25	60.8	66.3	71.8	77.4	82.9	88.4
27	5.74	11.48	17.21	22.95	28.69	34.43	40.16	45.90	51.64	57.38	63.1	68.9	74.6	80.3	86.1	91.8
28	5.95	11.90	17.85	23.80	29.75	35.70	41.65	47.60	53.55	59.50	65.5	71.4	77.4	83.3	89.3	95.2
29	6.16	12.33	18.49	24.65	30.81	36.98	43.14	49.30	55.46	61.63	67.8	74.0	80.1	86.3	92.4	98.6
30	6.38	12.75	19.13	25.50	31.88	38.25	44.63	51.00	57.38	63.75	70.1	76.5	82.9	89.3	95.6	102.0
	1/16	1/8	3/16	1/4	5/16	3/8	1/2	5/8	3/4	7/8	15/16	1	15/16	1	15/16	1

WEIGHTS OF FLAT ROLLED STEEL

POUNDS PER LINEAR FOOT

THICKNESS, INCHES

Width, Inches	THICKNESS, INCHES															
	1/16	1/8	3/16	1/4	5/16	3/8	7/16	1/2	9/16	5/8	11/16	3/4	13/16	7/8	15/16	1
31	6.59	13.18	19.76	26.35	32.94	39.53	46.11	52.70	59.29	65.88	72.5	79.1	85.6	92.2	98.8	105.4
32	6.80	13.60	20.40	27.20	34.00	40.80	47.60	54.40	61.20	68.00	74.8	81.6	88.4	95.2	102.0	108.8
33	7.01	14.03	21.04	28.05	35.06	42.08	49.09	56.10	63.11	70.13	77.1	84.2	91.2	98.2	105.2	112.2
34	7.23	14.45	21.68	28.90	36.13	43.35	50.58	57.80	65.03	72.25	79.5	86.7	93.9	101.2	108.4	115.6
35	7.44	14.88	22.31	29.75	37.19	44.63	52.06	59.50	66.94	74.38	81.8	89.3	96.7	104.1	111.6	119.0
36	7.65	15.30	22.95	30.60	38.25	45.90	53.55	61.20	68.85	76.50	84.2	91.8	99.5	107.1	114.8	122.4
37	7.86	15.73	23.59	31.45	39.31	47.18	55.04	62.90	70.76	78.63	86.5	94.4	102.2	110.1	117.9	125.8
38	8.08	16.15	24.23	32.30	40.38	48.45	56.53	64.60	72.68	80.75	88.8	96.9	105.0	113.1	121.1	129.2
39	8.29	16.58	24.86	33.15	41.44	49.73	58.01	66.30	74.59	82.88	91.2	99.5	107.7	116.0	124.3	132.6
40	8.50	17.00	25.50	34.00	42.50	51.00	59.50	68.00	76.50	85.00	93.5	102.0	110.5	119.0	127.5	136.0
41	8.71	17.43	26.14	34.85	43.56	52.28	60.99	69.70	78.41	87.13	95.8	104.6	113.3	122.0	130.7	139.4
42	8.93	17.85	26.78	35.70	44.63	53.55	62.48	71.40	80.33	89.25	98.2	107.1	116.0	125.0	133.9	142.8
43	9.14	18.28	27.41	36.55	45.69	54.83	63.96	73.10	82.24	91.38	100.5	109.7	118.8	127.9	137.1	146.2
44	9.35	18.70	28.05	37.40	46.75	56.10	65.45	74.80	84.15	93.50	102.9	112.2	121.6	130.9	140.3	149.6
45	9.56	19.13	28.69	38.25	47.81	57.38	66.94	76.50	86.06	95.63	105.2	114.8	124.3	133.9	143.4	153.0
46	9.78	19.55	29.33	39.10	48.88	58.65	68.43	78.20	87.98	97.75	107.5	117.3	127.1	136.9	146.6	156.4
47	9.99	19.98	29.96	39.95	49.94	59.93	69.91	79.90	89.89	99.88	109.9	119.9	129.8	139.8	149.8	159.8
48	10.20	20.40	30.60	40.80	51.00	61.20	71.40	81.60	91.80	102.0	112.2	122.4	132.6	142.8	153.0	163.2
49	10.4	20.8	31.2	41.7	52.1	62.5	72.9	83.3	93.7	104.1	114.5	125.0	135.4	145.8	156.2	166.6
50	10.6	21.3	31.9	42.5	53.1	63.8	74.4	85.0	95.6	106.3	116.9	127.5	138.1	148.8	159.4	170.0
51	10.8	21.7	32.5	43.4	54.2	65.0	75.9	86.7	97.5	108.4	119.2	130.1	140.9	151.7	162.6	173.4
52	11.1	22.1	33.2	44.2	55.3	66.3	77.4	88.4	99.5	110.5	121.6	132.6	143.7	154.7	165.8	176.8
53	11.3	22.5	33.8	45.1	56.3	67.6	78.8	90.1	101.4	112.6	123.9	135.2	146.4	157.7	168.9	180.2
54	11.5	23.0	34.4	45.9	57.4	68.9	80.3	91.8	103.3	114.8	126.2	137.7	149.2	160.7	172.1	183.6
55	11.7	23.4	35.1	46.8	58.4	70.1	81.8	93.5	105.2	116.9	128.6	140.3	151.9	163.6	175.3	187.0
56	11.9	23.8	35.7	47.6	59.5	71.4	83.3	95.2	107.1	119.0	130.9	142.8	154.7	166.6	178.5	190.4

WEIGHTS OF FLAT ROLLED STEEL

POUNDS PER LINEAR FOOT

Width, Inches	THICKNESS, INCHES													1		
	1/16	1/8	3/16	1/4	5/16	3/8	7/16	1/2	9/16	5/8	11/16	3/4	13/16		7/8	15/16
57	12.1	24.2	36.3	48.5	60.6	72.7	84.8	96.9	109.0	121.1	133.2	145.4	157.5	169.6	181.7	193.8
58	12.3	24.7	37.0	49.3	61.6	74.0	86.3	98.6	110.9	123.3	135.6	147.9	160.2	172.6	184.9	197.2
59	12.5	25.1	37.6	50.2	62.7	75.2	87.8	100.3	112.8	125.4	137.9	150.5	163.0	175.5	188.1	200.6
60	12.8	25.5	38.3	51.0	63.8	76.5	89.3	102.0	114.8	127.5	140.3	153.0	165.8	178.5	191.3	204.0
61	13.0	25.9	38.9	51.9	64.8	77.8	90.7	103.7	116.7	129.6	142.6	155.6	168.5	181.5	194.4	207.4
62	13.2	26.4	39.5	52.7	65.9	79.1	92.2	105.4	118.6	131.8	144.9	158.1	171.3	184.5	197.6	210.8
63	13.4	26.8	40.2	53.6	66.9	80.3	93.7	107.1	120.5	133.9	147.3	160.7	174.0	187.4	200.8	214.2
64	13.6	27.2	40.8	54.4	68.0	81.6	95.2	108.8	122.4	136.0	149.6	163.2	176.8	190.4	204.0	217.6
65	13.8	27.6	41.4	55.3	69.1	82.9	96.7	110.5	124.3	138.1	151.9	165.8	179.6	193.4	207.2	221.0
66	14.0	28.1	42.1	56.1	70.1	84.2	98.2	112.2	126.2	140.3	154.3	168.3	182.3	196.4	210.4	224.4
67	14.2	28.5	42.7	57.0	71.2	85.4	99.7	113.9	128.1	142.4	156.6	170.9	185.1	199.3	213.6	227.8
68	14.5	28.9	43.4	57.8	72.3	86.7	101.2	115.6	130.1	144.5	159.0	173.4	187.9	202.3	216.8	231.2
69	14.7	29.3	44.0	58.7	73.3	88.0	102.6	117.3	132.0	146.6	161.3	176.0	190.6	205.3	219.9	234.6
70	14.9	29.8	44.6	59.5	74.4	89.3	104.1	119.0	133.9	148.8	163.6	178.5	193.4	208.3	223.1	238.0
71	15.1	30.2	45.3	60.4	75.4	90.5	105.6	120.7	135.8	150.9	166.0	181.1	196.1	211.2	226.3	241.4
72	15.3	30.6	45.9	61.2	76.5	91.8	107.1	122.4	137.7	153.0	168.3	183.6	198.9	214.2	229.5	244.8
73	15.5	31.0	46.5	62.1	77.6	93.1	108.6	124.1	139.6	155.1	170.6	186.2	201.7	217.2	232.7	248.2
74	15.7	31.5	47.2	62.9	78.6	94.4	110.1	125.8	141.5	157.3	173.0	188.7	204.4	220.2	235.9	251.6
75	15.9	31.9	47.8	63.8	79.7	95.6	111.6	127.5	143.4	159.4	175.3	191.3	207.2	223.1	239.1	255.0
76	16.2	32.3	48.5	64.6	80.8	96.9	113.1	129.2	145.4	161.5	177.7	193.8	210.0	226.1	242.3	258.4
77	16.4	32.7	49.1	65.4	81.8	98.2	114.5	130.9	147.3	163.6	180.0	196.4	212.7	229.1	245.4	261.8
78	16.6	33.2	49.7	66.3	82.9	99.5	116.0	132.6	149.2	165.8	182.3	198.9	215.5	232.1	248.6	265.2
79	16.8	33.6	50.4	67.2	83.9	100.7	117.5	134.3	151.1	167.9	184.7	201.5	218.2	235.0	251.8	268.6
80	17.0	34.0	51.0	68.0	85.0	102.0	119.0	136.0	153.0	170.0	187.0	204.0	221.0	238.0	255.0	272.0
81	17.2	34.4	51.6	68.9	86.1	103.3	120.5	137.7	154.9	172.1	189.3	206.6	223.8	241.0	258.2	275.4
82	17.4	34.9	52.3	69.7	87.1	104.6	122.0	139.4	156.8	174.3	191.7	209.1	226.5	244.0	261.4	278.8
	1/16	1/8	3/16	1/4	5/16	3/8	7/16	1/2	9/16	5/8	11/16	3/4	13/16	7/8	15/16	1

WEIGHTS OF FLAT ROLLED STEEL

POUNDS PER LINEAR FOOT

Width, Inches	THICKNESS, INCHES														1	
	1/16	1/8	3/16	1/4	5/16	3/8	7/16	1/2	9/16	5/8	11/16	3/4	13/16	7/8		15/16
83	17.6	35.3	52.9	70.6	88.2	105.8	123.5	141.1	158.7	176.4	194.0	211.7	229.3	246.9	264.6	282.2
84	17.9	35.7	53.6	71.4	89.3	107.1	125.0	142.8	160.7	178.5	196.4	214.2	232.1	249.9	267.8	285.6
85	18.1	36.1	54.2	72.3	90.3	108.4	126.4	144.5	162.6	180.6	198.7	216.8	234.8	252.9	270.9	289.0
86	18.3	36.6	54.8	73.1	91.4	109.7	127.9	146.2	164.5	182.8	201.0	219.3	237.6	255.9	274.1	292.4
87	18.5	37.0	55.5	74.0	92.4	110.9	129.4	147.9	166.4	184.9	203.4	221.9	240.3	258.8	277.3	295.8
88	18.7	37.4	56.1	74.8	93.5	112.2	130.9	149.6	168.3	187.0	205.7	224.4	243.1	261.8	280.5	299.2
89	18.9	37.8	56.7	75.7	94.6	113.5	132.4	151.3	170.2	189.1	208.0	227.0	245.9	264.8	283.7	302.6
90	19.1	38.3	57.4	76.5	95.6	114.8	133.9	153.0	172.1	191.3	210.4	229.5	248.6	267.8	286.9	306.0
91	19.3	38.7	58.0	77.4	96.7	116.0	135.4	154.7	174.0	193.4	212.7	232.1	251.4	270.7	290.1	309.4
92	19.6	39.1	58.7	78.2	97.8	117.3	136.9	156.4	176.0	195.5	215.1	234.6	254.2	273.7	293.3	312.8
93	19.8	39.5	59.3	79.1	98.8	118.6	138.3	158.1	177.9	197.6	217.4	237.2	256.9	276.7	296.4	316.2
94	20.0	40.0	59.9	79.9	99.9	119.9	139.8	159.8	179.8	199.8	219.7	239.7	259.7	279.7	299.6	319.6
95	20.2	40.4	60.6	80.8	100.9	121.1	141.3	161.5	181.7	201.9	222.1	242.3	262.4	282.6	302.8	323.0
96	20.4	40.8	61.2	81.6	102.0	122.4	142.8	163.2	183.6	204.0	224.4	244.8	265.2	285.6	306.0	326.4
97	20.6	41.2	61.8	82.5	103.1	123.7	144.3	164.9	185.5	206.1	226.7	247.4	268.0	288.6	309.2	329.8
98	20.8	41.7	62.5	83.3	104.1	125.0	145.8	166.6	187.4	208.3	229.1	249.9	270.7	291.6	312.4	333.2
99	21.0	42.1	63.1	84.2	105.2	126.2	147.3	168.3	189.3	210.4	231.4	252.5	273.5	294.5	315.6	336.6
100	21.3	42.5	63.8	85.0	106.3	127.5	148.8	170.0	191.3	212.5	233.8	255.0	276.3	297.5	318.8	340.0
101	21.5	42.9	64.4	85.9	107.3	128.8	150.2	171.7	193.2	214.6	236.1	257.6	279.0	300.5	321.9	343.4
102	21.7	43.4	65.0	86.7	108.4	130.0	151.7	173.4	195.1	216.8	238.4	260.1	281.8	303.5	325.1	346.8
103	21.9	43.8	65.7	87.6	109.4	131.3	153.2	175.1	197.0	218.9	240.8	262.7	284.5	306.4	328.3	350.2
104	22.1	44.2	66.3	88.4	110.5	132.6	154.7	176.8	198.9	221.0	243.1	265.2	287.3	309.4	331.5	353.6
105	22.3	44.6	66.9	89.3	111.6	133.9	156.2	178.5	200.8	223.1	245.4	267.8	290.1	312.4	334.7	357.0
106	22.5	45.1	67.6	90.1	112.6	135.2	157.7	180.2	202.7	225.3	247.8	270.3	292.8	315.4	337.9	360.4
107	22.7	45.5	68.2	91.0	113.7	136.4	159.2	181.9	204.6	227.4	250.1	272.9	295.6	318.3	341.1	363.8
108	23.0	45.9	68.9	91.8	114.8	137.7	160.7	183.6	206.6	229.5	252.5	275.4	298.4	321.3	344.3	367.2

ONE HALF TABULAR OVERRUNS OF SHEARED PLATES

To be used in figuring weights in accordance with the A.I.S.C. Code of Standard Practice.

These percentages are to be added to the weights of all sheared plates and to the weights of universal rolled plates less than 5'-0 in length.

Add 1.25% to the weights of universal rolled plates 5'-0 and over in length.

Thickness	Under 48 Inches	48 to 59 ¹⁵ / ₁₆	60 to 71 ¹⁵ / ₁₆	72 to 83 ¹⁵ / ₁₆	84 to 95 ¹⁵ / ₁₆	96 to 107 ¹⁵ / ₁₆	108 to 119 ¹⁵ / ₁₆	120 to 131 ¹⁵ / ₁₆	132 and Over	Thickness
1/16	4.5	5.	6.	7.						1/16
1/8	4.	4.5	5.	6.						1/8
3/16	3.5	4.	4.5	5.	6.					3/16
1/4	3.	3.5	4.	4.5	5.	6.	7.	8.	9.5	1/4
5/16	2.5	3.	3.5	4.	4.5	5.	6.	7.	8.5	5/16
3/8	2.25	2.5	3.	3.5	4.	4.5	5.	6.	7.5	3/8
7/16	2.	2.25	2.5	3.	3.5	4.	4.5	5.	6.5	7/16
1/2	1.75	2.	2.25	2.5	3.	3.5	4.	4.5	5.5	1/2
9/16	1.75	2.	2.25	2.5	3.	3.5	4.	4.5	5.5	9/16
5/8	1.5	1.75	2.	2.25	2.5	3.	3.5	4.	4.5	5/8
11/16	1.5	1.75	2.	2.25	2.5	3.	3.5	4.	4.5	11/16
3/4	1.25	1.5	1.75	2.	2.25	2.5	3.	3.5	4.	3/4
13/16	1.25	1.5	1.75	2.	2.25	2.5	3.	3.5	4.	13/16
7/8	1.25	1.5	1.75	2.	2.25	2.5	3.	3.5	4.	7/8
15/16	1.25	1.5	1.75	2.	2.25	2.5	3.	3.5	4.	15/16
1" and over	1.25	1.25	1.5	1.75	2.	2.25	2.5	3.	3.5	1" and over

Note: The above figures are 1/2 the percentages for overrun in weights of sheared plates as given by the Association of American Steel Manufacturers.

APPROXIMATE AREA OF IRREGULAR FIGURE

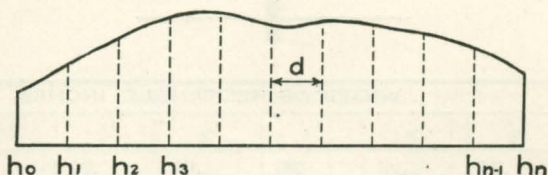

Simpson's Rule

Divide figure into an even number of strips of equal width by parallel ordinates, h_0, h_1, h_2 , etc.

$$\text{Area} = \frac{d}{3} [(h_0 + h_n) + 4(h_1 + h_3 + \dots h_{n-1}) + 2(h_2 + h_4 + \dots h_{n-2})]$$

SOLID OF REVOLUTION

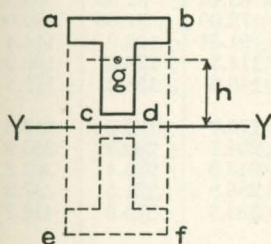

The volume of a solid of revolution equals the area of the generating plane multiplied by the length of the path described by the center of gravity of the plane.

For a complete revolution of the plane: Volume of solid abef = $2\pi h \times \text{area } abcd$.

TO REDUCE A POLYGON TO A TRIANGLE OF THE SAME AREA

USEFUL IN FIGURING WEIGHTS OF PLATES

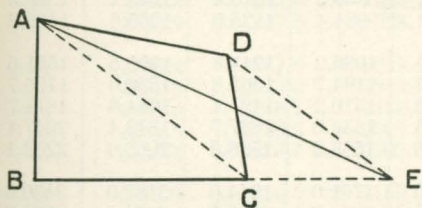

Draw Line AC

Draw Line DE parallel to AC

Connect A and E, forming $\triangle ABE$ whose area is equal to that of the quadrilateral ABCD

This method is applicable to a polygon of any number of sides, the above method reducing the number of sides by one each time it is used.

MOMENTS OF INERTIA OF RECTANGLES



Depth, Inches	WIDTH OF RECTANGLE, INCHES						
	$\frac{1}{4}$	$\frac{5}{16}$	$\frac{3}{8}$	$\frac{7}{16}$	$\frac{1}{2}$	$\frac{9}{16}$	$\frac{5}{8}$
1	.02	.03	.03	.04	.04	.05	.05
2	.17	.21	.25	.29	.33	.38	.42
3	.56	.70	.84	.98	1.13	1.27	1.41
4	1.33	1.67	2.00	2.33	2.67	3.00	3.33
5	2.60	3.26	3.91	4.56	5.21	5.86	6.51
6	4.50	5.63	6.75	7.88	9.00	10.13	11.25
7	7.15	8.93	10.72	12.51	14.29	16.08	17.86
8	10.67	13.33	16.00	18.67	21.33	24.00	26.67
9	15.19	18.98	22.78	26.58	30.38	34.17	37.97
10	20.83	26.04	31.25	36.46*	41.67	46.87	52.08
11	27.73	34.66	41.59	48.53	55.46	62.39	69.32
12	36.00	45.00	54.00	63.00	72.00	81.00	90.00
13	45.77	57.21	68.66	80.10	91.54	103.0	114.4
14	57.17	71.46	85.75	100.0	114.3	128.6	142.9
15	70.31	87.89	105.5	123.1	140.6	158.2	175.8
16	85.33	106.7	128.0	149.3	170.7	192.0	213.3
17	102.4	127.9	153.5	179.1	204.7	230.3	255.9
18	121.5	151.8	182.3	212.6	243.0	273.4	303.8
19	142.9	178.6	214.3	250.1	285.8	321.5	357.2
20	166.7	208.3	250.0	291.7	333.3	375.0	416.7
21	192.9	241.2	289.4	337.6	385.9	434.1	482.3
22	221.8	277.3	332.8	388.2	443.7	499.1	554.6
23	253.5	316.9	380.2	443.6	507.0	570.3	633.7
24	288.0	360.0	432.0	504.0	576.0	648.0	720.0
25	325.5	406.9	488.3	569.7	651.0	732.4	813.8
26	366.2	457.7	549.3	640.8	732.3	823.9	915.4
27	410.1	512.6	615.1	717.6	820.1	922.6	1025.2
28	457.3	571.7	686.0	800.3	914.7	1029.0	1143.3
29	508.1	635.1	762.2	889.2	1016.2	1143.2	1270.3
30	562.5	703.1	843.8	984.4	1125.0	1265.6	1406.3
31	620.7	775.8	931.0	1086.2	1241.3	1396.5	1551.6
32	682.7	853.3	1024.0	1194.7	1365.3	1536.0	1706.7
33	748.7	935.9	1123.0	1310.2	1497.4	1684.6	1871.7
34	818.8	1023.5	1228.3	1433.0	1637.7	1842.4	2047.1
35	893.2	1116.5	1339.8	1563.2	1786.5	2009.8	2233.1
36	972.0	1215.0	1458.0	1701.0	1944.0	2187.0	2430.0
37	1055.3	1319.1	1582.9	1846.7	2110.5	2374.4	2636.2
38	1143.2	1429.0	1714.8	2000.5	2286.3	2572.2	2857.9
39	1235.8	1544.8	1853.7	2162.7	2471.6	2780.6	3089.5
40	1333.3	1666.7	2000.0	2333.3	2666.7	3000.0	3333.3

MOMENTS OF INERTIA OF RECTANGLES



Depth, Inches	WIDTH OF RECTANGLE, INCHES					
	$\frac{1}{16}$	$\frac{3}{4}$	$\frac{13}{16}$	$\frac{7}{8}$	$\frac{5}{16}$	1
1	.06	.06	.07	.07	.08	.08
2	.46	.50	.54	.58	.63	.67
3	1.55	1.69	1.83	1.97	2.11	2.25
4	3.67	4.00	4.33	4.67	5.00	5.33
5	7.16	7.81	8.46	9.11	9.77	10.42
6	12.38	13.50	14.63	15.75	16.88	18.00
7	19.65	21.44	23.22	25.01	26.80	28.58
8	29.33	32.00	34.67	37.33	40.00	42.67
9	41.77	45.56	49.36	53.16	56.95	60.75
10	57.29	62.50	67.71	72.92	78.13	83.33
11	76.26	83.19	90.12	97.05	104.0	110.9
12	99.00	108.0	117.0	126.0	135.0	144.0
13	125.9	137.3	148.8	160.2	171.6	183.1
14	157.2	171.5	185.8	200.1	214.4	228.7
15	193.4	210.9	228.5	246.1	263.7	281.3
16	234.7	256.0	277.3	298.7	320.0	341.3
17	281.5	307.1	332.7	358.2	383.8	409.4
18	334.1	364.5	394.9	425.3	455.6	486.0
19	393.0	428.7	464.4	500.1	535.9	571.6
20	458.3	500.0	541.7	583.3	625.0	666.7
21	530.6	578.8	627.1	675.3	723.5	771.8
22	610.0	665.5	721.0	776.4	831.9	887.3
23	697.1	760.4	823.8	887.2	950.6	1013.9
24	792.0	864.0	936.0	1008.0	1080.0	1152.0
25	895.2	976.6	1057.9	1139.3	1220.7	1303.1
26	1007.0	1098.5	1190.0	1281.6	1373.1	1464.7
27	1127.7	1230.2	1332.7	1435.2	1537.7	1640.3
28	1257.7	1372.0	1486.4	1600.7	1715.0	1829.3
29	1397.3	1524.3	1651.3	1778.4	1905.4	2032.4
30	1546.9	1687.5	1828.1	1968.8	2109.4	2250.0
31	1706.8	1861.9	2017.1	2172.3	2327.4	2482.6
32	1877.3	2048.0	2218.7	2389.3	2560.0	2730.0
33	2058.9	2246.1	2433.2	2620.4	2807.6	2994.8
34	2251.8	2456.5	2661.2	2865.9	3070.6	3275.3
35	2456.4	2679.7	2903.0	3126.3	3349.6	3572.9
36	2673.0	2916.0	3159.0	3402.0	3645.0	3888.0
37	2902.0	3165.8	3429.6	3693.5	3957.3	4221.1
38	3143.7	3429.5	3715.3	4001.1	4286.9	4572.7
39	3398.5	3707.4	4016.4	4325.3	4634.3	4943.3
40	3666.7	4000.0	4333.3	4666.7	5000.0	5333.3

MOMENTS OF INERTIA OF RECTANGLES



Depth, Inches	WIDTH OF RECTANGLE, INCHES						
	$\frac{1}{4}$	$\frac{5}{16}$	$\frac{3}{8}$	$\frac{7}{16}$	$\frac{1}{2}$	$\frac{9}{16}$	$\frac{5}{8}$
41	1436	1795	2154	2513	2871	3231	3590
42	1544	1929	2315	2701	3087	3473	3859
43	1656	2071	2485	2899	3313	3727	4141
44	1775	2218	2662	3106	3549	3993	4437
45	1898	2373	2848	3322	3797	4271	4746
46	2028	2535	3042	3549	4056	4563	5070
47	2163	2704	3244	3785	4326	4867	5407
48	2304	2880	3456	4032	4608	5184	5760
49	2451	3064	3677	4289	4902	5515	6128
50	2604	3255	3906	4557	5208	5859	6510
52	2929	3662	4394	5126	5859	6591	7323
54	3281	4101	4921	5741	6561	7381	8201
56	3659	4573	5488	6403	7317	8232	9147
58	4065	5081	6097	7113	8130	9146	10162
60	4500	5625	6750	7875	9000	10125	11250
62	4965	6206	7448	8689	9930	11172	12413
64	5461	6827	8192	9557	10923	12288	13653
66	5990	7487	8984	10482	11979	13476	14974
68	6551	8188	9826	11464	13101	14739	16377
70	7146	8932	10719	12505	14292	16078	17865
72	7776	9720	11664	13608	15552	17496	19440
74	8442	10553	12663	14774	16884	18995	21105
76	9145	11432	13718	16004	18291	20577	22863
78	9887	12358	14830	17301	19773	22245	24716
80	10667	13333	16000	18667	21333	24000	26667
82	11487	14359	17230	20102	22974	25845	28717
84	12348	15435	18522	21609	24696	27783	30870
86	13251	16564	19877	23190	26502	29815	33128
88	14197	17747	21296	24845	28395	31944	35493
90	15188	18984	22781	26578	30375	34172	37969
92	16223	20278	24334	28390	32445	36501	40557
94	17304	21630	25956	30282	34608	38934	43260
96	18432	23040	27648	32256	36864	41472	46080
98	19608	24510	29412	34314	39216	44118	49020
100	20833	26042	31250	36458	41667	46875	52083
102	22109	27636	33163	38690	44217	49744	55271
104	23435	29293	35152	41011	46869	52728	58587
106	24813	31016	37219	43422	49626	55829	62032
108	26244	32805	39366	45927	52488	59049	65610
110	27729	34661	41954	48526	55458	62391	69323

MOMENTS OF INERTIA OF RECTANGLES



Depth, Inches	WIDTH OF RECTANGLE, INCHES					
	$\frac{1}{16}$	$\frac{3}{4}$	$\frac{13}{16}$	$\frac{7}{8}$	$\frac{15}{16}$	1
41	3949	4308	4667	5025	5384	5743
42	4245	4631	5016	5402	5788	6174
43	4555	4969	5383	5797	6211	6626
44	4880	5324	5768	6211	6655	7099
45	5221	5695	6170	6645	7119	7594
46	5577	6084	6590	7097	7604	8111
47	5948	6489	7030	7570	8111	8652
48	6336	6912	7488	8064	8640	9216
49	6740	7353	7966	8579	9191	9804
50	7161	7813	8464	9115	9766	10417
52	8056	8788	9520	10253	10985	11717
54	9021	9842	10662	11482	12302	13122
56	10061	10976	11891	12805	13720	14635
58	11178	12195	13211	14227	15243	16259
60	12375	13500	14625	15750	16875	18000
62	13654	14896	16137	17378	18619	19861
64	15019	16384	17749	19115	20480	21845
66	16471	17969	19466	20963	22461	23958
68	18014	19652	21290	22927	24565	26203
70	19651	21438	23224	25010	26797	28583
72	21384	23328	25272	27216	29160	31104
74	23216	25327	27437	29548	31658	33769
76	25150	27436	29722	32009	34295	36581
78	27188	29660	32131	34603	37074	39546
80	29333	32000	34667	37333	40000	42667
82	31589	34461	37332	40204	43076	45947
84	33957	37044	40131	43218	46305	49392
86	36441	39754	43066	46379	49692	53005
88	39043	42592	46141	49691	53240	56789
90	41766	45563	49349	53156	56953	60750
92	44612	48668	52724	56779	60835	64891
94	47586	51912	56237	60563	64889	69215
96	50688	55296	59904	64512	69120	73728
98	53922	58825	63727	68629	73531	78433
100	57292	62500	67708	72917	78125	83333
102	60798	66326	71853	77380	82907	88434
104	64445	70304	76163	82021	87880	93739
106	68235	74439	80642	86845	93048	99251
108	72170	78732	85293	91854	98415	104976
110	76255	83188	90120	97052	103984	110917

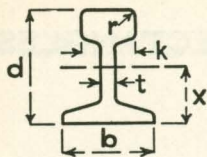

DIMENSIONS OF RAILS

Weight per Yard	Area	b	d	k	t	x	r
Pounds	Sq. Inches	Inches	Inches	Inches	Inch	Inches	Inch
130 P.S.	12.75	5½	6⅝	3	1⅛	3⅛	⅞
130 A.R.E.A.	12.75	6	6¾	2⅛	1⅛	3⅛	⅜
110 A.R.E.A.	10.78	5½	6¼	2¾	⅝	2⅜	⅜
105 N.Y.C.	10.29	5½	6	3	⅝	2⅝	⅝
100 A.S.C.E.	9.80	5¾	5¾	2¾	⅞	2½	⅝
100 P.S.	9.80	5	5⅛	2⅛	⅞	2½	⅞
100 A.R.A. (A.)	9.80	5½	6	2¾	⅞	2¾	⅜
100 A.R.A. (B.)	9.80	5⅛	5⅝	2⅝	⅞	2½	⅜
100 A.R.E.A.	9.80	5⅜	6	2⅛	⅞	2⅛	⅜
90 A.S.C.E.	8.82	5⅜	5⅜	2⅝	⅞	2⅜	⅝
90 A.R.A. (A.)	8.82	5⅛	5⅝	2⅞	⅞	2⅞	⅜
90 A.R.A. (B.)	8.82	4¾	5¼	2⅞	⅞	2⅜	⅜
85 A.S.C.E.	8.33	5⅞	5⅞	2⅞	⅞	2¼	⅝
85 P.R.R.	8.33	5	5	2⅞	⅞	2⅞	⅞
85 P.S.	8.33	4⅝	5⅞	2½	⅞	2¼	⅞
80 A.S.C.E.	7.84	5	5	2½	⅞	2⅜	⅝
75 A.S.C.E.	7.35	4⅜	4⅜	2⅞	⅞	2⅞	⅝
70 A.S.C.E.	6.86	4⅝	4⅝	2⅞	½	2⅞	⅝
65 A.S.C.E.	6.37	4⅞	4⅞	2⅜	½	2	⅝
60 A.S.C.E.	5.88	4¼	4¼	2⅜	½	1⅞	⅝
55 A.S.C.E.	5.39	4⅞	4⅞	2¼	½	1⅜	⅝
50 A.S.C.E.	4.90	3⅞	3⅞	2⅞	⅞	1¾	⅝
45 A.S.C.E.	4.41	3⅛	3⅛	2	⅞	1⅝	⅝
40 A.S.C.E.	3.92	3½	3½	1⅞	⅜	1⅞	⅝
35 A.S.C.E.	3.43	3⅞	3⅞	1¾	⅜	1½	⅝
30 A.S.C.E.	2.94	3⅞	3⅞	1⅛	⅝	1⅜	⅝
25 A.S.C.E.	2.45	2¾	2¾	1½	⅝	1¼	¼
20 A.S.C.E.	1.96	2⅝	2⅝	1⅞	¼	1⅞	¼
16 A.S.C.E.	1.57	2⅜	2⅜	1⅞	¼	1⅞	⅜
12 A.S.C.E.	1.18	2	2	1	⅞	⅞	⅜

**MATHEMATICAL
TABLES**

Degrees	NATURAL SINES							Co-sines
	0'	10'	20'	30'	40'	50'	60'	
0	0.0000	0.00291	0.00582	0.00873	0.01164	0.01454	0.01745	89
1	0.01745	0.02036	0.02327	0.02618	0.02908	0.03199	0.03490	88
2	0.03490	0.03781	0.04071	0.04362	0.04653	0.04943	0.05234	87
3	0.05234	0.05524	0.05814	0.06105	0.06395	0.06685	0.06976	86
4	0.06976	0.07266	0.07556	0.07846	0.08136	0.08426	0.08716	85
5	0.08716	0.09005	0.09295	0.09585	0.09874	0.10164	0.10453	84
6	0.10453	0.10742	0.11031	0.11320	0.11609	0.11898	0.12187	83
7	0.12187	0.12476	0.12764	0.13053	0.13341	0.13629	0.13917	82
8	0.13917	0.14205	0.14493	0.14781	0.15069	0.15356	0.15643	81
9	0.15643	0.15931	0.16218	0.16505	0.16792	0.17078	0.17365	80
10	0.17365	0.17651	0.17937	0.18224	0.18509	0.18795	0.19081	79
11	0.19081	0.19366	0.19652	0.19937	0.20222	0.20507	0.20791	78
12	0.20791	0.21076	0.21360	0.21644	0.21928	0.22212	0.22495	77
13	0.22495	0.22778	0.23062	0.23345	0.23627	0.23910	0.24192	76
14	0.24192	0.24474	0.24756	0.25038	0.25320	0.25601	0.25882	75
15	0.25882	0.26163	0.26443	0.26724	0.27004	0.27284	0.27564	74
16	0.27564	0.27843	0.28123	0.28402	0.28680	0.28959	0.29237	73
17	0.29237	0.29515	0.29793	0.30071	0.30348	0.30625	0.30902	72
18	0.30902	0.31178	0.31454	0.31730	0.32006	0.32282	0.32557	71
19	0.32557	0.32832	0.33106	0.33381	0.33655	0.33929	0.34202	70
20	0.34202	0.34475	0.34748	0.35021	0.35293	0.35565	0.35837	69
21	0.35837	0.36108	0.36379	0.36650	0.36921	0.37191	0.37461	68
22	0.37461	0.37730	0.37999	0.38268	0.38537	0.38805	0.39073	67
23	0.39073	0.39341	0.39608	0.39875	0.40142	0.40408	0.40674	66
24	0.40674	0.40939	0.41204	0.41469	0.41734	0.41998	0.42262	65
25	0.42262	0.42525	0.42788	0.43051	0.43313	0.43575	0.43837	64
26	0.43837	0.44098	0.44359	0.44620	0.44880	0.45140	0.45399	63
27	0.45399	0.45658	0.45917	0.46175	0.46433	0.46690	0.46947	62
28	0.46947	0.47204	0.47460	0.47716	0.47971	0.48226	0.48481	61
29	0.48481	0.48735	0.48989	0.49242	0.49495	0.49748	0.50000	60
30	0.50000	0.50252	0.50503	0.50754	0.51004	0.51254	0.51504	59
31	0.51504	0.51753	0.52002	0.52250	0.52498	0.52745	0.52992	58
32	0.52992	0.53238	0.53484	0.53730	0.53975	0.54220	0.54464	57
33	0.54464	0.54708	0.54951	0.55194	0.55436	0.55678	0.55919	56
34	0.55919	0.56160	0.56401	0.56641	0.56880	0.57119	0.57358	55
35	0.57358	0.57596	0.57833	0.58070	0.58307	0.58543	0.58779	54
36	0.58779	0.59014	0.59248	0.59482	0.59716	0.59949	0.60182	53
37	0.60182	0.60414	0.60645	0.60876	0.61107	0.61337	0.61566	52
38	0.61566	0.61795	0.62024	0.62251	0.62479	0.62706	0.62932	51
39	0.62932	0.63158	0.63383	0.63608	0.63832	0.64056	0.64279	50
40	0.64279	0.64501	0.64723	0.64945	0.65166	0.65386	0.65606	49
41	0.65606	0.65825	0.66044	0.66262	0.66480	0.66697	0.66913	48
42	0.66913	0.67129	0.67344	0.67559	0.67773	0.67987	0.68200	47
43	0.68200	0.68412	0.68624	0.68835	0.69046	0.69256	0.69466	46
44	0.69466	0.69675	0.69883	0.70091	0.70298	0.70505	0.70711	45
Sines	60'	50'	40'	30'	20'	10'	0'	Degrees

NATURAL COSINES

NATURAL COSINES

Degrees	NATURAL COSINES							Sines
	0'	10'	20'	30'	40'	50'	60'	
0	1.00000	1.00000	0.99998	0.99996	0.99993	0.99989	0.99985	89
1	0.99985	0.99979	0.99973	0.99966	0.99958	0.99949	0.99939	88
2	0.99939	0.99929	0.99917	0.99905	0.99892	0.99878	0.99863	87
3	0.99863	0.99847	0.99831	0.99813	0.99795	0.99776	0.99756	86
4	0.99756	0.99736	0.99714	0.99692	0.99668	0.99644	0.99619	85
5	0.99619	0.99594	0.99567	0.99540	0.99511	0.99482	0.99452	84
6	0.99452	0.99421	0.99390	0.99357	0.99324	0.99290	0.99255	83
7	0.99255	0.99219	0.99182	0.99144	0.99106	0.99067	0.99027	82
8	0.99027	0.98986	0.98944	0.98902	0.98858	0.98814	0.98769	81
9	0.98769	0.98723	0.98676	0.98629	0.98580	0.98531	0.98481	80
10	0.98481	0.98430	0.98378	0.98325	0.98272	0.98218	0.98163	79
11	0.98163	0.98107	0.98050	0.97992	0.97934	0.97875	0.97815	78
12	0.97815	0.97754	0.97692	0.97630	0.97566	0.97502	0.97437	77
13	0.97437	0.97371	0.97304	0.97237	0.97169	0.97100	0.97030	76
14	0.97030	0.96959	0.96887	0.96815	0.96742	0.96667	0.96593	75
15	0.96593	0.96517	0.96440	0.96363	0.96285	0.96206	0.96126	74
16	0.96126	0.96046	0.95964	0.95882	0.95799	0.95715	0.95630	73
17	0.95630	0.95545	0.95459	0.95372	0.95284	0.95195	0.95106	72
18	0.95106	0.95015	0.94924	0.94832	0.94740	0.94646	0.94552	71
19	0.94552	0.94457	0.94361	0.94264	0.94167	0.94068	0.93969	70
20	0.93969	0.93869	0.93769	0.93667	0.93565	0.93462	0.93358	69
21	0.93358	0.93253	0.93148	0.93042	0.92935	0.92827	0.92718	68
22	0.92718	0.92609	0.92499	0.92388	0.92276	0.92164	0.92050	67
23	0.92050	0.91936	0.91822	0.91706	0.91590	0.91472	0.91355	66
24	0.91355	0.91236	0.91116	0.90996	0.90875	0.90753	0.90631	65
25	0.90631	0.90507	0.90383	0.90259	0.90133	0.90007	0.89879	64
26	0.89879	0.89752	0.89623	0.89493	0.89363	0.89232	0.89101	63
27	0.89101	0.88968	0.88835	0.88701	0.88566	0.88431	0.88295	62
28	0.88295	0.88158	0.88020	0.87882	0.87743	0.87603	0.87462	61
29	0.87462	0.87321	0.87178	0.87036	0.86892	0.86748	0.86603	60
30	0.86603	0.86457	0.86310	0.86163	0.86015	0.85866	0.85717	59
31	0.85717	0.85567	0.85416	0.85264	0.85112	0.84959	0.84805	58
32	0.84805	0.84650	0.84495	0.84339	0.84182	0.84025	0.83867	57
33	0.83867	0.83708	0.83549	0.83389	0.83228	0.83066	0.82904	56
34	0.82904	0.82741	0.82577	0.82413	0.82248	0.82082	0.81915	55
35	0.81915	0.81748	0.81580	0.81412	0.81242	0.81072	0.80902	54
36	0.80902	0.80730	0.80558	0.80386	0.80212	0.80038	0.79864	53
37	0.79864	0.79688	0.79512	0.79335	0.79158	0.78980	0.78801	52
38	0.78801	0.78622	0.78442	0.78261	0.78079	0.77897	0.77715	51
39	0.77715	0.77531	0.77347	0.77162	0.76977	0.76791	0.76604	50
40	0.76604	0.76417	0.76229	0.76041	0.75851	0.75661	0.75471	49
41	0.75471	0.75280	0.75088	0.74896	0.74703	0.74509	0.74314	48
42	0.74314	0.74120	0.73924	0.73728	0.73531	0.73333	0.73135	47
43	0.73135	0.72937	0.72737	0.72537	0.72337	0.72136	0.71934	46
44	0.71934	0.71732	0.71529	0.71325	0.71121	0.70916	0.70711	45
Co-sines	60'	50'	40'	30'	20'	10'	0'	Degrees
	NATURAL SINES							

Degrees	NATURAL TANGENTS							Cotan- gents
	0'	10'	20'	30'	40'	50'	60'	
0	0.00000	0.00291	0.00582	0.00873	0.01164	0.01455	0.01746	89
1	0.01746	0.02036	0.02328	0.02619	0.02910	0.03201	0.03492	88
2	0.03492	0.03783	0.04075	0.04366	0.04658	0.04949	0.05241	87
3	0.05241	0.05533	0.05824	0.06116	0.06408	0.06700	0.06993	86
4	0.06993	0.07285	0.07578	0.07870	0.08163	0.08456	0.08749	85
5	0.08749	0.09042	0.09335	0.09629	0.09923	0.10216	0.10510	84
6	0.10510	0.10805	0.11099	0.11394	0.11688	0.11983	0.12278	83
7	0.12278	0.12574	0.12869	0.13165	0.13461	0.13758	0.14054	82
8	0.14054	0.14351	0.14648	0.14945	0.15243	0.15540	0.15838	81
9	0.15838	0.16137	0.16435	0.16734	0.17033	0.17333	0.17633	80
10	0.17633	0.17933	0.18233	0.18534	0.18835	0.19136	0.19438	79
11	0.19438	0.19740	0.20042	0.20345	0.20648	0.20952	0.21256	78
12	0.21256	0.21560	0.21864	0.22169	0.22475	0.22781	0.23087	77
13	0.23087	0.23393	0.23700	0.24008	0.24316	0.24624	0.24933	76
14	0.24933	0.25242	0.25552	0.25862	0.26172	0.26483	0.26795	75
15	0.26795	0.27107	0.27419	0.27732	0.28046	0.28360	0.28675	74
16	0.28675	0.28990	0.29305	0.29621	0.29938	0.30255	0.30573	73
17	0.30573	0.30891	0.31210	0.31530	0.31850	0.32171	0.32492	72
18	0.32492	0.32814	0.33136	0.33460	0.33783	0.34108	0.34433	71
19	0.34433	0.34758	0.35085	0.35412	0.35740	0.36068	0.36397	70
20	0.36397	0.36727	0.37057	0.37388	0.37720	0.38053	0.38386	69
21	0.38386	0.38721	0.39055	0.39391	0.39727	0.40065	0.40403	68
22	0.40403	0.40741	0.41081	0.41421	0.41763	0.42105	0.42447	67
23	0.42447	0.42791	0.43136	0.43481	0.43828	0.44175	0.44523	66
24	0.44523	0.44872	0.45222	0.45573	0.45924	0.46277	0.46631	65
25	0.46631	0.46985	0.47341	0.47698	0.48055	0.48414	0.48773	64
26	0.48773	0.49134	0.49495	0.49858	0.50222	0.50587	0.50953	63
27	0.50953	0.51320	0.51688	0.52057	0.52427	0.52798	0.53171	62
28	0.53171	0.53545	0.53920	0.54296	0.54673	0.55051	0.55431	61
29	0.55431	0.55812	0.56194	0.56577	0.56962	0.57348	0.57735	60
30	0.57735	0.58124	0.58513	0.58905	0.59297	0.59691	0.60086	59
31	0.60086	0.60483	0.60881	0.61280	0.61681	0.62083	0.62487	58
32	0.62487	0.62892	0.63299	0.63707	0.64117	0.64528	0.64941	57
33	0.64941	0.65355	0.65771	0.66189	0.66608	0.67028	0.67451	56
34	0.67451	0.67875	0.68301	0.68728	0.69157	0.69588	0.70021	55
35	0.70021	0.70455	0.70891	0.71329	0.71769	0.72211	0.72654	54
36	0.72654	0.73100	0.73547	0.73996	0.74447	0.74900	0.75355	53
37	0.75355	0.75812	0.76272	0.76733	0.77196	0.77661	0.78129	52
38	0.78129	0.78598	0.79070	0.79544	0.80020	0.80498	0.80978	51
39	0.80978	0.81461	0.81946	0.82434	0.82923	0.83415	0.83910	50
40	0.83910	0.84407	0.84906	0.85408	0.85912	0.86419	0.86929	49
41	0.86929	0.87441	0.87955	0.88473	0.88992	0.89515	0.90040	48
42	0.90040	0.90569	0.91099	0.91633	0.92170	0.92709	0.93252	47
43	0.93252	0.93797	0.94345	0.94896	0.95451	0.96008	0.96569	46
44	0.96569	0.97133	0.97700	0.98270	0.98843	0.99420	1.00000	45
Tan- gents	60'	50'	40'	30'	20'	10'	0'	Degrees
NATURAL COTANGENTS								

NATURAL COTANGENTS

Degrees	NATURAL COTANGENTS							Tan- gents
	0'	10'	20'	30'	40'	50'	60'	
0	∞	343.77371	171.88540	114.58865	85.93979	68.75009	57.28996	89
1	57.28996	49.10388	42.96408	38.18846	34.36777	31.24158	28.63625	88
2	28.63625	26.43160	24.54176	22.90377	21.47040	20.20555	19.08114	87
3	19.08114	18.07498	17.16934	16.34986	15.60478	14.92442	14.30067	86
4	14.30067	13.72674	13.19688	12.70621	12.25051	11.82617	11.43005	85
5	11.43005	11.05943	10.71191	10.38540	10.07803	9.78817	9.51436	84
6	9.51436	9.25530	9.00983	8.77689	8.55555	8.34496	8.14435	83
7	8.14435	7.95302	7.77035	7.59575	7.42871	7.26873	7.11537	82
8	7.11537	6.96823	6.82694	6.69116	6.56055	6.43484	6.31375	81
9	6.31375	6.19703	6.08444	5.97576	5.87080	5.76937	5.67128	80
10	5.67128	5.57638	5.48451	5.39552	5.30928	5.22566	5.14455	79
11	5.14455	5.06584	4.98940	4.91516	4.84300	4.77286	4.70463	78
12	4.70463	4.63825	4.57363	4.51071	4.44942	4.38969	4.33148	77
13	4.33148	4.27471	4.21933	4.16530	4.11256	4.06107	4.01078	76
14	4.01078	3.96165	3.91364	3.86671	3.82083	3.77595	3.73205	75
15	3.73205	3.68909	3.64705	3.60588	3.56557	3.52609	3.48741	74
16	3.48741	3.44951	3.41236	3.37594	3.34023	3.30521	3.27085	73
17	3.27085	3.23714	3.20406	3.17159	3.13972	3.10842	3.07768	72
18	3.07768	3.04749	3.01783	2.98869	2.96004	2.93189	2.90421	71
19	2.90421	2.87700	2.85023	2.82391	2.79802	2.77254	2.74748	70
20	2.74748	2.72281	2.69853	2.67462	2.65109	2.62791	2.60509	69
21	2.60509	2.58261	2.56046	2.53865	2.51715	2.49597	2.47509	68
22	2.47509	2.45451	2.43422	2.41421	2.39449	2.37504	2.35585	67
23	2.35585	2.33693	2.31826	2.29984	2.28167	2.26374	2.24604	66
24	2.24604	2.22857	2.21132	2.19430	2.17749	2.16090	2.14451	65
25	2.14451	2.12832	2.11233	2.09654	2.08094	2.06553	2.05030	64
26	2.05030	2.03526	2.02039	2.00569	1.99116	1.97680	1.96261	63
27	1.96261	1.94858	1.93470	1.92098	1.90741	1.89400	1.88073	62
28	1.88073	1.86760	1.85462	1.84177	1.82906	1.81649	1.80405	61
29	1.80405	1.79174	1.77955	1.76749	1.75556	1.74375	1.73205	60
30	1.73205	1.72047	1.70901	1.69766	1.68643	1.67530	1.66428	59
31	1.66428	1.65337	1.64256	1.63185	1.62125	1.61074	1.60033	58
32	1.60033	1.59002	1.57981	1.56969	1.55966	1.54972	1.53987	57
33	1.53987	1.53010	1.52043	1.51084	1.50133	1.49190	1.48256	56
34	1.48256	1.47330	1.46411	1.45501	1.44598	1.43703	1.42815	55
35	1.42815	1.41934	1.41061	1.40195	1.39336	1.38484	1.37638	54
36	1.37638	1.36800	1.35968	1.35142	1.34323	1.33511	1.32704	53
37	1.32704	1.31904	1.31110	1.30323	1.29541	1.28764	1.27994	52
38	1.27994	1.27230	1.26471	1.25717	1.24969	1.24227	1.23490	51
39	1.23490	1.22758	1.22031	1.21310	1.20593	1.19882	1.19175	50
40	1.19175	1.18474	1.17777	1.17085	1.16398	1.15715	1.15037	49
41	1.15037	1.14363	1.13694	1.13029	1.12369	1.11713	1.11061	48
42	1.11061	1.10414	1.09770	1.09131	1.08496	1.07864	1.07237	47
43	1.07237	1.06613	1.05994	1.05378	1.04766	1.04158	1.03553	46
44	1.03553	1.02952	1.02355	1.01761	1.01170	1.00583	1.00000	45

Cotan-
gents

NATURAL TANGENTS

Degrees

60'	50'	40'	30'	20'	10'	0'
-----	-----	-----	-----	-----	-----	----

Degrees	NATURAL SECANTS							Cose-cants
	0'	10'	20'	30'	40'	50'	60'	
0	1.00000	1.00000	1.00002	1.00004	1.00007	1.00011	1.00015	89
1	1.00015	1.00021	1.00027	1.00034	1.00042	1.00051	1.00061	88
2	1.00061	1.00072	1.00083	1.00095	1.00108	1.00122	1.00137	87
3	1.00137	1.00153	1.00169	1.00187	1.00205	1.00224	1.00244	86
4	1.00244	1.00265	1.00287	1.00309	1.00333	1.00357	1.00382	85
5	1.00382	1.00408	1.00435	1.00463	1.00491	1.00521	1.00551	84
6	1.00551	1.00582	1.00614	1.00647	1.00681	1.00715	1.00751	83
7	1.00751	1.00787	1.00825	1.00863	1.00902	1.00942	1.00983	82
8	1.00983	1.01024	1.01067	1.01111	1.01155	1.01200	1.01247	81
9	1.01247	1.01294	1.01342	1.01391	1.01440	1.01491	1.01543	80
10	1.01543	1.01595	1.01649	1.01703	1.01758	1.01815	1.01872	79
11	1.01872	1.01930	1.01989	1.02049	1.02110	1.02171	1.02234	78
12	1.02234	1.02298	1.02362	1.02428	1.02494	1.02562	1.02630	77
13	1.02630	1.02700	1.02770	1.02842	1.02914	1.02987	1.03061	76
14	1.03061	1.03137	1.03213	1.03290	1.03368	1.03447	1.03528	75
15	1.03528	1.03609	1.03691	1.03774	1.03858	1.03944	1.04030	74
16	1.04030	1.04117	1.04206	1.04295	1.04385	1.04477	1.04569	73
17	1.04569	1.04663	1.04757	1.04853	1.04950	1.05047	1.05146	72
18	1.05146	1.05246	1.05347	1.05449	1.05552	1.05657	1.05762	71
19	1.05762	1.05869	1.05976	1.06085	1.06195	1.06306	1.06418	70
20	1.06418	1.06531	1.06645	1.06761	1.06878	1.06995	1.07115	69
21	1.07115	1.07235	1.07356	1.07479	1.07602	1.07727	1.07853	68
22	1.07853	1.07981	1.08109	1.08239	1.08370	1.08503	1.08636	67
23	1.08636	1.08771	1.08907	1.09044	1.09183	1.09323	1.09464	66
24	1.09464	1.09606	1.09750	1.09895	1.10041	1.10189	1.10338	65
25	1.10338	1.10488	1.10640	1.10793	1.10947	1.11103	1.11260	64
26	1.11260	1.11419	1.11579	1.11740	1.11903	1.12067	1.12233	63
27	1.12233	1.12400	1.12568	1.12738	1.12910	1.13083	1.13257	62
28	1.13257	1.13433	1.13610	1.13789	1.13970	1.14152	1.14335	61
29	1.14335	1.14521	1.14707	1.14896	1.15085	1.15277	1.15470	60
30	1.15470	1.15665	1.15861	1.16059	1.16259	1.16460	1.16663	59
31	1.16663	1.16868	1.17075	1.17283	1.17493	1.17704	1.17918	58
32	1.17918	1.18133	1.18350	1.18569	1.18790	1.19012	1.19236	57
33	1.19236	1.19463	1.19691	1.19920	1.20152	1.20386	1.20622	56
34	1.20622	1.20859	1.21099	1.21341	1.21584	1.21830	1.22077	55
35	1.22077	1.22327	1.22579	1.22833	1.23089	1.23347	1.23607	54
36	1.23607	1.23869	1.24134	1.24400	1.24669	1.24940	1.25214	53
37	1.25214	1.25489	1.25767	1.26047	1.26330	1.26615	1.26902	52
38	1.26902	1.27191	1.27483	1.27778	1.28075	1.28374	1.28676	51
39	1.28676	1.28980	1.29287	1.29597	1.29909	1.30223	1.30541	50
40	1.30541	1.30861	1.31183	1.31509	1.31837	1.32168	1.32501	49
41	1.32501	1.32838	1.33177	1.33519	1.33864	1.34212	1.34563	48
42	1.34563	1.34917	1.35274	1.35634	1.35997	1.36363	1.36733	47
43	1.36733	1.37105	1.37481	1.37860	1.38242	1.38628	1.39016	46
44	1.39016	1.39409	1.39804	1.40203	1.40606	1.41012	1.41421	45
Se-cants	60'	50'	40'	30'	20'	10'	0'	Degrees
NATURAL COSECANTS								

NATURAL COSECANTS

Degrees	NATURAL COSECANTS							Se-cants
	0'	10'	20'	30'	40'	50'	60'	
0	∞	343.77516	171.88831	114.59301	85.94561	68.75736	57.29869	89
1	57.29869	49.11406	42.97571	38.20155	34.38232	31.25758	28.65371	88
2	28.65371	26.45051	24.56212	22.92559	21.49368	20.23028	19.10732	87
3	19.10732	18.10262	17.19843	16.38041	15.63679	14.95788	14.33559	86
4	14.33559	13.76312	13.23472	12.74550	12.29125	11.86837	11.47371	85
5	11.47371	11.10455	10.75849	10.43343	10.12752	9.83912	9.56677	84
6	9.56677	9.30917	9.06515	8.83367	8.61379	8.40466	8.20551	83
7	8.20551	8.01565	7.83443	7.66130	7.49571	7.33719	7.18530	82
8	7.18530	7.03962	6.89979	6.76547	6.63633	6.51208	6.39245	81
9	6.39245	6.27719	6.16607	6.05886	5.95536	5.85539	5.75877	80
10	5.75877	5.66533	5.57493	5.48740	5.40263	5.32049	5.24084	79
11	5.24084	5.16359	5.08863	5.01585	4.94517	4.87649	4.80973	78
12	4.80973	4.74482	4.68167	4.62023	4.56041	4.50216	4.44541	77
13	4.44541	4.39012	4.33622	4.28366	4.23239	4.18238	4.13357	76
14	4.13357	4.08591	4.03938	3.99393	3.94952	3.90613	3.86370	75
15	3.86370	3.82223	3.78166	3.74198	3.70315	3.66515	3.62796	74
16	3.62796	3.59154	3.55587	3.52094	3.48671	3.45317	3.42030	73
17	3.42030	3.38808	3.35649	3.32551	3.29512	3.26531	3.23607	72
18	3.23607	3.20737	3.17920	3.15155	3.12440	3.09774	3.07155	71
19	3.07155	3.04584	3.02057	2.99574	2.97135	2.94737	2.92380	70
20	2.92380	2.90063	2.87785	2.85545	2.83342	2.81175	2.79043	69
21	2.79043	2.76945	2.74881	2.72850	2.70851	2.68884	2.66947	68
22	2.66947	2.65040	2.63162	2.61313	2.59491	2.57698	2.55930	67
23	2.55930	2.54190	2.52474	2.50784	2.49119	2.47477	2.45859	66
24	2.45859	2.44264	2.42692	2.41142	2.39614	2.38107	2.36620	65
25	2.36620	2.35154	2.33708	2.32282	2.30875	2.29487	2.28117	64
26	2.28117	2.26766	2.25432	2.24116	2.22817	2.21535	2.20269	63
27	2.20269	2.19019	2.17786	2.16568	2.15366	2.14178	2.13005	62
28	2.13005	2.11847	2.10704	2.09574	2.08458	2.07356	2.06267	61
29	2.06267	2.05191	2.04128	2.03077	2.02039	2.01014	2.00000	60
30	2.00000	1.98998	1.98008	1.97029	1.96062	1.95106	1.94160	59
31	1.94160	1.93226	1.92302	1.91388	1.90485	1.89591	1.88710	58
32	1.88710	1.87834	1.86970	1.86116	1.85271	1.84435	1.83608	57
33	1.83608	1.82790	1.81981	1.81180	1.80388	1.79604	1.78829	56
34	1.78829	1.78062	1.77303	1.76552	1.75808	1.75073	1.74345	55
35	1.74345	1.73624	1.72911	1.72205	1.71506	1.70815	1.70130	54
36	1.70130	1.69452	1.68782	1.68117	1.67460	1.66809	1.66164	53
37	1.66164	1.65526	1.64894	1.64268	1.63648	1.63035	1.62427	52
38	1.62427	1.61825	1.61229	1.60639	1.60054	1.59475	1.58902	51
39	1.58902	1.58333	1.57771	1.57213	1.56661	1.56114	1.55572	50
40	1.55572	1.55036	1.54504	1.53977	1.53455	1.52938	1.52425	49
41	1.52425	1.51918	1.51415	1.50916	1.50422	1.49933	1.49448	48
42	1.49448	1.48967	1.48491	1.48019	1.47551	1.47087	1.46628	47
43	1.46628	1.46173	1.45721	1.45274	1.44831	1.44391	1.43956	46
44	1.43956	1.43524	1.43096	1.42672	1.42251	1.41835	1.41421	45
Cose-cants	60'	50'	40'	30'	20'	10'	0'	Degrees

NATURAL SECANTS

LENGTH OF CIRCULAR ARCS

WHEN CHORD AND RISE ARE KNOWN

Height	Length	Height	Length	Height	Length	Height	Length
.001	1.00002	.068	1.01228	.122	1.03923	.176	1.08066
.005	1.00007	.070	1.01301	.124	1.04051	.178	1.08246
.010	1.00027	.072	1.01376	.126	1.04181	.180	1.08428
.015	1.00061	.074	1.01453	.128	1.04313	.182	1.08611
.020	1.00107	.076	1.01533	.130	1.04447	.184	1.08797
.023	1.00140	.078	1.01614	.132	1.04584	.186	1.08984
.026	1.00182	.080	1.01698	.134	1.04722	.188	1.09174
.028	1.00210	.082	1.01784	.136	1.04862	.190	1.09365
.030	1.00240	.084	1.01872	.138	1.05003	.192	1.09557
.032	1.00272	.086	1.01961	.140	1.05147	.194	1.09752
.034	1.00307	.088	1.02052	.142	1.05293	.196	1.09949
.036	1.00345	.090	1.02146	.144	1.05441	.198	1.10147
.038	1.00384	.092	1.02240	.146	1.05591	.200	1.10347
.040	1.00426	.094	1.02339	.148	1.05743	.202	1.10548
.042	1.00469	.096	1.02440	.150	1.05896	.204	1.10752
.044	1.00515	.098	1.02542	.152	1.06051	.206	1.10958
.046	1.00563	.100	1.02646	.154	1.06209	.208	1.11165
.048	1.00612	.102	1.02752	.156	1.06368	.210	1.11374
.050	1.00665	.104	1.02860	.158	1.06530	.212	1.11584
.052	1.00720	.106	1.02970	.160	1.06693	.214	1.11796
.054	1.00776	.108	1.03082	.162	1.06858	.216	1.12011
.056	1.00834	.110	1.03196	.164	1.07025	.218	1.12225
.058	1.00895	.112	1.03312	.166	1.07194	.220	1.12444
.060	1.00957	.114	1.03430	.168	1.07365	.222	1.12664
.062	1.01021	.116	1.03551	.170	1.07537	.224	1.12885
.064	1.01088	.118	1.03672	.172	1.07711	.226	1.13108
.066	1.01158	.120	1.03797	.174	1.07888	.228	1.13331

To find the length of a circular arc, when chord and height are given.

Rule:—Divide the height by the chord; find in the column of heights the number equal to this quotient; take out the corresponding number from the column of lengths; and multiply this number by the given chord.

Problem: Chord of an arc = 90 and height = 20. What is the length of the arc?

Solution: $20 \div 90 = 0.222$. Length of arc for height of 0.222 is, from table, 1.12664. $90 \times 1.12664 = 101.3976 =$ length of arc.

LENGTH OF CIRCULAR ARCS (CONTINUED)

WHEN CHORD AND RISE ARE KNOWN

Height	Length	Height	Length	Height	Length	Height	Length
.230	1.13557	.298	1.22213	.366	1.32577	.434	1.44405
.232	1.13785	.300	1.22495	.368	1.32905	.436	1.44773
.234	1.14015	.302	1.22778	.370	1.33234	.438	1.45142
.236	1.14247	.304	1.23063	.372	1.33564	.440	1.45512
.238	1.14480	.306	1.23349	.374	1.33896	.442	1.45883
.240	1.14714	.308	1.23636	.376	1.34229	.444	1.46255
.242	1.14951	.310	1.23926	.378	1.34563	.446	1.46628
.244	1.15189	.312	1.24216	.380	1.34899	.448	1.47002
.246	1.15428	.314	1.24507	.382	1.35237	.450	1.47377
.248	1.15670	.316	1.24801	.384	1.35575	.452	1.47753
.250	1.15912	.318	1.25095	.386	1.35914	.454	1.48131
.252	1.16156	.320	1.25391	.388	1.36254	.456	1.48509
.254	1.16402	.322	1.25689	.390	1.36596	.458	1.48889
.256	1.16650	.324	1.25988	.392	1.36939	.460	1.49269
.258	1.16899	.326	1.26288	.394	1.37283	.462	1.49651
.260	1.17150	.328	1.26588	.396	1.37628	.464	1.50033
.262	1.17403	.330	1.26892	.398	1.37974	.466	1.50416
.264	1.17657	.332	1.27196	.400	1.38322	.468	1.50800
.266	1.17912	.334	1.27502	.402	1.38671	.470	1.51185
.268	1.18169	.336	1.27810	.404	1.39021	.472	1.51571
.270	1.18429	.338	1.28118	.406	1.39372	.474	1.51958
.272	1.18689	.340	1.28428	.408	1.39724	.476	1.52346
.274	1.18951	.342	1.28739	.410	1.40077	.478	1.52736
.276	1.19214	.344	1.29052	.412	1.40432	.480	1.53126
.278	1.19479	.346	1.29366	.414	1.40788	.482	1.53518
.280	1.19746	.348	1.29681	.416	1.41145	.484	1.53910
.282	1.20014	.350	1.29997	.418	1.41503	.486	1.54302
.284	1.20284	.352	1.30315	.420	1.41861	.488	1.54696
.286	1.20555	.354	1.30634	.422	1.42221	.490	1.55091
.288	1.20827	.356	1.30954	.424	1.42583	.492	1.55487
.290	1.21102	.358	1.31276	.426	1.42945	.494	1.55884
.292	1.21377	.360	1.31599	.428	1.43309	.496	1.56282
.294	1.21654	.362	1.31923	.430	1.43673	.498	1.56681
.296	1.21933	.364	1.32249	.432	1.44039	.500	1.57080

AREA OF CIRCULAR SECTIONS

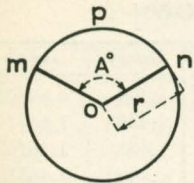

CIRCULAR SECTOR, monp

$$\begin{aligned} \text{Area} &= \frac{1}{2} (\text{length of arc, mpn} \times \text{radius, } r) \\ &= \text{area of circle} \times \frac{\text{angle } A, \text{ in degrees}}{360} \\ &= 0.0087266 \times r^2 \times \text{angle } A, \text{ in degrees} \end{aligned}$$

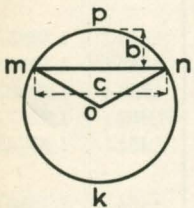

CIRCULAR SEGMENT, mpn, LESS THAN HALF CIRCLE

$$\begin{aligned} \text{Area} &= \text{area sector, monp} - \text{area of triangle, mon} \\ &= \frac{(\text{length of arc, mpn} \times r) - c(r-b)}{2} \end{aligned}$$

CIRCULAR SEGMENT, mkn, GREATER THAN HALF CIRCLE

$$\text{Area} = \text{area of circle} - \text{area of segment, mpn}$$

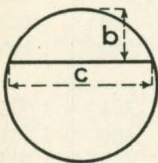

CIRCULAR SEGMENT, FROM TABLE 1, PAGE 163

Given: Rise, b , and chord, c .

Area = $b \times c$, multiplied by coefficient given opposite quotient of $\frac{b}{c}$. Interpolate for values not given.

Example: Given, rise = 1.483, and chord = 4.12

$$\frac{b}{c} = \frac{1.483}{4.12} = 0.36 \quad \text{Coefficient} = .7314$$

$$\text{Area} = b \times c \times \text{Coeff.} = 1.483 \times 4.12 \times .7314 = 4.4688$$

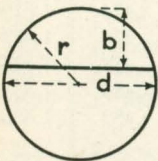

CIRCULAR SEGMENT, FROM TABLE 2, PAGES 164, 165

Given: Rise, b , and diameter, $d = 2r$

Area = square of diameter, d^2 , multiplied by the coefficient given opposite quotient of $\frac{b}{d}$. Interpolate for values not given.

Example: Given, rise = $2\frac{7}{16}$ and diameter = $5\frac{3}{32}$

$$\frac{b}{d} = 2\frac{7}{16} \div 5\frac{3}{32} = 0.478528 \quad \text{Coeff. by interpolation} = 0.371233$$

$$\text{Area} = d^2 \times \text{coeff.} = 25.94629 \times 0.371233 = 9.6321$$

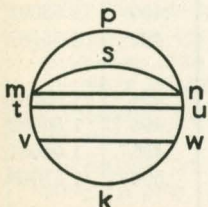

CIRCULAR ZONE, tuvw

$$\text{Area} = \text{area of circle} - (\text{area of segment, tpu} + \text{area of segment, vkw})$$

CIRCULAR LUNE, mpns

$$\text{Area} = \text{segment, mpn} - \text{segment, msn}$$

AREAS OF CIRCULAR SEGMENTS
TABLE 1, FOR RATIOS OF RISE AND CHORD

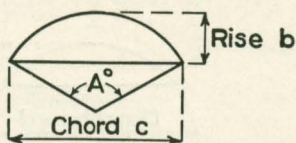

A°	Coefficient	$\frac{b}{c}$	A°	Coefficient	$\frac{b}{c}$	A°	Coefficient	$\frac{b}{c}$	A°	Coefficient	$\frac{b}{c}$
1	.6667	.0022	46	.6722	.1017	91	.6895	.2097	136	.7239	.3373
2	.6667	.0044	47	.6724	.1040	92	.6901	.2122	137	.7249	.3404
3	.6667	.0066	48	.6727	.1063	93	.6906	.2148	138	.7260	.3436
4	.6667	.0087	49	.6729	.1086	94	.6912	.2174	139	.7270	.3469
5	.6667	.0109	50	.6732	.1109	95	.6918	.2200	140	.7281	.3501
6	.6667	.0131	51	.6734	.1131	96	.6924	.2226	141	.7292	.3534
7	.6668	.0153	52	.6737	.1154	97	.6930	.2252	142	.7303	.3567
8	.6668	.0175	53	.6740	.1177	98	.6936	.2279	143	.7314	.3600
9	.6669	.0197	54	.6743	.1200	99	.6942	.2305	144	.7325	.3633
10	.6670	.0218	55	.6746	.1224	100	.6948	.2332	145	.7336	.3666
11	.6670	.0240	56	.6749	.1247	101	.6954	.2358	146	.7348	.3700
12	.6671	.0262	57	.6752	.1270	102	.6961	.2385	147	.7360	.3734
13	.6672	.0284	58	.6755	.1293	103	.6967	.2412	148	.7372	.3768
14	.6672	.0306	59	.6758	.1316	104	.6974	.2439	149	.7384	.3802
15	.6673	.0328	60	.6761	.1340	105	.6980	.2466	150	.7396	.3837
16	.6674	.0350	61	.6764	.1363	106	.6987	.2493	151	.7408	.3871
17	.6674	.0372	62	.6768	.1387	107	.6994	.2520	152	.7421	.3906
18	.6675	.0394	63	.6771	.1410	108	.7001	.2548	153	.7434	.3942
19	.6676	.0416	64	.6775	.1434	109	.7008	.2575	154	.7447	.3977
20	.6677	.0437	65	.6779	.1457	110	.7015	.2603	155	.7460	.4013
21	.6678	.0459	66	.6782	.1481	111	.7022	.2631	156	.7473	.4049
22	.6679	.0481	67	.6786	.1505	112	.7030	.2659	157	.7486	.4085
23	.6680	.0504	68	.6790	.1529	113	.7037	.2687	158	.7500	.4122
24	.6681	.0526	69	.6794	.1553	114	.7045	.2715	159	.7514	.4159
25	.6682	.0548	70	.6797	.1577	115	.7052	.2743	160	.7528	.4196
26	.6684	.0570	71	.6801	.1601	116	.7060	.2772	161	.7542	.4233
27	.6685	.0592	72	.6805	.1625	117	.7068	.2800	162	.7557	.4270
28	.6687	.0614	73	.6809	.1649	118	.7076	.2829	163	.7571	.4308
29	.6688	.0636	74	.6814	.1673	119	.7084	.2858	164	.7586	.4346
30	.6690	.0658	75	.6818	.1697	120	.7092	.2887	165	.7601	.4385
31	.6691	.0681	76	.6822	.1722	121	.7100	.2916	166	.7616	.4424
32	.6693	.0703	77	.6826	.1746	122	.7109	.2945	167	.7632	.4463
33	.6694	.0725	78	.6831	.1771	123	.7117	.2975	168	.7648	.4502
34	.6696	.0747	79	.6835	.1795	124	.7126	.3004	169	.7664	.4542
35	.6698	.0770	80	.6840	.1820	125	.7134	.3034	170	.7680	.4582
36	.6700	.0792	81	.6844	.1845	126	.7143	.3064	171	.7696	.4622
37	.6702	.0814	82	.6849	.1869	127	.7152	.3094	172	.7712	.4663
38	.6704	.0837	83	.6854	.1894	128	.7161	.3124	173	.7729	.4704
39	.6706	.0859	84	.6859	.1919	129	.7170	.3155	174	.7746	.4745
40	.6708	.0882	85	.6864	.1944	130	.7180	.3185	175	.7763	.4787
41	.6710	.0904	86	.6869	.1970	131	.7189	.3216	176	.7781	.4828
42	.6712	.0927	87	.6874	.1995	132	.7199	.3247	177	.7799	.4871
43	.6714	.0949	88	.6879	.2020	133	.7209	.3278	178	.7817	.4914
44	.6717	.0972	89	.6884	.2046	134	.7219	.3309	179	.7835	.4957
45	.6719	.0995	90	.6890	.2071	135	.7229	.3341	180	.7854	.5000

AREAS OF CIRCULAR SEGMENTS

TABLE 2, FOR RATIOS OF RISE AND DIAMETER

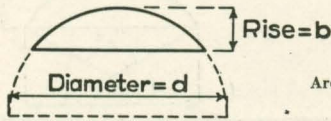

$$\text{Area} = d^2 \times \text{Coefficient}$$

$\frac{b}{d}$	Coefficient	$\frac{b}{d}$	Coefficient	$\frac{b}{d}$	Coefficient	$\frac{b}{d}$	Coefficient	$\frac{b}{d}$	Coefficient
.001	.000042	.051	.015119	.101	.041477	.151	.074590	.201	.112625
.002	.000119	.052	.015561	.102	.042081	.152	.075307	.202	.113427
.003	.000219	.053	.016008	.103	.042687	.153	.076026	.203	.114231
.004	.000337	.054	.016458	.104	.043296	.154	.076747	.204	.115036
.005	.000471	.055	.016912	.105	.043908	.155	.077470	.205	.115842
.006	.000619	.056	.017369	.106	.044523	.156	.078194	.206	.116651
.007	.000779	.057	.017831	.107	.045140	.157	.078921	.207	.117460
.008	.000952	.058	.018297	.108	.045759	.158	.079650	.208	.118271
.009	.001135	.059	.018766	.109	.046381	.159	.080380	.209	.119084
.010	.001329	.060	.019239	.110	.047006	.160	.081112	.210	.119898
.011	.001533	.061	.019716	.111	.047633	.161	.081847	.211	.120713
.012	.001746	.062	.020197	.112	.048262	.162	.082582	.212	.121530
.013	.001969	.063	.020681	.113	.048894	.163	.083320	.213	.122348
.014	.002199	.064	.021168	.114	.049529	.164	.084060	.214	.123167
.015	.002438	.065	.021660	.115	.050165	.165	.084801	.215	.123988
.016	.002685	.066	.022155	.116	.050805	.166	.085545	.216	.124811
.017	.002940	.067	.022653	.117	.051446	.167	.086290	.217	.125634
.018	.003202	.068	.023155	.118	.052090	.168	.087037	.218	.126459
.019	.003472	.069	.023660	.119	.052737	.169	.087785	.219	.127286
.020	.003749	.070	.024168	.120	.053385	.170	.088536	.220	.128114
.021	.004032	.071	.024680	.121	.054037	.171	.089288	.221	.128943
.022	.004322	.072	.025196	.122	.054690	.172	.090042	.222	.129773
.023	.004619	.073	.025714	.123	.055346	.173	.090797	.223	.130605
.024	.004922	.074	.026236	.124	.056004	.174	.091555	.224	.131438
.025	.005231	.075	.026761	.125	.056664	.175	.092314	.225	.132273
.026	.005546	.076	.027290	.126	.057327	.176	.093074	.226	.133109
.027	.005867	.077	.027821	.127	.057991	.177	.093837	.227	.133946
.028	.006194	.078	.028356	.128	.058658	.178	.094601	.228	.134784
.029	.006527	.079	.028894	.129	.059328	.179	.095367	.229	.135624
.030	.006866	.080	.029435	.130	.059999	.180	.096135	.230	.136465
.031	.007209	.081	.029979	.131	.060673	.181	.096904	.231	.137307
.032	.007559	.082	.030526	.132	.061349	.182	.097675	.232	.138151
.033	.007913	.083	.031077	.133	.062027	.183	.098447	.233	.138996
.034	.008273	.084	.031630	.134	.062707	.184	.099221	.234	.139842
.035	.008638	.085	.032186	.135	.063389	.185	.099997	.235	.140689
.036	.009008	.086	.032746	.136	.064074	.186	.100774	.236	.141538
.037	.009383	.087	.033308	.137	.064761	.187	.101553	.237	.142388
.038	.009764	.088	.033873	.138	.065449	.188	.102334	.238	.143239
.039	.010148	.089	.034441	.139	.066140	.189	.103116	.239	.144091
.040	.010538	.090	.035012	.140	.066833	.190	.103900	.240	.144945
.041	.010932	.091	.035586	.141	.067528	.191	.104686	.241	.145800
.042	.011331	.092	.036162	.142	.068225	.192	.105472	.242	.146656
.043	.011734	.093	.036742	.143	.068924	.193	.106261	.243	.147513
.044	.012142	.094	.037324	.144	.069626	.194	.107051	.244	.148371
.045	.012555	.095	.037909	.145	.070329	.195	.107843	.245	.149231
.046	.012971	.096	.038497	.146	.071034	.196	.108636	.246	.150091
.047	.013393	.097	.039087	.147	.071741	.197	.109431	.247	.150953
.048	.013818	.098	.039681	.148	.072450	.198	.110227	.248	.151816
.049	.014248	.099	.040277	.149	.073162	.199	.111025	.249	.152681
.050	.014681	.100	.040875	.150	.073875	.200	.111824	.250	.153546

AREAS OF CIRCULAR SEGMENTS
TABLE 2, FOR RATIOS OF RISE AND DIAMETER

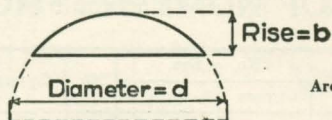

$$\text{Area} = d^2 \times \text{Coefficient}$$

$\frac{b}{d}$	Coefficient	$\frac{b}{d}$	Coefficient	$\frac{b}{d}$	Coefficient	$\frac{b}{d}$	Coefficient	$\frac{b}{d}$	Coefficient
.251	.154413	.301	.199085	.351	.245935	.401	.294350	.451	.343778
.252	.155281	.302	.200003	.352	.246890	.402	.295330	.452	.344773
.253	.156149	.303	.200922	.353	.247845	.403	.296311	.453	.345768
.254	.157019	.304	.201841	.354	.248801	.404	.297292	.454	.346764
.255	.157891	.305	.202762	.355	.249758	.405	.298274	.455	.347760
.256	.158763	.306	.203683	.356	.250715	.406	.299256	.456	.348756
.257	.159636	.307	.204605	.357	.251673	.407	.300238	.457	.349752
.258	.160511	.308	.205528	.358	.252632	.408	.301221	.458	.350749
.259	.161386	.309	.206452	.359	.253591	.409	.302204	.459	.351745
.260	.162263	.310	.207376	.360	.254551	.410	.303187	.460	.352742
.261	.163141	.311	.208302	.361	.255511	.411	.304171	.461	.353739
.262	.164020	.312	.209228	.362	.256472	.412	.305156	.462	.354736
.263	.164900	.313	.210155	.363	.257433	.413	.306140	.463	.355733
.264	.165781	.314	.211083	.364	.258395	.414	.307125	.464	.356730
.265	.166663	.315	.212011	.365	.259358	.415	.308110	.465	.357728
.266	.167546	.316	.212941	.366	.260321	.416	.309096	.466	.358725
.267	.168431	.317	.213871	.367	.261285	.417	.310082	.467	.359723
.268	.169316	.318	.214802	.368	.262249	.418	.311068	.468	.360721
.269	.170202	.319	.215734	.369	.263214	.419	.312055	.469	.361719
.270	.171090	.320	.216666	.370	.264179	.420	.313042	.470	.362717
.271	.171978	.321	.217600	.371	.265145	.421	.314029	.471	.363715
.272	.172868	.322	.218534	.372	.266111	.422	.315017	.472	.364714
.273	.173758	.323	.219469	.373	.267078	.423	.316005	.473	.365712
.274	.174650	.324	.220404	.374	.268046	.424	.316993	.474	.366711
.275	.175542	.325	.221341	.375	.269014	.425	.317981	.475	.367710
.276	.176436	.326	.222278	.376	.269982	.426	.318970	.476	.368708
.277	.177330	.327	.223216	.377	.270951	.427	.319959	.477	.369707
.278	.178226	.328	.224154	.378	.271921	.428	.320949	.478	.370706
.279	.179122	.329	.225094	.379	.272891	.429	.321938	.479	.371705
.280	.180020	.330	.226034	.380	.273861	.430	.322928	.480	.372704
.281	.180918	.331	.226974	.381	.274832	.431	.323919	.481	.373704
.282	.181818	.332	.227916	.382	.275804	.432	.324909	.482	.374703
.283	.182718	.333	.228858	.383	.276776	.433	.325900	.483	.375702
.284	.183619	.334	.229801	.384	.277748	.434	.326891	.484	.376702
.285	.184522	.335	.230745	.385	.278721	.435	.327883	.485	.377701
.286	.185425	.336	.231689	.386	.279695	.436	.328874	.486	.378701
.287	.186329	.337	.232634	.387	.280669	.437	.329866	.487	.379701
.288	.187235	.338	.233580	.388	.281643	.438	.330858	.488	.380700
.289	.188141	.339	.234526	.389	.282618	.439	.331851	.489	.381700
.290	.189048	.340	.235473	.390	.283593	.440	.332843	.490	.382700
.291	.189956	.341	.236421	.391	.284569	.441	.333836	.491	.383700
.292	.190865	.342	.237369	.392	.285545	.442	.334829	.492	.384699
.293	.191774	.343	.238319	.393	.286521	.443	.335823	.493	.385699
.294	.192685	.344	.239268	.394	.287499	.444	.336816	.494	.386699
.295	.193597	.345	.240219	.395	.288476	.445	.337810	.495	.387699
.296	.194509	.346	.241170	.396	.289454	.446	.338804	.496	.388699
.297	.195423	.347	.242122	.397	.290432	.447	.339799	.497	.389699
.298	.196337	.348	.243074	.398	.291411	.448	.340793	.498	.390699
.299	.197252	.349	.244027	.399	.292390	.449	.341788	.499	.391699
.300	.198168	.350	.244980	.400	.293370	.450	.342783	.500	.392699

SQUARES, SQUARE ROOTS, CIRCUMFERENCES AND CIRCULAR AREAS OF NUMBERS FROM 1 TO 1000

No.	Square	Square Root	No. = Dia.		No.	Square	Square Root	No. = Dia.	
			Circum.	Area				Circum.	Area
1	1	1.0000	3.142	0.7854	41	1681	6.4031	128.81	1320.25
2	4	1.4142	6.283	3.1416	42	1764	6.4807	131.95	1385.44
3	9	1.7321	9.425	7.0686	43	1849	6.5574	135.09	1452.20
4	16	2.0000	12.566	12.5664	44	1936	6.6332	138.23	1520.53
5	25	2.2361	15.708	19.6350	45	2025	6.7082	141.37	1590.43
6	36	2.4495	18.850	28.2743	46	2116	6.7823	144.51	1661.90
7	49	2.6458	21.991	38.4845	47	2209	6.8557	147.65	1734.94
8	64	2.8284	25.133	50.2655	48	2304	6.9282	150.80	1809.56
9	81	3.0000	28.274	63.6173	49	2401	7.0000	153.94	1885.74
10	100	3.1623	31.416	78.5398	50	2500	7.0711	157.08	1963.50
11	121	3.3166	34.558	95.0332	51	2601	7.1414	160.22	2042.82
12	144	3.4641	37.699	113.097	52	2704	7.2111	163.36	2123.72
13	169	3.6056	40.841	132.732	53	2809	7.2801	166.50	2206.18
14	196	3.7417	43.982	153.938	54	2916	7.3485	169.65	2290.22
15	225	3.8730	47.124	176.715	55	3025	7.4162	172.79	2375.83
16	256	4.0000	50.265	201.062	56	3136	7.4833	175.93	2463.01
17	289	4.1231	53.407	226.980	57	3249	7.5498	179.07	2551.76
18	324	4.2426	56.549	254.469	58	3364	7.6158	182.21	2642.08
19	361	4.3589	59.690	283.529	59	3481	7.6811	185.35	2733.97
20	400	4.4721	62.832	314.159	60	3600	7.7460	188.50	2827.43
21	441	4.5826	65.973	346.361	61	3721	7.8102	191.64	2922.47
22	484	4.6904	69.115	380.133	62	3844	7.8740	194.78	3019.07
23	529	4.7958	72.257	415.476	63	3969	7.9373	197.92	3117.25
24	576	4.8990	75.398	452.389	64	4096	8.0000	201.06	3216.99
25	625	5.0000	78.540	490.874	65	4225	8.0623	204.20	3318.31
26	676	5.0990	81.681	530.929	66	4356	8.1240	207.35	3421.19
27	729	5.1962	84.823	572.555	67	4489	8.1854	210.49	3525.65
28	784	5.2915	87.965	615.752	68	4624	8.2462	213.63	3631.68
29	841	5.3852	91.106	660.520	69	4761	8.3066	216.77	3739.28
30	900	5.4772	94.248	706.858	70	4900	8.3666	219.91	3848.45
31	961	5.5678	97.389	754.768	71	5041	8.4261	223.05	3959.19
32	1024	5.6569	100.531	804.248	72	5184	8.4853	226.19	4071.50
33	1089	5.7446	103.673	855.299	73	5329	8.5440	229.34	4185.39
34	1156	5.8310	106.814	907.920	74	5476	8.6023	232.48	4300.84
35	1225	5.9161	109.956	962.113	75	5625	8.6603	235.62	4417.86
36	1296	6.0000	113.097	1017.88	76	5776	8.7178	238.76	4536.46
37	1369	6.0828	116.239	1075.21	77	5929	8.7750	241.90	4656.63
38	1444	6.1644	119.381	1134.11	78	6084	8.8318	245.04	4778.36
39	1521	6.2450	122.522	1194.59	79	6241	8.8882	248.19	4901.67
40	1600	6.3246	125.66	1256.64	80	6400	8.9443	251.33	5026.55

SQUARES, SQUARE ROOTS, CIRCUMFERENCES AND CIRCULAR AREAS OF NUMBERS FROM 1 TO 1000

No.	Square	Square Root	No. = Dia.		No.	Square	Square Root	No. = Dia.	
			Circum.	Area				Circum.	Area
81	6561	9.0000	254.47	5153.00	121	14641	11.0000	380.13	11499.0
82	6724	9.0554	257.61	5281.02	122	14884	11.0454	383.27	11689.9
83	6889	9.1104	260.75	5410.61	123	15129	11.0905	386.42	11882.3
84	7056	9.1652	263.89	5541.77	124	15376	11.1355	389.56	12076.3
85	7225	9.2195	267.04	5674.50	125	15625	11.1803	392.70	12271.8
86	7396	9.2736	270.18	5808.80	126	15876	11.2250	395.84	12469.0
87	7569	9.3274	273.32	5944.68	127	16129	11.2694	398.98	12667.7
88	7744	9.3808	276.46	6082.12	128	16384	11.3137	402.12	12868.0
89	7921	9.4340	279.60	6221.14	129	16641	11.3578	405.27	13069.8
90	8100	9.4868	282.74	6361.73	130	16900	11.4018	408.41	13273.2
91	8281	9.5394	285.88	6503.88	131	17161	11.4455	411.55	13478.2
92	8464	9.5917	289.03	6647.61	132	17424	11.4891	414.69	13684.8
93	8649	9.6437	292.17	6792.91	133	17689	11.5326	417.83	13892.9
94	8836	9.6954	295.31	6939.78	134	17956	11.5758	420.97	14102.6
95	9025	9.7468	298.45	7088.22	135	18225	11.6190	424.12	14313.9
96	9216	9.7980	301.59	7238.23	136	18496	11.6619	427.26	14526.7
97	9409	9.8489	304.73	7389.81	137	18769	11.7047	430.40	14741.1
98	9604	9.8995	307.88	7542.96	138	19044	11.7473	433.54	14957.1
99	9801	9.9499	311.02	7697.69	139	19321	11.7898	436.68	15174.7
100	10000	10.0000	314.16	7853.98	140	19600	11.8322	439.82	15393.8
101	10201	10.0499	317.30	8011.85	141	19881	11.8743	442.96	15614.5
102	10404	10.0995	320.44	8171.28	142	20164	11.9164	446.11	15836.8
103	10609	10.1489	323.58	8332.29	143	20449	11.9583	449.25	16060.6
104	10816	10.1980	326.73	8494.87	144	20736	12.0000	452.39	16286.0
105	11025	10.2470	329.87	8659.01	145	21025	12.0416	455.53	16513.0
106	11236	10.2956	333.01	8824.73	146	21316	12.0830	458.67	16741.5
107	11449	10.3441	336.15	8992.02	147	21609	12.1244	461.81	16971.7
108	11664	10.3923	339.29	9160.88	148	21904	12.1655	464.96	17203.4
109	11881	10.4403	342.43	9331.32	149	22201	12.2066	468.10	17436.6
110	12100	10.4881	345.58	9503.32	150	22500	12.2474	471.24	17671.5
111	12321	10.5357	348.72	9676.89	151	22801	12.2882	474.38	17907.9
112	12544	10.5830	351.86	9852.03	152	23104	12.3288	477.52	18145.8
113	12769	10.6301	355.00	10028.7	153	23409	12.3693	480.66	18385.4
114	12996	10.6771	358.14	10207.0	154	23716	12.4097	483.81	18626.5
115	13225	10.7238	361.28	10386.9	155	24025	12.4499	486.95	18869.2
116	13456	10.7703	364.42	10568.3	156	24336	12.4900	490.09	19113.4
117	13689	10.8167	367.57	10751.3	157	24649	12.5300	493.23	19359.3
118	13924	10.8628	370.71	10935.9	158	24964	12.5698	496.37	19606.7
119	14161	10.9087	373.85	11122.0	159	25281	12.6095	499.51	19855.7
120	14400	10.9545	376.99	11309.7	160	25600	12.6491	502.65	20106.2

SQUARES, SQUARE ROOTS, CIRCUMFERENCES AND CIRCULAR AREAS OF NUMBERS FROM 1 TO 1000

No.	Square	Square Root	No. = Dia.		No.	Square	Square Root	No. = Dia.	
			Circum.	Area				Circum.	Area
161	25921	12.6886	505.80	20358.3	201	40401	14.1774	631.46	31730.9
162	26244	12.7279	508.94	20612.0	202	40804	14.2127	634.60	32047.4
163	26569	12.7671	512.08	20867.2	203	41209	14.2478	637.74	32365.5
164	26896	12.8062	515.22	21124.1	204	41616	14.2829	640.88	32685.1
165	27225	12.8452	518.36	21382.5	205	42025	14.3178	644.03	33006.4
166	27556	12.8841	521.50	21642.4	206	42436	14.3527	647.17	33329.2
167	27889	12.9228	524.65	21904.0	207	42849	14.3875	650.31	33653.5
168	28224	12.9615	527.79	22167.1	208	43264	14.4222	653.45	33979.5
169	28561	13.0000	530.93	22431.8	209	43681	14.4568	656.59	34307.0
170	28900	13.0384	534.07	22698.0	210	44100	14.4914	659.73	34636.1
171	29241	13.0767	537.21	22965.8	211	44521	14.5258	662.88	34966.7
172	29584	13.1149	540.35	23235.2	212	44944	14.5602	666.02	35298.9
173	29929	13.1529	543.50	23506.2	213	45369	14.5945	669.16	35632.7
174	30276	13.1909	546.64	23778.7	214	45796	14.6287	672.30	35968.1
175	30625	13.2288	549.78	24052.8	215	46225	14.6629	675.44	36305.0
176	30976	13.2665	552.92	24328.5	216	46656	14.6969	678.58	36643.5
177	31329	13.3041	556.06	24605.7	217	47089	14.7309	681.73	36983.6
178	31684	13.3417	559.20	24884.6	218	47524	14.7648	684.87	37325.3
179	32041	13.3791	562.35	25164.9	219	47961	14.7986	688.01	37668.5
180	32400	13.4164	565.49	25446.9	220	48400	14.8324	691.15	38013.3
181	32761	13.4536	568.63	25730.4	221	48841	14.8661	694.29	38359.6
182	33124	13.4907	571.77	26015.5	222	49284	14.8997	697.43	38707.6
183	33489	13.5277	574.91	26302.2	223	49729	14.9332	700.58	39057.1
184	33856	13.5647	578.05	26590.4	224	50176	14.9666	703.72	39408.1
185	34225	13.6015	581.19	26880.3	225	50625	15.0000	706.86	39760.8
186	34596	13.6382	584.34	27171.6	226	51076	15.0333	710.00	40115.0
187	34969	13.6748	587.48	27464.6	227	51529	15.0665	713.14	40470.8
188	35344	13.7113	590.62	27759.1	228	51984	15.0997	716.28	40828.1
189	35721	13.7477	593.76	28055.2	229	52441	15.1327	719.42	41187.1
190	36100	13.7840	596.90	28352.9	230	52900	15.1658	722.57	41547.6
191	36481	13.8203	600.04	28652.1	231	53361	15.1987	725.71	41909.6
192	36864	13.8564	603.19	28952.9	232	53824	15.2315	728.85	42273.3
193	37249	13.8924	606.33	29255.3	233	54289	15.2643	731.99	42638.5
194	37636	13.9284	609.47	29559.2	234	54756	15.2971	735.13	43005.3
195	38025	13.9642	612.61	29864.8	235	55225	15.3297	738.27	43373.6
196	38416	14.0000	615.75	30171.9	236	55696	15.3623	741.42	43743.5
197	38809	14.0357	618.89	30480.5	237	56169	15.3948	744.56	44115.0
198	39204	14.0712	622.04	30790.7	238	56644	15.4272	747.70	44488.1
199	39601	14.1067	625.18	31102.6	239	57121	15.4596	750.84	44862.7
200	40000	14.1421	628.32	31415.9	240	57600	15.4919	753.98	45238.9

SQUARES, SQUARE ROOTS, CIRCUMFERENCES AND CIRCULAR AREAS OF NUMBERS FROM 1 TO 1000

No.	Square	Square Root	No. = Dia.		No.	Square	Square Root	No. = Dia.	
			Circum.	Area				Circum.	Area
241	58081	15.5242	757.12	45616.7	281	78961	16.7631	882.79	62015.8
242	58564	15.5563	760.27	45996.1	282	79524	16.7929	885.93	62458.0
243	59049	15.5885	763.41	46377.0	283	80089	16.8226	889.07	62901.8
244	59536	15.6205	766.55	46759.5	284	80656	16.8523	892.21	63347.1
245	60025	15.6525	769.69	47143.5	285	81225	16.8819	895.35	63794.0
246	60516	15.6844	772.83	47529.2	286	81796	16.9115	898.50	64242.4
247	61009	15.7162	775.97	47916.4	287	82369	16.9411	901.64	64692.5
248	61504	15.7480	779.12	48305.1	288	82944	16.9706	904.78	65144.1
249	62001	15.7797	782.26	48695.5	289	83521	17.0000	907.92	65597.2
250	62500	15.8114	785.40	49087.4	290	84100	17.0294	911.06	66052.0
251	63001	15.8430	788.54	49480.9	291	84681	17.0587	914.20	66508.3
252	63504	15.8745	791.68	49875.9	292	85264	17.0880	917.35	66966.2
253	64009	15.9060	794.82	50272.6	293	85849	17.1172	920.49	67425.6
254	64516	15.9374	797.96	50670.7	294	86436	17.1464	923.63	67886.7
255	65025	15.9687	801.11	51070.5	295	87025	17.1756	926.77	68349.3
256	65536	16.0000	804.25	51471.9	296	87616	17.2047	929.91	68813.4
257	66049	16.0312	807.39	51874.8	297	88209	17.2337	933.05	69279.2
258	66564	16.0624	810.53	52279.2	298	88804	17.2627	936.19	69746.5
259	67081	16.0935	813.67	52685.3	299	89401	17.2916	939.34	70215.4
260	67600	16.1245	816.81	53092.9	300	90000	17.3205	942.48	70685.8
261	68121	16.1555	819.96	53502.1	301	90601	17.3494	945.62	71157.9
262	68644	16.1864	823.10	53912.9	302	91204	17.3781	948.76	71631.5
263	69169	16.2173	826.24	54325.2	303	91809	17.4069	951.90	72106.6
264	69696	16.2481	829.38	54739.1	304	92416	17.4356	955.04	72583.4
265	70225	16.2788	832.52	55154.6	305	93025	17.4642	958.19	73061.7
266	70756	16.3095	835.66	55571.6	306	93636	17.4929	961.33	73541.5
267	71289	16.3401	838.81	55990.2	307	94249	17.5214	964.47	74023.0
268	71824	16.3707	841.95	56410.4	308	94864	17.5499	967.61	74506.0
269	72361	16.4012	845.09	56832.2	309	95481	17.5784	970.75	74990.6
270	72900	16.4317	848.23	57255.5	310	96100	17.6068	973.89	75476.8
271	73441	16.4621	851.37	57680.4	311	96721	17.6352	977.04	75964.5
272	73984	16.4924	854.51	58106.9	312	97344	17.6635	980.18	76453.8
273	74529	16.5227	857.65	58534.9	313	97969	17.6918	983.32	76944.7
274	75076	16.5529	860.80	58964.6	314	98596	17.7200	986.46	77437.1
275	75625	16.5831	863.94	59395.7	315	99225	17.7482	989.60	77931.1
276	76176	16.6132	867.08	59828.5	316	99856	17.7764	992.74	78426.7
277	76729	16.6433	870.22	60262.8	317	100489	17.8045	995.88	78923.9
278	77284	16.6733	873.36	60698.7	318	101124	17.8326	999.03	79422.6
279	77841	16.7033	876.50	61136.2	319	101761	17.8606	1002.2	79922.9
280	78400	16.7332	879.65	61575.2	320	102400	17.8885	1005.3	80424.8

SQUARES, SQUARE ROOTS, CIRCUMFERENCES AND CIRCULAR AREAS OF NUMBERS FROM 1 TO 1000

No.	Square	Square Root	No. = Dia.		No.	Square	Square Root	No. = Dia.	
			Circum.	Area				Circum.	Area
321	103041	17.9165	1008.5	80928.2	361	130321	19.0000	1134.1	102354
322	103684	17.9444	1011.6	81433.2	362	131044	19.0263	1137.3	102922
323	104329	17.9722	1014.7	81939.8	363	131769	19.0526	1140.4	103491
324	104976	18.0000	1017.9	82448.0	364	132496	19.0788	1143.5	104062
325	105625	18.0278	1021.0	82957.7	365	133225	19.1050	1146.7	104635
326	106276	18.0555	1024.2	83469.0	366	133956	19.1311	1149.8	105209
327	106929	18.0831	1027.3	83981.8	367	134689	19.1572	1153.0	105785
328	107584	18.1108	1030.4	84496.3	368	135424	19.1833	1156.1	106362
329	108241	18.1384	1033.6	85012.3	369	136161	19.2094	1159.2	106941
330	108900	18.1659	1036.7	85529.9	370	136900	19.2354	1162.4	107521
331	109561	18.1934	1039.9	86049.0	371	137641	19.2614	1165.5	108103
332	110224	18.2209	1043.0	86569.7	372	138384	19.2873	1168.7	108687
333	110889	18.2483	1046.2	87092.0	373	139129	19.3132	1171.8	109272
334	111556	18.2757	1049.3	87615.9	374	139876	19.3391	1175.0	109858
335	112225	18.3030	1052.4	88141.3	375	140625	19.3649	1178.1	110447
336	112896	18.3303	1055.6	88668.3	376	141376	19.3907	1181.2	111036
337	113569	18.3576	1058.7	89196.9	377	142129	19.4165	1184.4	111628
338	114244	18.3848	1061.9	89727.0	378	142884	19.4422	1187.5	112221
339	114921	18.4120	1065.0	90258.7	379	143641	19.4679	1190.7	112815
340	115600	18.4391	1068.1	90792.0	380	144400	19.4936	1193.8	113411
341	116281	18.4662	1071.3	91326.9	381	145161	19.5192	1196.9	114009
342	116964	18.4932	1074.4	91863.3	382	145924	19.5448	1200.1	114608
343	117649	18.5203	1077.6	92401.3	383	146689	19.5704	1203.2	115209
344	118336	18.5472	1080.7	92940.9	384	147456	19.5959	1206.4	115812
345	119025	18.5742	1083.8	93482.0	385	148225	19.6214	1209.5	116416
346	119716	18.6011	1087.0	94024.7	386	148996	19.6469	1212.7	117021
347	120409	18.6279	1090.1	94569.0	387	149769	19.6723	1215.8	117628
348	121104	18.6548	1093.3	95114.9	388	150544	19.6977	1218.9	118237
349	121801	18.6815	1096.4	95662.3	389	151321	19.7231	1222.1	118847
350	122500	18.7083	1099.6	96211.3	390	152100	19.7484	1225.2	119459
351	123201	18.7350	1102.7	96761.8	391	152881	19.7737	1228.4	120072
352	123904	18.7617	1105.8	97314.0	392	153664	19.7990	1231.5	120687
353	124609	18.7883	1109.0	97867.7	393	154449	19.8242	1234.6	121304
354	125316	18.8149	1112.1	98423.0	394	155236	19.8494	1237.8	121922
355	126025	18.8414	1115.3	98979.8	395	156025	19.8746	1240.9	122542
356	126736	18.8680	1118.4	99538.2	396	156816	19.8997	1244.1	123163
357	127449	18.8944	1121.5	100098	397	157609	19.9249	1247.2	123786
358	128164	18.9209	1124.7	100660	398	158404	19.9499	1250.4	124410
359	128881	18.9473	1127.8	101223	399	159201	19.9750	1253.5	125036
360	129600	18.9737	1131.0	101788	400	160000	20.0000	1256.6	125664

SQUARES, SQUARE ROOTS, CIRCUMFERENCES AND CIRCULAR AREAS OF NUMBERS FROM 1 TO 1000

No.	Square	Square Root	No. = Dia.		No.	Square	Square Root	No. = Dia.	
			Circum.	Area				Circum.	Area
401	160801	20.0250	1259.8	126293	441	194481	21.0000	1385.4	152745
402	161604	20.0499	1262.9	126923	442	195364	21.0238	1388.6	153439
403	162409	20.0749	1266.1	127556	443	196249	21.0476	1391.7	154134
404	163216	20.0998	1269.2	128190	444	197136	21.0713	1394.9	154830
405	164025	20.1246	1272.3	128825	445	198025	21.0950	1398.0	155528
406	164836	20.1494	1275.5	129462	446	198916	21.1187	1401.2	156228
407	165649	20.1742	1278.6	130100	447	199809	21.1424	1404.3	156930
408	166464	20.1990	1281.8	130741	448	200704	21.1660	1407.4	157633
409	167281	20.2237	1284.9	131382	449	201601	21.1896	1410.6	158337
410	168100	20.2485	1288.1	132025	450	202500	21.2132	1413.7	159043
411	168921	20.2731	1291.2	132670	451	203401	21.2368	1416.9	159751
412	169744	20.2978	1294.3	133317	452	204304	21.2603	1420.0	160460
413	170569	20.3224	1297.5	133965	453	205209	21.2838	1423.1	161171
414	171396	20.3470	1300.6	134614	454	206116	21.3073	1426.3	161883
415	172225	20.3715	1303.8	135265	455	207025	21.3307	1429.4	162597
416	173056	20.3961	1306.9	135918	456	207936	21.3542	1432.6	163313
417	173889	20.4206	1310.0	136572	457	208849	21.3776	1435.7	164030
418	174724	20.4450	1313.2	137228	458	209764	21.4009	1438.8	164748
419	175561	20.4695	1316.3	137885	459	210681	21.4243	1442.0	165468
420	176400	20.4939	1319.5	138544	460	211600	21.4476	1445.1	166190
421	177241	20.5183	1322.6	139205	461	212521	21.4709	1448.3	166914
422	178084	20.5426	1325.8	139867	462	213444	21.4942	1451.4	167639
423	178929	20.5670	1328.9	140531	463	214369	21.5174	1454.6	168365
424	179776	20.5913	1332.0	141196	464	215296	21.5407	1457.7	169093
425	180625	20.6155	1335.2	141863	465	216225	21.5639	1460.8	169823
426	181476	20.6398	1338.3	142531	466	217156	21.5870	1464.0	170554
427	182329	20.6640	1341.5	143201	467	218089	21.6102	1467.1	171287
428	183184	20.6882	1344.6	143872	468	219024	21.6333	1470.3	172021
429	184041	20.7123	1347.7	144545	469	219961	21.6564	1473.4	172757
430	184900	20.7364	1350.9	145220	470	220900	21.6795	1476.5	173494
431	185761	20.7605	1354.0	145896	471	221841	21.7025	1479.7	174234
432	186624	20.7846	1357.2	146574	472	222784	21.7256	1482.8	174974
433	187489	20.8087	1360.3	147254	473	223729	21.7486	1486.0	175716
434	188356	20.8327	1363.5	147934	474	224676	21.7715	1489.1	176460
435	189225	20.8567	1366.6	148617	475	225625	21.7945	1492.3	177205
436	190096	20.8806	1369.7	149301	476	226576	21.8174	1495.4	177952
437	190969	20.9045	1372.9	149987	477	227529	21.8403	1498.5	178701
438	191844	20.9284	1376.0	150674	478	228484	21.8632	1501.7	179451
439	192721	20.9523	1379.2	151363	479	229441	21.8861	1504.8	180203
440	193600	20.9762	1382.3	152053	480	230400	21.9089	1508.0	180956

SQUARES, SQUARE ROOTS, CIRCUMFERENCES AND CIRCULAR AREAS OF NUMBERS FROM 1 TO 1000

No.	Square	Square Root	No. = Dia.		No.	Square	Square Root	No. = Dia.	
			Circum.	Area				Circum.	Area
481	231361	21.9317	1511.1	181711	521	271441	22.8254	1636.8	213189
482	232324	21.9545	1514.2	182467	522	272484	22.8473	1639.9	214008
483	233289	21.9773	1517.4	183225	523	273529	22.8692	1643.1	214829
484	234256	22.0000	1520.5	183984	524	274576	22.8910	1646.2	215651
485	235225	22.0227	1523.7	184745	525	275625	22.9129	1649.3	216475
486	236196	22.0454	1526.8	185508	526	276676	22.9347	1652.5	217301
487	237169	22.0681	1530.0	186272	527	277729	22.9565	1655.6	218128
488	238144	22.0907	1533.1	187038	528	278784	22.9783	1658.8	218956
489	239121	22.1133	1536.2	187805	529	279841	23.0000	1661.9	219787
490	240100	22.1359	1539.4	188574	530	280900	23.0217	1665.0	220618
491	241081	22.1585	1542.5	189345	531	281961	23.0434	1668.2	221452
492	242064	22.1811	1545.7	190117	532	283024	23.0651	1671.3	222287
493	243049	22.2036	1548.8	190890	533	284089	23.0868	1674.5	223123
494	244036	22.2261	1551.9	191665	534	285156	23.1084	1677.6	223961
495	245025	22.2486	1555.1	192442	535	286225	23.1301	1680.8	224801
496	246016	22.2711	1558.2	193221	536	287296	23.1517	1683.9	225642
497	247009	22.2935	1561.4	194000	537	288369	23.1733	1687.0	226484
498	248004	22.3159	1564.5	194782	538	289444	23.1948	1690.2	227329
499	249001	22.3383	1567.7	195565	539	290521	23.2164	1693.3	228175
500	250000	22.3607	1570.8	196350	540	291600	23.2379	1696.5	229022
501	251001	22.3830	1573.9	197136	541	292681	23.2594	1699.6	229871
502	252004	22.4054	1577.1	197923	542	293764	23.2809	1702.7	230722
503	253009	22.4277	1580.2	198713	543	294849	23.3024	1705.9	231574
504	254016	22.4499	1583.4	199504	544	295936	23.3238	1709.0	232428
505	255025	22.4722	1586.5	200296	545	297025	23.3452	1712.2	233283
506	256036	22.4944	1589.6	201090	546	298116	23.3666	1715.3	234140
507	257049	22.5167	1592.8	201886	547	299209	23.3880	1718.5	234998
508	258064	22.5389	1595.9	202683	548	300304	23.4094	1721.6	235858
509	259081	22.5610	1599.1	203482	549	301401	23.4307	1724.7	236720
510	260100	22.5832	1602.2	204282	550	302500	23.4521	1727.9	237583
511	261121	22.6053	1605.4	205084	551	303601	23.4734	1731.0	238448
512	262144	22.6274	1608.5	205887	552	304704	23.4947	1734.2	239314
513	263169	22.6495	1611.6	206692	553	305809	23.5160	1737.3	240182
514	264196	22.6716	1614.8	207499	554	306916	23.5372	1740.4	241051
515	265225	22.6936	1617.9	208307	555	308025	23.5584	1743.6	241922
516	266256	22.7156	1621.1	209117	556	309136	23.5797	1746.7	242795
517	267289	22.7376	1624.2	209928	557	310249	23.6008	1749.9	243669
518	268324	22.7596	1627.3	210741	558	311364	23.6220	1753.0	244545
519	269361	22.7816	1630.5	211556	559	312481	23.6432	1756.2	245422
520	270400	22.8035	1633.6	212372	560	313600	23.6643	1759.3	246301

SQUARES, SQUARE ROOTS, CIRCUMFERENCES AND CIRCULAR AREAS OF NUMBERS FROM 1 TO 1000

No.	Square	Square Root	No. = Dia.		No.	Square	Square Root	No. = Dia.	
			Circum.	Area				Circum.	Area
561	314721	23.6854	1762.4	247181	601	361201	24.5153	1888.1	283687
562	315844	23.7065	1765.6	248063	602	362404	24.5357	1891.2	284631
563	316969	23.7276	1768.7	248947	603	363609	24.5561	1894.4	285578
564	318096	23.7487	1771.9	249832	604	364816	24.5764	1897.5	286526
565	319225	23.7697	1775.0	250719	605	366025	24.5967	1900.7	287475
566	320356	23.7908	1778.1	251607	606	367236	24.6171	1903.8	288426
567	321489	23.8118	1781.3	252497	607	368449	24.6374	1906.9	289379
568	322624	23.8328	1784.4	253388	608	369664	24.6577	1910.1	290333
569	323761	23.8537	1787.6	254281	609	370881	24.6779	1913.2	291289
570	324900	23.8747	1790.7	255176	610	372100	24.6982	1916.4	292247
571	326041	23.8956	1793.8	256072	611	373321	24.7184	1919.5	293206
572	327184	23.9165	1797.0	256970	612	374544	24.7386	1922.7	294166
573	328329	23.9374	1800.1	257869	613	375769	24.7588	1925.8	295128
574	329476	23.9583	1803.3	258770	614	376996	24.7790	1928.9	296092
575	330625	23.9792	1806.4	259672	615	378225	24.7992	1932.1	297057
576	331776	24.0000	1809.6	260576	616	379456	24.8193	1935.2	298024
577	332929	24.0208	1812.7	261482	617	380689	24.8395	1938.4	298992
578	334084	24.0416	1815.8	262389	618	381924	24.8596	1941.5	299962
579	335241	24.0624	1819.0	263298	619	383161	24.8797	1944.6	300934
580	336400	24.0832	1822.1	264208	620	384400	24.8998	1947.8	301907
581	337561	24.1039	1825.3	265120	621	385641	24.9199	1950.9	302882
582	338724	24.1247	1828.4	266033	622	386884	24.9399	1954.1	303858
583	339889	24.1454	1831.6	266948	623	388129	24.9600	1957.2	304836
584	341056	24.1661	1834.7	267865	624	389376	24.9800	1960.4	305815
585	342225	24.1868	1837.8	268783	625	390625	25.0000	1963.5	306796
586	343396	24.2074	1841.0	269703	626	391876	25.0200	1966.6	307779
587	344569	24.2281	1844.1	270624	627	393129	25.0400	1969.8	308763
588	345744	24.2487	1847.3	271547	628	394384	25.0599	1972.9	309748
589	346921	24.2693	1850.4	272471	629	395641	25.0799	1976.1	310736
590	348100	24.2899	1853.5	273397	630	396900	25.0998	1979.2	311725
591	349281	24.3105	1856.7	274325	631	398161	25.1197	1982.3	312715
592	350464	24.3311	1859.8	275254	632	399424	25.1396	1985.5	313707
593	351649	24.3516	1863.0	276184	633	400689	25.1595	1988.6	314700
594	352836	24.3721	1866.1	277117	634	401956	25.1794	1991.8	315696
595	354025	24.3926	1869.2	278051	635	403225	25.1992	1994.9	316692
596	355216	24.4131	1872.4	278986	636	404496	25.2190	1998.1	317690
597	356409	24.4336	1875.5	279923	637	405769	25.2389	2001.2	318690
598	357604	24.4540	1878.7	280862	638	407044	25.2587	2004.3	319692
599	358801	24.4745	1881.8	281802	639	408321	25.2784	2007.5	320695
600	360000	24.4949	1885.0	282743	640	409600	25.2982	2010.6	321699

SQUARES, SQUARE ROOTS, CIRCUMFERENCES AND CIRCULAR AREAS OF NUMBERS FROM 1 TO 1000

No.	Square	Square Root	No. = Dia.		No.	Square	Square Root	No. = Dia.	
			Circum.	Area				Circum.	Area
641	410881	25.3180	2013.8	322705	681	463761	26.0960	2139.4	364237
642	412164	25.3377	2016.9	323713	682	465124	26.1151	2142.6	365308
643	413449	25.3574	2020.0	324722	683	466489	26.1343	2145.7	366380
644	414736	25.3772	2023.2	325733	684	467856	26.1534	2148.8	367453
645	416025	25.3969	2026.3	326745	685	469225	26.1725	2152.0	368528
646	417316	25.4165	2029.5	327759	686	470596	26.1916	2155.1	369605
647	418609	25.4362	2032.6	328775	687	471969	26.2107	2158.3	370684
648	419904	25.4558	2035.8	329792	688	473344	26.2298	2161.4	371764
649	421201	25.4755	2038.9	330810	689	474721	26.2488	2164.6	372845
650	422500	25.4951	2042.0	331831	690	476100	26.2679	2167.7	373928
651	423801	25.5147	2045.2	332853	691	477481	26.2869	2170.8	375013
652	425104	25.5343	2048.3	333876	692	478864	26.3059	2174.0	376099
653	426409	25.5539	2051.5	334901	693	480249	26.3249	2177.1	377187
654	427716	25.5734	2054.6	335927	694	481636	26.3439	2180.3	378276
655	429025	25.5930	2057.7	336955	695	483025	26.3629	2183.4	379367
656	430336	25.6125	2060.9	337985	696	484416	26.3818	2186.5	380459
657	431649	25.6320	2064.0	339016	697	485809	26.4008	2189.7	381553
658	432964	25.6515	2067.2	340049	698	487204	26.4197	2192.8	382649
659	434281	25.6710	2070.3	341084	699	488601	26.4386	2196.0	383746
660	435600	25.6905	2073.5	342119	700	490000	26.4575	2199.1	384845
661	436921	25.7099	2076.6	343157	701	491401	26.4764	2202.3	385945
662	438244	25.7294	2079.7	344196	702	492804	26.4953	2205.4	387047
663	439569	25.7488	2082.9	345237	703	494209	26.5141	2208.5	388151
664	440896	25.7682	2086.0	346279	704	495616	26.5330	2211.7	389256
665	442225	25.7876	2089.2	347323	705	497025	26.5518	2214.8	390363
666	443556	25.8070	2092.3	348368	706	498436	26.5707	2218.0	391471
667	444889	25.8263	2095.4	349415	707	499849	26.5895	2221.1	392580
668	446224	25.8457	2098.6	350464	708	501264	26.6083	2224.2	393692
669	447561	25.8650	2101.7	351514	709	502681	26.6271	2227.4	394805
670	448900	25.8844	2104.9	352565	710	504100	26.6458	2230.5	395919
671	450241	25.9037	2108.0	353618	711	505521	26.6646	2233.7	397035
672	451584	25.9230	2111.2	354673	712	506944	26.6833	2236.8	398153
673	452929	25.9422	2114.3	355730	713	508369	26.7021	2240.0	399272
674	454276	25.9615	2117.4	356788	714	509796	26.7208	2243.1	400393
675	455625	25.9808	2120.6	357847	715	511225	26.7395	2246.2	401515
676	456976	26.0000	2123.7	358908	716	512656	26.7582	2249.4	402639
677	458329	26.0192	2126.9	359971	717	514089	26.7769	2252.5	403765
678	459684	26.0384	2130.0	361035	718	515524	26.7955	2255.7	404892
679	461041	26.0576	2133.1	362101	719	516961	26.8142	2258.8	406020
680	462400	26.0768	2136.3	363168	720	518400	26.8328	2261.9	407150

**SQUARES, SQUARE ROOTS,
CIRCUMFERENCES AND CIRCULAR
AREAS OF NUMBERS FROM 1 TO 1000**

No.	Square	Square Root	No. = Dia.		No.	Square	Square Root	No. = Dia.	
			Circum.	Area				Circum.	Area
721	519841	26.8514	2265.1	408282	761	579121	27.5862	2390.8	454841
722	521284	26.8701	2268.2	409415	762	580644	27.6043	2393.9	456037
723	522729	26.8887	2271.4	410550	763	582169	27.6225	2397.0	457234
724	524176	26.9072	2274.5	411687	764	583696	27.6405	2400.2	458434
725	525625	26.9258	2277.7	412825	765	585225	27.6586	2403.3	459635
726	527076	26.9444	2280.8	413965	766	586756	27.6767	2406.5	460837
727	528529	26.9629	2283.9	415106	767	588289	27.6948	2409.6	462041
728	529984	26.9815	2287.1	416248	768	589824	27.7128	2412.7	463247
729	531441	27.0000	2290.2	417393	769	591361	27.7308	2415.9	464454
730	532900	27.0185	2293.4	418539	770	592900	27.7489	2419.0	465663
731	534361	27.0370	2296.5	419686	771	594441	27.7669	2422.2	466873
732	535824	27.0555	2299.6	420835	772	595984	27.7849	2425.3	468085
733	537289	27.0740	2302.8	421986	773	597529	27.8029	2428.5	469298
734	538756	27.0924	2305.9	423138	774	599076	27.8209	2431.6	470513
735	540225	27.1109	2309.1	424293	775	600625	27.8388	2434.7	471730
736	541696	27.1293	2312.2	425447	776	602176	27.8568	2437.9	472948
737	543169	27.1477	2315.4	426604	777	603729	27.8747	2441.0	474168
738	544644	27.1662	2318.5	427762	778	605284	27.8927	2444.2	475389
739	546121	27.1846	2321.6	428922	779	606841	27.9106	2447.3	476612
740	547600	27.2029	2324.8	430084	780	608400	27.9285	2450.4	477836
741	549081	27.2213	2327.9	431247	781	609961	27.9464	2453.6	479062
742	550564	27.2397	2331.1	432412	782	611524	27.9643	2456.7	480290
743	552049	27.2580	2334.2	433578	783	613089	27.9821	2459.9	481519
744	553536	27.2764	2337.3	434746	784	614656	28.0000	2463.0	482750
745	555025	27.2947	2340.5	435916	785	616225	28.0179	2466.2	483982
746	556516	27.3130	2343.6	437087	786	617796	28.0357	2469.3	485216
747	558009	27.3313	2346.8	438259	787	619369	28.0535	2472.4	486451
748	559504	27.3496	2349.9	439433	788	620944	28.0713	2475.6	487688
749	561001	27.3679	2353.1	440609	789	622521	28.0891	2478.7	488927
750	562500	27.3861	2356.2	441786	790	624100	28.1069	2481.9	490167
751	564001	27.4044	2359.3	442965	791	625681	28.1247	2485.0	491409
752	565504	27.4226	2362.5	444146	792	627264	28.1425	2488.1	492652
753	567009	27.4408	2365.6	445328	793	628849	28.1603	2491.3	493897
754	568516	27.4591	2368.8	446511	794	630436	28.1780	2494.4	495143
755	570025	27.4773	2371.9	447697	795	632025	28.1957	2497.6	496391
756	571536	27.4955	2375.0	448883	796	633616	28.2135	2500.7	497641
757	573049	27.5136	2378.2	450072	797	635209	28.2312	2503.8	498892
758	574564	27.5318	2381.3	451262	798	636804	28.2489	2507.0	500145
759	576081	27.5500	2384.5	452453	799	638401	28.2666	2510.1	501399
760	577600	27.5681	2387.6	453646	800	640000	28.2843	2513.3	502655

SQUARES, SQUARE ROOTS, CIRCUMFERENCES AND CIRCULAR AREAS OF NUMBERS FROM 1 TO 1000

No.	Square	Square Root	No. = Dia.		No.	Square	Square Root	No. = Dia.	
			Circum.	Area				Circum.	Area
801	641601	28.3019	2516.4	503912	841	707281	29.0000	2642.1	555497
802	643204	28.3196	2519.6	505171	842	708964	29.0172	2645.2	556819
803	644809	28.3373	2522.7	506432	843	710649	29.0345	2648.4	558142
804	646416	28.3549	2525.8	507694	844	712336	29.0517	2651.5	559467
805	648025	28.3725	2529.0	508958	845	714025	29.0689	2654.6	560794
806	649636	28.3901	2532.1	510223	846	715716	29.0861	2657.8	562122
807	651249	28.4077	2535.3	511490	847	717409	29.1033	2660.9	563452
808	652864	28.4253	2538.4	512758	848	719104	29.1204	2664.1	564783
809	654481	28.4429	2541.5	514028	849	720801	29.1376	2667.2	566116
810	656100	28.4605	2544.7	515300	850	722500	29.1548	2670.4	567450
811	657721	28.4781	2547.8	516573	851	724201	29.1719	2673.5	568786
812	659344	28.4956	2551.0	517848	852	725904	29.1890	2676.6	570124
813	660969	28.5132	2554.1	519124	853	727609	29.2062	2679.8	571463
814	662596	28.5307	2557.3	520402	854	729316	29.2233	2682.9	572803
815	664225	28.5482	2560.4	521681	855	731025	29.2404	2686.1	574146
816	665856	28.5657	2563.5	522962	856	732736	29.2575	2689.2	575490
817	667489	28.5832	2566.7	524245	857	734449	29.2746	2692.3	576835
818	669124	28.6007	2569.8	525529	858	736164	29.2916	2695.5	578182
819	670761	28.6182	2573.0	526814	859	737881	29.3087	2698.6	579530
820	672400	28.6356	2576.1	528102	860	739600	29.3258	2701.8	580880
821	674041	28.6531	2579.2	529391	861	741321	29.3428	2704.9	582232
822	675684	28.6705	2582.4	530681	862	743044	29.3598	2708.1	583585
823	677329	28.6880	2585.5	531973	863	744769	29.3769	2711.2	584940
824	678976	28.7054	2588.7	533267	864	746496	29.3939	2714.3	586297
825	680625	28.7228	2591.8	534562	865	748225	29.4109	2717.5	587655
826	682276	28.7402	2595.0	535858	866	749956	29.4279	2720.6	589014
827	683929	28.7576	2598.1	537157	867	751689	29.4449	2723.8	590375
828	685584	28.7750	2601.2	538456	868	753424	29.4618	2726.9	591738
829	687241	28.7924	2604.4	539758	869	755161	29.4788	2730.0	593102
830	688900	28.8097	2607.5	541061	870	756900	29.4958	2733.2	594468
831	690561	28.8271	2610.7	542365	871	758641	29.5127	2736.3	595835
832	692224	28.8444	2613.8	543671	872	760384	29.5296	2739.5	597204
833	693889	28.8617	2616.9	544979	873	762129	29.5466	2742.6	598575
834	695556	28.8791	2620.1	546288	874	763876	29.5635	2745.8	599947
835	697225	28.8964	2623.2	547599	875	765625	29.5804	2748.9	601320
836	698896	28.9137	2626.4	548912	876	767376	29.5973	2752.0	602696
837	700569	28.9310	2629.5	550226	877	769129	29.6142	2755.2	604073
838	702244	28.9482	2632.7	551541	878	770884	29.6311	2758.3	605451
839	703921	28.9655	2635.8	552858	879	772641	29.6479	2761.5	606831
840	705600	28.9828	2638.9	554177	880	774400	29.6648	2764.6	608212

SQUARES, SQUARE ROOTS, CIRCUMFERENCES AND CIRCULAR AREAS OF NUMBERS FROM 1 TO 1000

No.	Square	Square Root	No. = Dia.		No.	Square	Square Root	No. = Dia.	
			Circum.	Area				Circum.	Area
881	776161	29.6816	2767.7	609595	921	848241	30.3480	2893.4	666207
882	777924	29.6985	2770.9	610980	922	850084	30.3645	2896.5	667654
883	779689	29.7153	2774.0	612366	923	851929	30.3809	2899.7	669103
884	781456	29.7321	2777.2	613754	924	853776	30.3974	2902.8	670554
885	783225	29.7489	2780.3	615143	925	855625	30.4138	2906.0	672006
886	784996	29.7658	2783.5	616534	926	857476	30.4302	2909.1	673460
887	786769	29.7825	2786.6	617927	927	859329	30.4467	2912.3	674915
888	788544	29.7993	2789.7	619321	928	861184	30.4631	2915.4	676372
889	790321	29.8161	2792.9	620717	929	863041	30.4795	2918.5	677831
890	792100	29.8329	2796.0	622114	930	864900	30.4959	2921.7	679291
891	793881	29.8496	2799.2	623513	931	866761	30.5123	2924.8	680752
892	795664	29.8664	2802.3	624913	932	868624	30.5287	2928.0	682216
893	797449	29.8831	2805.4	626315	933	870489	30.5450	2931.1	683680
894	799236	29.8998	2808.6	627718	934	872356	30.5614	2934.2	685147
895	801025	29.9166	2811.7	629124	935	874225	30.5778	2937.4	686615
896	802816	29.9333	2814.9	630530	936	876096	30.5941	2940.5	688084
897	804609	29.9500	2818.0	631938	937	877969	30.6105	2943.7	689555
898	806404	29.9666	2821.2	633348	938	879844	30.6268	2946.8	691028
899	808201	29.9833	2824.3	634760	939	881721	30.6431	2950.0	692502
900	810000	30.0000	2827.4	636173	940	883600	30.6594	2953.1	693978
901	811801	30.0167	2830.6	637587	941	885481	30.6757	2956.2	695455
902	813604	30.0333	2833.7	639003	942	887364	30.6920	2959.4	696934
903	815409	30.0500	2836.9	640421	943	889249	30.7083	2962.5	698415
904	817216	30.0666	2840.0	641840	944	891136	30.7246	2965.7	699897
905	819025	30.0832	2843.1	643261	945	893025	30.7409	2968.8	701380
906	820836	30.0998	2846.3	644683	946	894916	30.7571	2971.9	702865
907	822649	30.1164	2849.4	646107	947	896809	30.7734	2975.1	704352
908	824464	30.1330	2852.6	647533	948	898704	30.7896	2978.2	705840
909	826281	30.1496	2855.7	648960	949	900601	30.8058	2981.4	707330
910	828100	30.1662	2858.8	650388	950	902500	30.8221	2984.5	708822
911	829921	30.1828	2862.0	651818	951	904401	30.8383	2987.7	710315
912	831744	30.1993	2865.1	653250	952	906304	30.8545	2990.8	711809
913	833569	30.2159	2868.3	654684	953	908209	30.8707	2993.9	713306
914	835396	30.2324	2871.4	656118	954	910116	30.8869	2997.1	714803
915	837225	30.2490	2874.6	657555	955	912025	30.9031	3000.2	716303
916	839056	30.2655	2877.7	658993	956	913936	30.9192	3003.4	717804
917	840889	30.2820	2880.8	660433	957	915849	30.9354	3006.5	719306
918	842724	30.2985	2884.0	661874	958	917764	30.9516	3009.6	720810
919	844561	30.3150	2887.1	663317	959	919681	30.9677	3012.8	722316
920	846400	30.3315	2890.3	664761	960	921600	30.9839	3015.9	723823

SQUARES, SQUARE ROOTS, CIRCUMFERENCES AND CIRCULAR AREAS OF NUMBERS FROM 1 TO 1000

No.	Square	Square Root	No. = Dia.		No.	Square	Square Root	No. = Dia.	
			Circum.	Area				Circum.	Area
961	923521	31.0000	3019.1	725332	981	962361	31.3209	3081.9	755837
962	925444	31.0161	3022.2	726842	982	964324	31.3369	3085.0	757378
963	927369	31.0322	3025.4	728354	983	966289	31.3528	3088.2	758922
964	929296	31.0483	3028.5	729867	984	968256	31.3688	3091.3	760466
965	931225	31.0644	3031.6	731382	985	970225	31.3847	3094.5	762013
966	933156	31.0805	3034.8	732899	986	972196	31.4006	3097.6	763561
967	935089	31.0966	3037.9	734417	987	974169	31.4166	3100.8	765111
968	937024	31.1127	3041.1	735937	988	976144	31.4325	3103.9	766662
969	938961	31.1288	3044.2	737458	989	978121	31.4484	3107.0	768214
970	940900	31.1448	3047.3	738981	990	980100	31.4643	3110.2	769769
971	942841	31.1609	3050.5	740506	991	982081	31.4802	3113.3	771325
972	944784	31.1769	3053.6	742032	992	984064	31.4960	3116.5	772882
973	946729	31.1929	3056.8	743559	993	986049	31.5119	3119.6	774441
974	948676	31.2090	3059.9	745088	994	988036	31.5278	3122.7	776002
975	950625	31.2250	3063.1	746619	995	990025	31.5436	3125.9	777564
976	952576	31.2410	3066.2	748151	996	992016	31.5595	3129.0	779128
977	954529	31.2570	3069.3	749685	997	994009	31.5753	3132.2	780693
978	956484	31.2730	3072.5	751221	998	996004	31.5911	3135.3	782260
979	958441	31.2890	3075.6	752758	999	998001	31.6070	3138.5	783828
980	960400	31.3050	3078.8	754296					

**USEFUL INFORMATION
FOR DESIGNERS**

**THE INFORMATION FOR DESIGNERS ON
THE FOLLOWING PAGES WAS SELECTED
FROM DATA IN THE OFFICE OF THE
PHOENIX BRIDGE COMPANY**

COOPER'S LOADING

WHEEL WHICH GIVES MAXIMUM CONCENTRATION FOR TWO SPANS,
OR MAXIMUM MOMENT AT A GIVEN POINT OF A SPAN

E-60 LOADING ONE RAIL

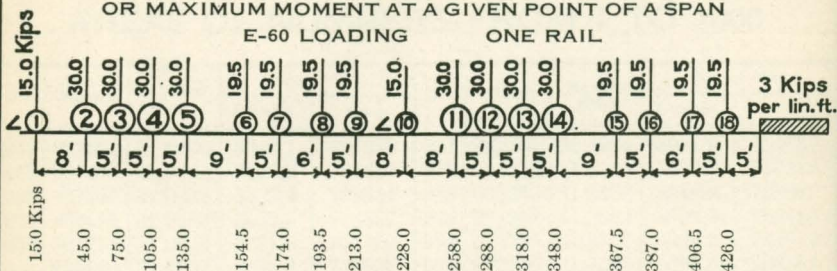

15.0 Kips

Span Length	10	15	20	25	30	35	40	45	50	55	60	65	70	80	90	100	110	120	130	140	
300-290																					
280-270-260	2	3	3	4	4	5	5	6	7	7	8	9	10	11	12	13	14	15	17	18	
250-240-230																					
220-210-200	2	3	3	4	4	5	5	6	7	8	8	9	10	11	12	13	14	15	17	18	
190-180																					
170-160-150	2	3	3	4	4	5	5	6	7	8	9	9	11	12	12	13	14	15	17	18	
	140	3	3	3	4	4	5	5	6	7	8	9	10	11	12	12	13	14	15	17	18
	130	3	3	3	4	4	5	5	6	7	8	9	10	11	12	12	13	14	15	17	
	120	3	3	3	4	4	5	6	6	7	8	9	10	11	12	13	13	14	15		
	110	3	3	3	4	4	5	6	7	7	8	9	10	11	12	13	13	14			
	100	3	3	3	4	5	5	14	14	14	14	13	13	11	12	13	13				
	90	3	3	4	4	5	13	13	13	13	13	13	13	12	13						
	80	3	3	4	4	13	13	13	12	12	12	12	12	12							
	70	3	3	4	4	13	13	12	12	12	12	11	11	11							
	65	3	3	4	4	12	12	12	12	12	11	11	11								
	60	3	3	4	4	13	13	12	11	11	11	11									
	55	12	12	12	4	12	13	12	12	12	11										
	50	12	12	12	12	12	13	13	13	12											
	45	12	12	12	12	12	13	13	13												
	40	3	3	3	12	12	13	13													
	35	3	3	4	4	13	13														
	30	3	3	4	4	13															
	25	3	3	4	4																
	20	4	3	4																	
	15	3	3																		
	10	3																			

The shorter span or span segment is ahead except
where the wheel is overlined.

COOPER'S E-60 LOADING—ONE RAIL

MOMENTS IN FOOT-KIPS

A	Wheel	Load	Moment	A	Wheel	Load	Moment
0	1	15.0	0				
1			15	51			5883
2			30	52			6096
3			45	53			6309
4			60	54			6522
5			75	55			6735
6			90				
7			105	56	10	228.0	6948
				57			7176
8	2	45.0	120	58			7404
9			165	59			7632
10			210	60			7860
11			255	61			8088
12			300	62			8316
				63			8544
13	3	75.0	345				
14			420	64	11	258.0	8772
15			495	65			9030
16			570	66			9288
17			645	67			9546
				68			9804
18	4	105.0	720				
19			825	69	12	288.0	10062
20			930	70			10350
21			1035	71			10638
22			1140	72			10926
				73			11214
23	5	135.0	1245				
24			1380	74	13	318.0	11502
25			1515	75			11820
26			1650	76			12138
27			1785	77			12456
28			1920	78			12774
29			2055				
30			2190	79	14	348.0	13092
31			2325	80			13440
				81			13788
32	6	154.5	2460	82			14136
33			2614.5	83			14484
34			2769	84			14832
35			2923.5	85			15180
36			3078	86			15528
				87			15876
37	7	174.0	3232.5				
38			3406.5	88	15	367.5	16224
39			3580.5	89			16591.5
40			3754.5	90			16959
41			3928.5	91			17326.5
42			4102.5	92			17694
43	8	193.5	4276.5	93	16	387.0	18061.5
44			4470	94			18448.5
45			4663.5	95			18835.5
46			4857	96			19222.5
47			5050.5	97			19609.5
				98			19996.5
48	9	213.0	5244				
49			5457	99	17	406.5	20383.5
50			5670	100			20790

"A" is the distance from the first pilot wheel to the point about which the static moment is given.

COOPER'S E-60 LOADING—ONE RAIL

MOMENTS IN FOOT-KIPS

A	Wheel	Load	Moment	A	—	Load	Moment
101			21196.5				
102			21603	151	42	552	45084
103			22009.5	152	43	555	45637.5
104	18	426	22416	153	44	558	46194
105			22842	154	45	561	46753.5
106			23268	155	46	564	47316
107			23694	156	47	567	47881.5
108			24120	157	48	570	48450
109			24546	158	49	573	49021.5
A		Load	Moment	159	50	576	49596
110	1	429	24973.5	160	51	579	50173.5
111	2	432	25404	161	52	582	50754
112	3	435	25837.5	162	53	585	51337.5
113	4	438	26274	163	54	588	51924
114	5	441	26713.5	164	55	591	52513.5
115	6	444	27156	165	56	594	53106
116	7	447	27601.5	166	57	597	53701.5
117	8	450	28050	167	58	600	54300
118	9	453	28501.5	168	59	603	54901.5
119	10	456	28956	169	60	606	55506
120	11	459	29413.5	170	61	609	56113.5
121	12	462	29874	171	62	612	56724
122	13	465	30337.5	172	63	615	57337.5
123	14	468	30804	173	64	618	57954
124	15	471	31273.5	174	65	621	58573.5
125	16	474	31746	175	66	624	59196
126	17	477	32221.5	176	67	627	59821.5
127	18	480	32700	177	68	630	60450
128	19	483	33181.5	178	69	633	61081.5
129	20	486	33666	179	70	636	61716
130	21	489	34153.5	180	71	639	62353.5
131	22	492	34644	181	72	642	62994
132	23	495	35137.5	182	73	645	63637.5
133	24	498	35634	183	74	648	64284
134	25	501	36133.5	184	75	651	64933.5
135	26	504	36636	185	76	654	65586
136	27	507	37141.5	186	77	657	66241.5
137	28	510	37650	187	78	660	66900
138	29	513	38161.5	188	79	663	67561.5
139	30	516	38676	189	80	666	68226
140	31	519	39193.5	190	81	669	68893.5
141	32	522	39714	191	82	672	69564
142	33	525	40237.5	192	83	675	70237.5
143	34	528	40764	193	84	678	70914
144	35	531	41293.5	194	85	681	71593.5
145	36	534	41826	195	86	684	72276
146	37	537	42361.5	196	87	687	72961.5
147	38	540	42900	197	88	690	73650
148	39	543	43441.5	198	89	693	74341.5
149	40	546	43986	199	90	696	75036
150	41	549	44533.5	200	91	699	75733.5

Length of Uniform Load

COOPER'S E-60 LOADING—ONE RAIL

MOMENTS IN FOOT-KIPS

A		Load	Moment	A		Load	Moment
201	92	702	76434	251	142	852	115284
202	93	705	77137.5	252	143	855	116137.5
203	94	708	77844	253	144	858	116994
204	95	711	78553.5	254	145	861	117853.5
205	96	714	79266	255	146	864	118716
206	97	717	79981.5	256	147	867	119581.5
207	98	720	80700	257	148	870	120450
208	99	723	81421.5	258	149	873	121321.5
209	100	726	82146	259	150	876	122196
210	101	729	82873.5	260	151	879	123073.5
211	102	732	83604	261	152	882	123954
212	103	735	84337.5	262	153	885	124837.5
213	104	738	85074	263	154	888	125724
214	105	741	85813.5	264	155	891	126613.5
215	106	744	86556	265	156	894	127506
216	107	747	87301.5	266	157	897	128401.5
217	108	750	88050	267	158	900	129309
218	109	753	88801.5	268	159	903	130201.5
219	110	756	89556	269	160	906	131106
220	111	759	90313.5	270	161	909	132013.5
221	112	762	91074	271	162	912	132924
222	113	765	91837.5	272	163	915	133837.5
223	114	768	92604	273	164	918	134754
224	115	771	93373.5	274	165	921	135673.5
225	116	774	94146	275	166	924	136596
226	117	777	94921.5	276	167	927	137521.5
227	118	780	95700	277	168	930	138450
228	119	783	96481.5	278	169	933	139381.5
229	120	786	97266	279	170	936	140316
230	121	789	98053.5	280	171	939	141253.5
231	122	792	98844	281	172	942	142194
232	123	795	99637.5	282	173	945	143137.5
233	124	798	100434	283	174	948	144084
234	125	801	101233.5	284	175	951	145033.5
235	126	804	102036	285	176	954	145986
236	127	807	102841.5	286	177	957	146941.5
237	128	810	103650	287	178	960	147900
238	129	813	104461.5	288	179	963	148861.5
239	130	816	105276	289	180	966	149826
240	131	819	106093.5	290	181	969	150793.5
241	132	822	106914	291	182	972	151764
242	133	825	107737.5	292	183	975	152737.5
243	134	828	108564	293	184	978	153714
244	135	831	109393.5	294	185	981	154693.5
245	136	834	110226	295	186	984	155676
246	137	837	111061.5	296	187	987	156661.5
247	138	840	111900	297	188	990	157650
248	139	843	112741.5	298	189	993	158641.5
249	140	846	113586	299	190	996	159636
250	141	849	114433.5	300	191	999	160633.5

ABSOLUTE MAXIMUM BENDING MOMENTS

E-60 LOADING

Positions of Loads	Span Limits	Bending Moments for One Rail
	8.5 to 11.1	$15,000 L + \frac{93,750}{L} - 75,000$
	11.1 to 18.7	$22,500 L - 15,000$
	18.7 to 27.6	$30,000 L + \frac{187,500}{L} - 300,000$
	27.6 to 35.0	$33,750 L + \frac{20,417}{L} - 450,000$
	35.0 to 38.7	$38,625 L + \frac{142,733}{L} - 571,500$
	38.7 to 48.3	$43,500 L + \frac{7,762}{L} - 756,750$
	48.3 to 53.5	$48,375 L + \frac{406,616}{L} - 1,000,500$
	53.5 to 58.5	$53,250 L + \frac{3,423}{L} - 1,254,000$
	58.5 to 63.4	$58,125 L + \frac{439,055}{L} - 1,546,500$
	63.4 to 69.9	$63,000 L + \frac{1,181}{L} - 2,004,000$

Spans Wheels on Span Equations for Length "X" of Uniform Load on Span

70 to 73		8 to 18	$X = \frac{\sqrt{C^2 + 0.6 [8.4(L - 35) - 292.85]} - C}{0.3}$	$X = 0.08 \text{ to } 1.99$ $C = 16.8 - 0.1(L - 35)$
74 to 82		7 to 18	$X = \frac{\sqrt{C^2 + 0.6 [9.05(L - 35) - 339.65]} - C}{0.3}$	$X = 0.93 \text{ to } 5.99$ $C = 18.1 - 0.1(L - 35)$
83 to 99		6 to 18	$X = \frac{\sqrt{C^2 + 0.6 [9.7(L - 35) - 389.70]} - C}{0.3}$	$X = 4.95 \text{ to } 15.13$ $C = 19.4 - 0.1(L - 35)$
100 to 107		4 to 18	$X = \frac{\sqrt{C^2 + 0.6 [11.7(L - 40) - 566.70]} - C}{0.3}$	$X = 7.31 \text{ to } 11.77$ $C = 23.4 - 0.1(L - 40)$
108 to 120		2 to 18	$X = \frac{\sqrt{C^2 + 0.6 [13.7(L - 45) - 763.70]} - C}{0.3}$	$X = 4.56 \text{ to } 12.14$ $C = 27.4 - 0.1(L - 45)$
121 to 129 and over		1 to 18	$X = \frac{\sqrt{C^2 + 0.6 [14.2(L - 45) - 818.20]} - C}{0.3}$	$X = 11.58 \text{ to } 16.65$ $C = 28.4 - 0.1(L - 45)$

EQUIVALENT UNIFORM LOADS

COOPER'S E-60 LOADING—ONE RAIL

Span	End	.1 Point	.2 Point	.3 Point	.4 Point	Center
30'	6302	5928	5544	5600	5504	5467
40'	5655	5292	5060	5024	4938	4914
50'	5233	4901	4766	4675	4594	4541
60'	4900	4580	4476	4436	4372	4316
70'	4735	4340	4276	4196	4180	4183
80'	4658	4308	4190	4062	4062	4050
90'	4573	4261	4152	4024	3965	3955
100'	4500	4214	4099	4008	3943	3864
110'	4418	4161	4062	4002	3938	3827
120'	4342	4098	4012	3954	3916	3830
130'	4272	4037	3954	3882	3877	3816
140'	4206	3994	3897	3800	3820	3794
150'	4147	3948	3840	3742	3769	3763
160'	4092	3906	3785	3707	3709	3730
170'	4042	3864	3752	3668	3665	3686
180'	3996	3823	3709	3638	3643	3643
190'	3954	3785	3668	3606	3615	3601
200'	3916	3748	3630	3577	3589	3558
250'	3758	3605	3499	3475	3446	3371
300'	3647	3497	3408	3389	3319	3256
350'	3563	3416	3343	3308	3234	3188
400'	3499	3353	3301	3240	3180	3144
450'	3448	3304	3262	3190	3142	3114
500'	3406	3268	3223	3154	3115	3092

EQUIVALENT UNIFORM LOADS
COOPER'S E-60 ONE RAIL

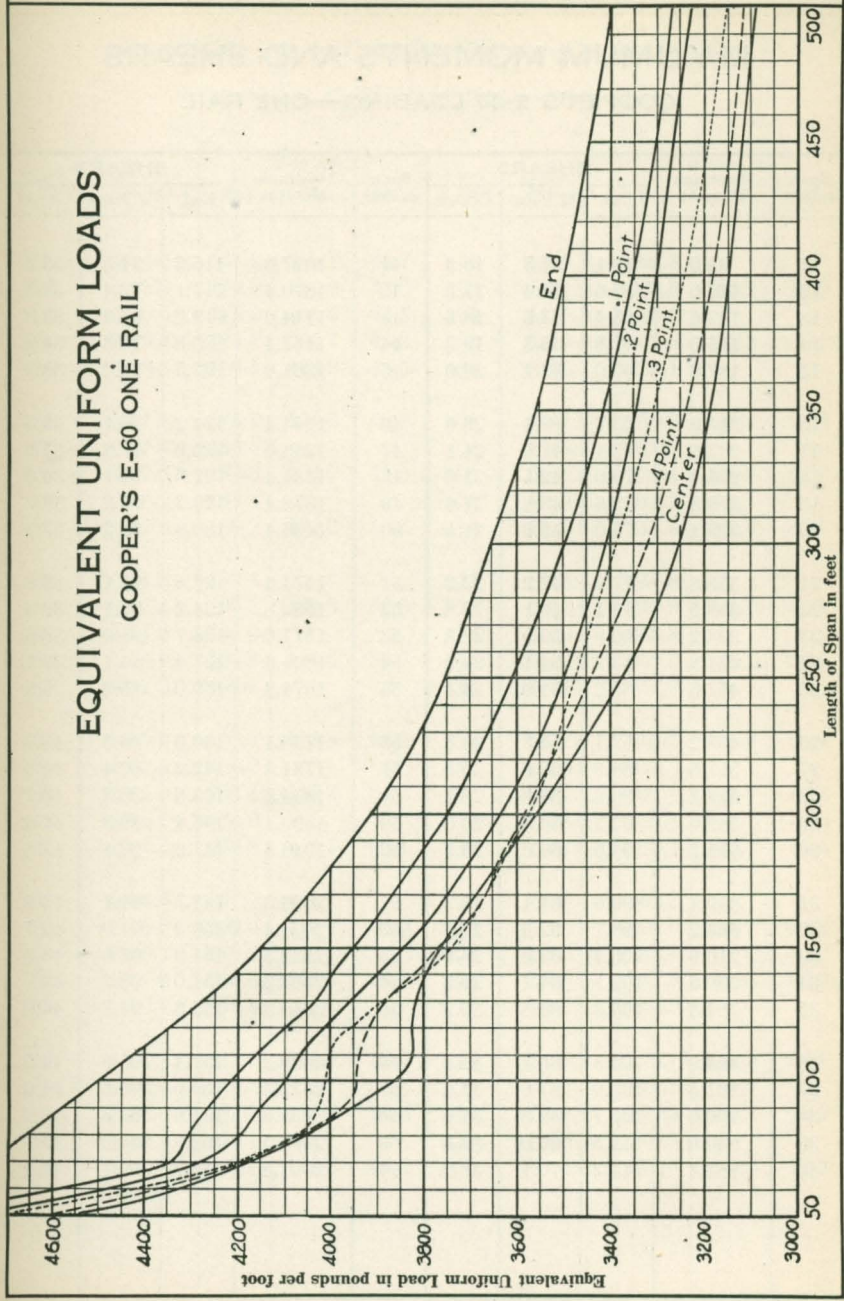

MAXIMUM MOMENTS AND SHEARS

COOPER'S E-60 LOADING—ONE RAIL

Span in Feet	Maximum Moment	SHEARS			Span in Feet	Maximum Moment	SHEARS		
		End	¼ Point	Center			End	¼ Point	Center
11	98.5	49.1	31.3	16.3	41	1027.0	115.2	71.3	33.5
12	120.0	52.6	32.4	17.5	42	1070.4	117.1	72.4	33.8
13	142.6	55.4	33.5	18.5	43	1114.0	119.0	73.3	34.3
14	165.0	57.8	35.3	19.3	44	1157.4	120.8	74.3	34.8
15	187.6	60.0	37.4	20.0	45	1201.0	122.5	75.2	35.2
16	210.0	63.7	39.4	20.6	46	1244.4	124.2	76.1	35.5
17	232.6	67.1	41.0	21.1	47	1288.0	125.9	77.2	35.9
18	255.0	70.0	42.5	21.6	48	1331.4	127.6	78.1	36.2
19	279.8	72.6	43.8	21.6	49	1378.4	129.2	79.2	36.7
20	309.4	75.0	45.0	21.5	50	1426.4	130.8	80.2	37.3
21	338.9	77.2	47.2	22.2	51	1474.6	132.5	81.1	37.8
22	368.5	79.1	49.1	22.8	52	1522.8	134.2	82.1	38.3
23	398.2	80.9	50.9	23.3	53	1571.0	135.7	83.0	38.6
24	427.8	83.2	52.4	23.9	54	1621.6	137.4	84.1	39.1
25	457.6	85.2	54.0	24.4	55	1674.8	139.0	85.2	39.6
26	487.2	87.1	55.3	24.8	56	1728.1	140.6	86.3	40.0
27	517.0	88.9	56.6	25.3	57	1781.3	142.2	87.4	40.3
28	548.3	90.6	58.0	25.7	58	1834.6	143.8	88.3	40.7
29	582.0	92.3	58.8	26.0	59	1890.4	145.4	89.3	41.3
30	615.7	94.6	60.0	26.5	60	1948.3	147.0	90.1	41.8
31	649.4	96.6	61.1	27.2	61	2006.3	148.7	91.1	42.2
32	683.2	98.7	62.3	28.1	62	2064.4	150.2	91.9	42.7
33	716.9	100.4	63.5	28.9	63	2122.3	151.9	92.9	43.2
34	750.6	102.1	64.7	29.5	64	2183.3	154.0	93.7	43.7
35	784.4	103.8	65.8	30.2	65	2246.3	155.8	94.7	44.0
36	823.0	105.8	66.7	30.8	66	2309.3	157.4	95.5	44.5
37	861.5	107.9	67.6	31.4	67	2372.3	159.6	96.5	44.9
38	900.0	109.7	68.3	31.9	68	2435.3	161.6	97.3	45.4
39	940.0	111.5	69.0	32.5	69	2498.3	162.8	98.3	45.7
40	983.4	113.2	70.1	33.0	70	2561.3	165.7	99.1	46.1

MAXIMUM MOMENTS AND SHEARS

COOPER'S E-60 LOADING—ONE RAIL

Span in Feet	Maximum Moment	SHEARS			Span in Feet	Maximum Moment	SHEARS		
		End	¼ Point	Center			End	¼ Point	Center
71	2624.5	167.8	100.1	46.7	101	4928.4	226.8		
72	2688.2	170.0	100.9	47.0	102	5021.8	228.6	132.1	59.9
73	2752.6	172.2	101.9	47.5	103	5116.3	230.5		
74	2819.8	174.4	102.7	48.0	104	5212.8	232.3	134.3	60.7
75	2888.3	176.5	103.6	48.5	105	5306.4	234.1		
76	2957.6	178.8	104.5	49.0	106	5401.2	235.9	136.4	61.4
77	3027.4	180.6			107	5498.4	237.7		
78	3097.6	182.5	106.2	49.8	108	5616.0	239.4	138.6	62.3
79	3168.2	184.4			109	5722.8	241.2		
80	3239.4	186.2	108.0	50.5	110	5829.6	243.0	140.9	63.1
81	3311.2	188.4			111	5936.4	244.8		
82	3383.4	190.3	109.8	51.6	112	6042.0	246.6	143.0	63.8
83	3461.0	192.2			113	6150.0	248.3		
84	3534.6	194.3	111.6	52.6	114	6259.2	250.0	145.1	64.7
85	3611.8	196.1			115	6367.2	251.8		
86	3689.3	198.1	113.8	53.4	116	6477.6	253.6	147.4	65.4
87	3767.4	200.2			117	6585.6	255.2		
88	3846.0	202.1	115.7	54.2	118	6697.2	257.0	149.5	66.2
89	3925.1	204.0			119	6807.6	258.8		
90	4004.5	205.8	118.1	55.1	120	6921.6	260.5	151.7	67.0
91	4084.6	207.7			121	7029.6	262.2		
92	4165.0	209.6	120.4	55.9	122	7144.8	264.0	153.7	67.8
93	4246.1	211.7			123	7260.0	265.7		
94	4327.6	213.5	122.6	56.8	124	7376.4	267.5	156.0	68.6
95	4409.4	215.4			125	7492.8	269.2		
96	4491.8	217.2	125.0	57.5	126	7609.2	270.7	158.0	69.5
97	4574.6	219.2			127	7726.8	272.5		
98	4658.0	221.3	127.4	58.3	128	7844.4	274.2	160.1	70.3
99	4742.2	223.1			129	7963.2	275.9		
100	4834.8	225.0	129.8	59.2	130	8082.0	277.6	162.3	71.3

MOMENTS, SHEARS, AND WEIGHTS OF DECK PLATE GIRDERS

COOPER'S E-60 ONE RAIL A.R.E.A. SPECIFICATIONS 1925

SPAN	30	40	50	60	70	80	90	100	110	120	130
	MAXIMUM MOMENT										
Live Load	616	983	1426	1948	2561	3239	4005	4835	5830	6922	8082
Impact	598	933	1312	1739	2201	2670	3153	3626	4154	4677	5170
Dead Load	60	111	198	312	464	742	1013	1344	1739	2295	2958
Total	1274	2027	2936	3999	5226	6651	8171	9805	11723	13894	16210
	MOMENT AT QUARTER POINT										
Live Load	467	759	1105	1507	1957	2473	3118	3795	4548	5322	6166
Impact	453	721	1017	1345	1682	2038	2455	2846	3240	3596	3944
Dead Load	45	83	149	234	348	507	759	1008	1307	1721	2218
Total	965	1563	2271	3086	3987	5068	6332	7649	9095	10639	12328
	MAXIMUM END SHEAR										
Live Load	94.6	113.2	130.8	147.0	165.7	186.2	205.8	225.0	243.0	260.5	277.6
Impact	91.8	107.4	120.2	131.3	142.4	153.5	162.0	168.8	173.1	176.0	177.5
Dead Load	8.1	11.1	15.9	20.8	26.5	37.1	45.0	53.8	60.8	76.5	91.0
Total	194.5	231.7	266.9	299.1	334.6	376.8	412.8	447.6	476.9	513.0	546.1
	SHEAR AT QUARTER POINT										
Live Load	60.0	70.1	80.2	90.1	99.1	108.0	118.1	129.8	140.9	151.7	162.3
Impact	58.3	66.9	75.0	82.4	88.3	93.6	99.2	105.6	110.7	114.8	118.4
Dead Load	4.0	5.6	7.9	10.4	13.3	18.6	22.5	26.9	30.4	38.3	45.5
Total	122.3	142.6	163.1	182.9	200.7	220.2	239.8	262.3	282.0	304.8	326.2
	SHEAR AT CENTER										
Live Load	26.5	33.0	37.3	41.8	46.1	50.5	55.1	59.2	63.1	67.0	71.3
Impact	26.0	32.2	36.1	39.9	43.4	46.9	50.4	53.2	55.7	58.1	60.5
Total	52.5	65.2	73.4	81.7	89.5	97.4	105.5	112.4	118.8	125.1	131.8
	DEAD LOAD PER FOOT OF SPAN										
Girders & Bracing	575	670	770	885	1015	1155	1300	1450	1600	1750	1900
Track	500	500	500	500	500	700	700	700	700	800	900

WEIGHTS OF SINGLE TRACK DECK GIRDER SPANS
E-60 LOADING A.R.E.A. SPECIFICATIONS 1925

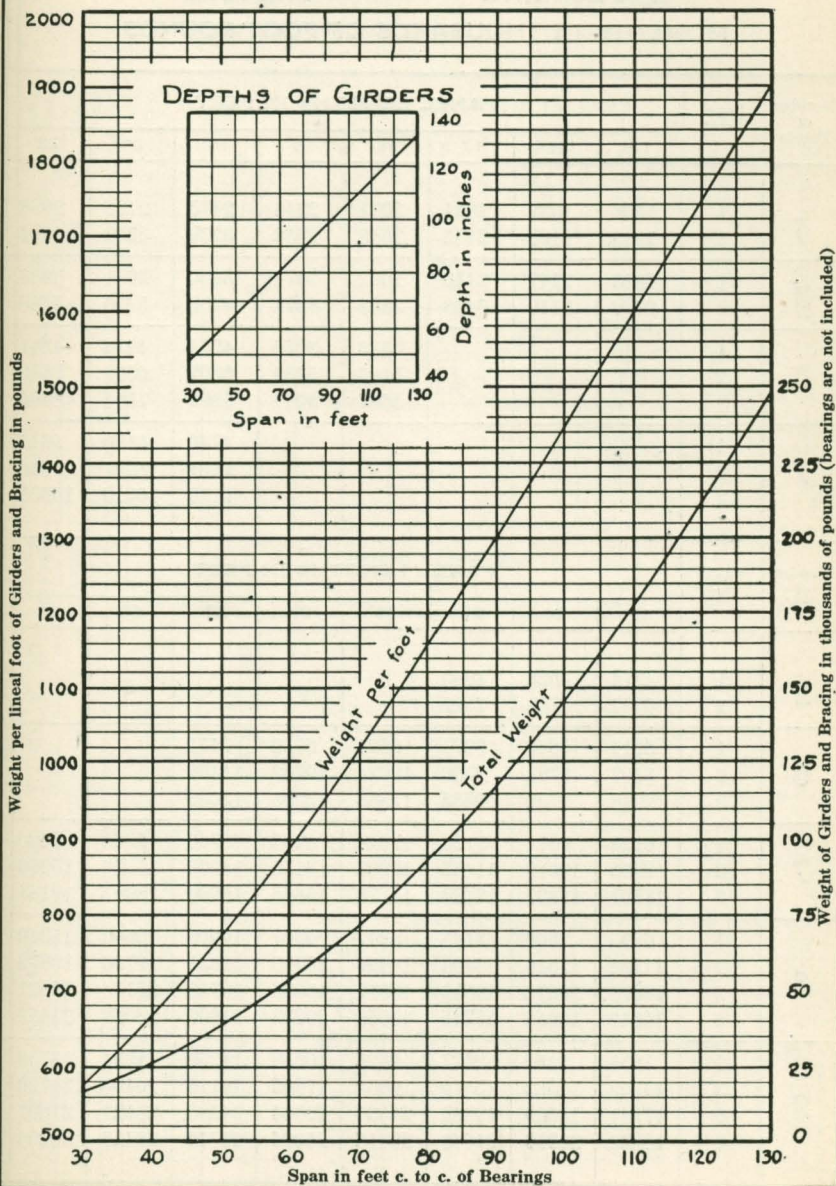

BENDING MOMENTS IN TRUSSES**E-60 LOADING****ONE RAIL****MOMENTS IN THOUSANDS OF FOOT POUNDS**

Number of Panels	Panel Point	PANEL LENGTHS IN FEET							
		15	16	17	18	19	20	21	22
4	1	1508	1682	1864	2051	2246	2475	2728	2988
	2	1942	2183	2435	2688	2956	3239	3533	3844
5	1	1898	2147	2413	2692	2974	3280	3601	3934
	2	2772	3119	3468	3854	4274	4732	5216	5720
6	1				3323	3676	4034	4414	4811
	2				5166	5734	6307	6899	7499
	3				5587	6217	6895	7585	8305
7	1						4746	5180	5642
	2						7591	8297	9036
	3						9175	10016	10895
Number of Panels	Panel Point	PANEL LENGTHS IN FEET							
		23	24	25	26	27	28	29	30
5	1	4274	4622	4980					
	2	6232	6768	7312					
6	1	5219	5640	6074	6521	6979	7451		
	2	8107	8723	9352	10024	10752	11496		
	3	9046	9799	10585	11388	12205	13036		
7	1	6120	6614	7123	7648	8188	8743	9314	9900
	2	9806	10610	11435	12282	13175	14090	15026	15996
	3	11791	12731	13734	14776	15845	16936	18047	19181
8	1	6995	7560	8144	8747	9367	10007	10660	11340
	2	11568	12516	13493	14496	15540	16625	17736	18876
	3	14371	15578	16813	18077	19396	20743	22118	23521
	4	15349	16555	17785	19050	20358	21690	23053	24487
9	1	7851	8490	9147	9825	10530	11250	11994	12759
	2	13299	14382	15510	16668	17865	19116	20406	21720
	3	17241	18369	19533	21333	22884	24486	26124	27801
	4	18822	20316	21846	23418	25004	26712	28413	30204

SHEARS IN TRUSSES
E-60 LOADING ONE RAIL
SHEARS IN THOUSANDS OF POUNDS

Number of Panels	Panel Point	PANEL LENGTHS IN FEET							
		15	16	17	18	19	20	21	22
4	1	100.4	104.8	108.7	113.4	118.1	123.7	129.8	135.8
	2	48.8	51.4	54.0	56.6	59.3	61.6	63.7	65.9
	3	12.7	14.0	15.2	16.2	17.2	18.0	18.7	19.4
5	1	126.5	134.2	142.0	149.5	156.5	163.9	171.5	178.8
	2	76.1	79.6	82.9	86.9	90.8	94.9	99.1	103.3
	3	37.4	39.5	41.2	43.0	44.8	46.4	48.2	49.9
6	1	8.6	9.8	10.8	11.6	12.5	13.2	13.9	14.4
	2				184.7	193.4	201.7	210.2	218.6
	3				121.4	127.4	133.3	139.2	144.8
7	1				70.7	73.3	76.2	79.9	83.5
	2				34.7	36.2	37.7	39.2	40.7
	3				8.6	9.4	10.0	10.6	11.2
8	1						237.2	240.7	256.4
	2						170.4	177.5	184.3
	3						111.7	117.0	121.9
9	1						64.3	66.6	69.4
	2						31.4	32.9	34.1
	3						7.7	8.3	8.8
Number of Panels	Panel Point	PANEL LENGTHS IN FEET							
		23	24	25	26	27	28	29	30
5	1	185.9	192.6	199.2					
	2	107.9	112.1	116.0					
	3	51.5	53.0	54.6					
	4	15.0	15.5	16.1					
6	1	226.9	235.0	243.0	250.8	258.5	266.0		
	2	150.5	156.1	161.4	166.8	172.2	177.6		
	3	87.5	91.1	94.3	97.8	101.2	104.4		
	4	42.0	43.3	44.6	45.8	47.0	48.2		
	5	11.6	12.1	12.6	13.1	13.6	14.0		
7	1	266.0	275.6	284.9	294.1	303.2	312.2	321.1	330.0
	2	191.0	197.8	204.2	211.0	217.8	224.4	231.0	237.5
	3	126.8	131.8	136.3	140.9	145.3	149.6	154.0	158.2
	4	72.8	76.0	79.0	82.0	84.8	87.7	90.5	93.4
	5	35.3	36.5	37.6	38.6	39.7	40.8	41.9	42.8
	6	9.2	9.6	10.2	10.6	11.0	11.4	11.8	12.2
8	1	304.1	315.0	325.8	336.4	346.9	357.4	367.7	378.0
	2	230.0	238.0	245.9	253.9	262.0	270.0	277.9	285.8
	3	165.4	171.2	177.1	182.8	188.4	193.8	199.4	204.8
	4	109.2	113.5	117.6	121.6	125.5	129.4	133.2	137.0
	5	62.5	65.0	67.7	70.1	72.6	75.2	77.8	80.2
	6	30.2	31.3	32.3	33.2	34.2	35.2	36.1	37.0
	7	7.4	7.8	8.3	8.7	9.1	9.5	9.8	10.2
9	1	341.4	354.0	366.0	378.0	390.0	402.0	413.7	425.4
	2	267.9	277.2	286.5	296.1	305.4	315.0	324.3	333.3
	3	202.8	210.0	216.9	224.1	231.0	237.6	244.5	251.4
	4	145.5	150.6	156.0	160.8	166.2	171.0	175.8	180.6
	5	95.4	99.3	102.9	106.8	110.1	113.7	117.0	120.6
	6	54.9	57.0	59.4	61.8	63.9	66.0	68.1	70.2
	7	25.5	26.2	27.2	28.2	29.2	30.3	31.5	32.6
	8	6.0	6.4	6.8	7.1	7.5	7.9	8.2	8.6

STRESSES IN VIADUCT COLUMNS DUE TO TEMPERATURE CHANGES

Δ = movement in inches to one side = $.0000065 \times \frac{T^\circ}{2} \times 12D$ { where D = the distance in lin. ft. to the nearest fixed point.
 l = length of Col. in inches; L = do. in feet, = $\frac{l}{12}$
 d = distance in inches from neutral axis to extreme fibre, in direction of movement.
 T = change of Temperature in degrees Fahrenheit.
 f = maximum fibre stress due to Temperature Bending ($= \frac{Md}{I}$)
 E = Modulus of Elasticity = 29,000,000.

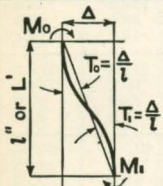

Case 1—Fixed Top & Bottom.

$$T_0 = T_1 = \frac{\Delta}{l} = \frac{Ml}{6EI} \therefore M = M_0 = M_1 = \frac{6EI\Delta}{l^2}$$

$$f = \frac{6E\Delta d}{l^2} = \frac{1,208,400 \Delta d}{L^2} \text{ (Top \& bottom)}$$

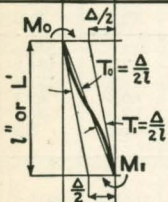

Case 2 { Half Fixed Top.
Half Fixed Bot.

$$T_0 = T_1 = \frac{\Delta}{2l} = \frac{Ml}{6EI} \therefore M = M_0 = M_1 = \frac{3EI\Delta}{l^2}$$

$$f = \frac{3E\Delta d}{l^2} = \frac{604,200 \Delta d}{L^2} \text{ (Top \& bottom)}$$

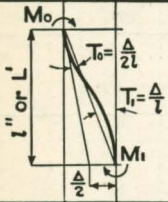

Case 3 { Half Fixed Top.
Fixed Bot.

$$T_0 = \frac{\Delta}{2l} = \frac{l}{6EI}(2M_0 - M_1) \quad \left. \begin{array}{l} T_1 = \frac{\Delta}{l} = \frac{l}{6EI}(2M_1 - M_0) \\ \therefore M_0 = \frac{4EI\Delta}{l^2} \\ M_1 = \frac{5EI\Delta}{l^2} \end{array} \right\}$$

$$f_0 = \frac{4E\Delta d}{l^2} = \frac{805,600 \Delta d}{L^2} \text{ (Top)}$$

$$f_1 = \frac{5E\Delta d}{l^2} = \frac{1,007,000 \Delta d}{L^2} \text{ (Bot.)}$$

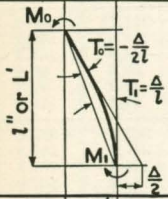

Case 4 { Pin at Top.
Fixed Bot.

$$T_0 = -\frac{\Delta}{2l} = \frac{l}{6EI}(2M_0 - M_1) \quad \left. \begin{array}{l} T_1 = \frac{\Delta}{l} = \frac{l}{6EI}(2M_1 - M_0) \\ \therefore M_0 = 0 \\ M_1 = \frac{3EI\Delta}{l^2} \end{array} \right\}$$

$$f_0 = 0 \text{ (Top)}$$

$$f_1 = \frac{3E\Delta d}{l^2} = \frac{604,200 \Delta d}{L^2} \text{ (Bot.)}$$

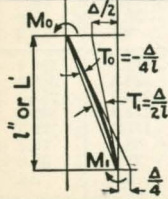

Case 5 { Pin at Top.
Half Fixed Bot.

$$T_0 = -\frac{\Delta}{4l} = \frac{l}{6EI}(2M_0 - M_1) \quad \left. \begin{array}{l} T_1 = \frac{\Delta}{2l} = \frac{l}{6EI}(2M_1 - M_0) \\ \therefore M_0 = 0 \\ M_1 = \frac{3EI\Delta}{2l^2} \end{array} \right\}$$

$$f_0 = 0 \text{ (Top)}$$

$$f_1 = \frac{3E\Delta d}{2l^2} = \frac{302,100 \Delta d}{L^2} \text{ (Bot.)}$$

WEIGHTS OF SINGLE TRACK THROUGH TRUSS SPANS

E-60 LOADING · A.R.E.A. SPECIFICATIONS 1925

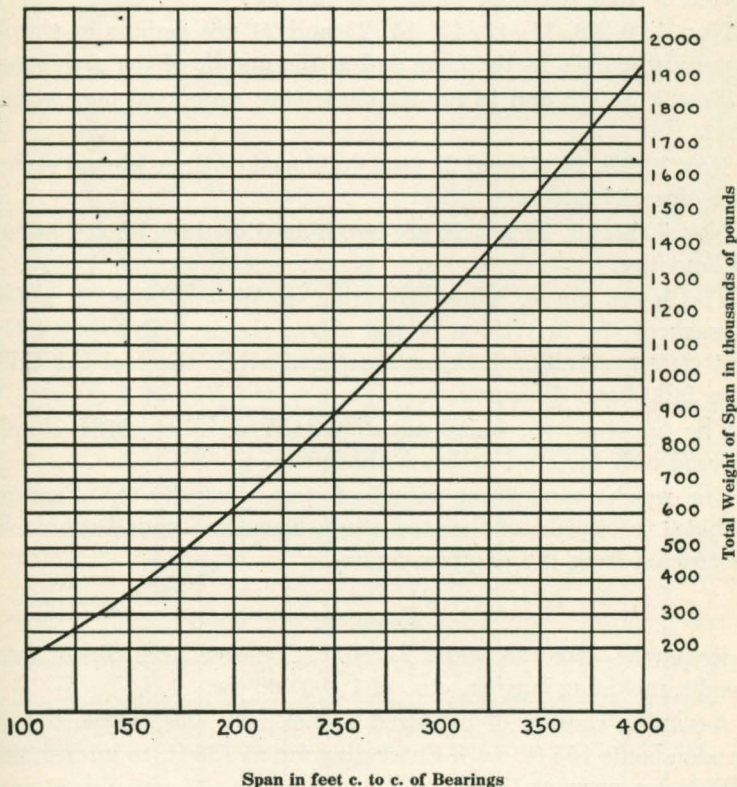

STEEL CENTERING FOR CONCRETE ARCHES

The curves on the opposite page can be used for estimating the weight of steel trusses and bracing for centering concrete arches. The weights of wedges or other lowering devices, and of the supporting bents are not included.

The trusses are designed with top chords approximately fitting the intrados of the arch, and spaced so as to receive lagging supported on nailers bolted to the top chords.

Nos. 1, 9, 10, 11, 12, 13, 15, 23 and 24 are designs of simple trusses supported at the piers and at the middle of the arch span.

Nos. 2, 3, 6, 8 and 14 are simple trusses supported only at the piers.

Nos. 16, 18, 20, 21 and 22 are two hinged or three hinged arches with ties.

Nos. 7, 17, 19, 25 and 26 are two hinged or three hinged arches without ties.

The lower curve, whose equation is $W = \frac{800}{L} + 8$, is a fair average of the first three of the above classes. Designs of the first class generally fall below the curve, while those of the third class fall above the curve.

The upper curve, whose equation is $W = \frac{2400}{L} + .019L$ should be used only for steel arches without ties.

The weight carried per pound of steel, given by the diagram, includes the weight of the steel itself, hence one pound should be subtracted from the diagram figure.

Example

Required:—Steel to center 2-160 ft. Concrete Arch ribs of total weight, including lagging, etc., of 1,400,000 lbs.

Assuming centers of 3 hinged arches with ties, supported on wooden bents 155 ft. c.c.—Enter diagram at 155 ft. to intersection with lower curve at 13.2 lbs.

Approx. wt. of steel = $1,400,000 \div (13.2 - 1.0) = 114,800$ lbs.

Assuming centers of simple trusses supported on wooden bents both at the piers and at the middle of the arch span, 77 ft. c.c.

Approx. wt. of steel = $1,400,000 \div (18.3 - 1.0) = 81,000$ lbs.

STEEL CENTERING FOR CONCRETE ARCHES CURVES FOR WEIGHT SUPPORTED PER POUND OF STEEL

NOTE:—Curves apply only within span limits shown, and not for very light loads.

UNIT STRESSES:—

Tension:— 20000 lbs. per sq. inch.

Compression:—20000— $88 \frac{1}{r}$ (17000 Max.).

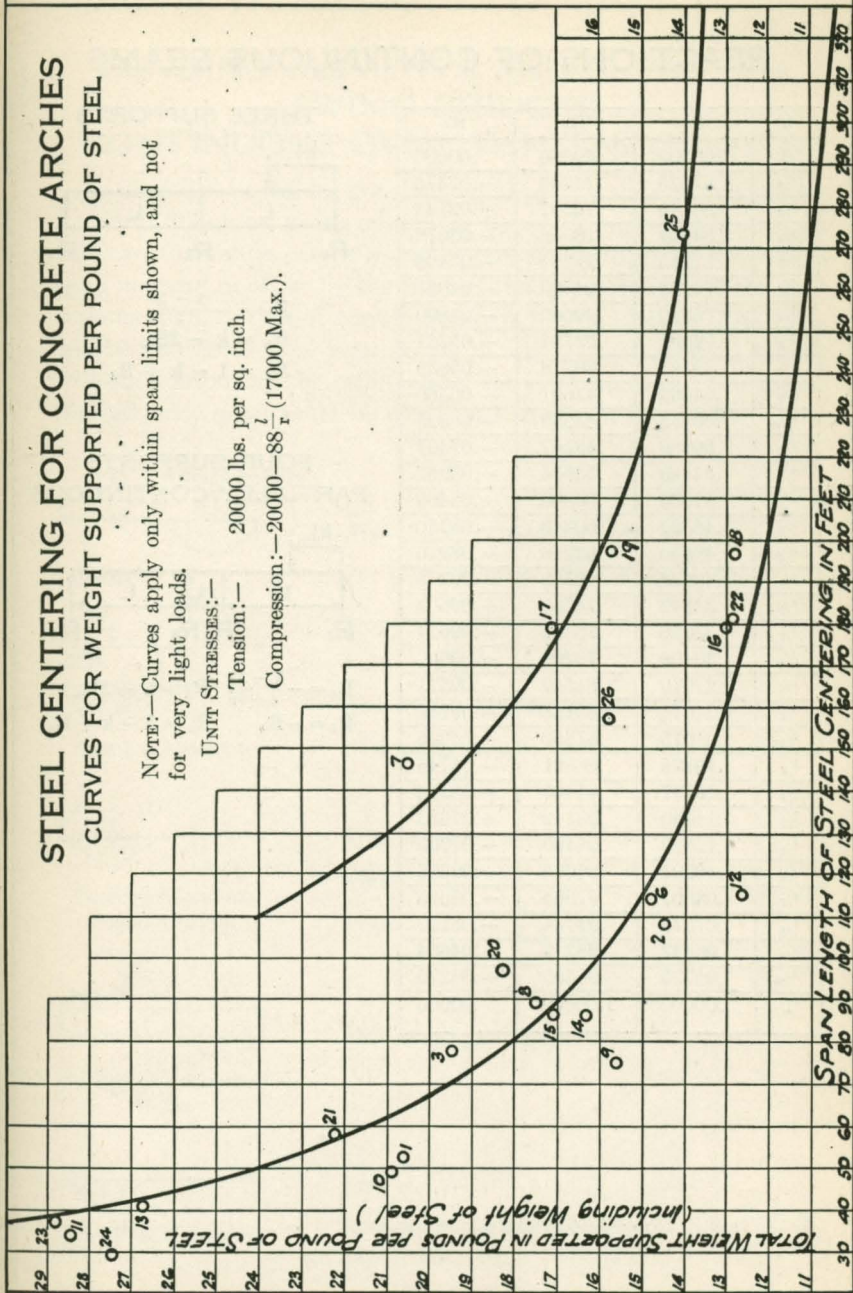

REACTIONS OF CONTINUOUS BEAMS

k	R ₁	R ₂	R ₃
0	1.00000	.00000	.00000
1/10	.87525	.14950	-.02475
1/9	.86146	.16597	-.02743
1/8	.84424	.18652	-.03076
1/7	.82215	.21284	-.03499
1/6	.79282	.24769	-.04051
1/5	.75200	.29600	-.04800
2/9	.72497	.32784	-.05281
1/4	.69141	.36718	-.05859
2/7	.64869	.41691	-.06560
3/10	.63175	.43650	-.06825
1/3	.59260	.48147	-.07407
3/8	.54443	.53614	-.08057
2/5	.51600	.56800	-.08400
3/7	.48397	.60349	-.08746
4/9	.46640	.62276	-.08916
1/2	.40625	.68750	-.09375
5/9	.34842	.74760	-.09602
4/7	.33236	.76385	-.09621
3/5	.30400	.79200	-.09600
5/8	.27979	.81542	-.09521
2/3	.24074	.85185	-.09259
7/10	.21075	.87850	-.08925
5/7	.19825	.88921	-.08746
3/4	.16797	.91406	-.08203
7/9	.14540	.93142	-.07682
4/5	.12800	.94400	-.07700
5/6	.10301	.96065	-.06366
6/7	.08601	.97084	-.05685
7/8	.07373	.97754	-.05127
8/9	.06447	.98217	-.04664
9/10	.05725	.98550	-.04275
1	.00000	1.00000	.00000

THREE SUPPORTS

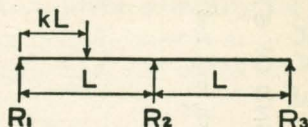

$$R_3 = -\frac{k - k^3}{4}$$

$$R_2 = k - 2R_3$$

$$R_1 = 1 - k + R_3$$

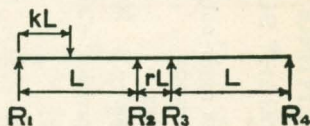
FOUR SUPPORTS
PARTIALLY CONTINUOUS

$$R_4 = -\frac{k - k^3}{4 + 6r} \quad R_2 = k - 2R_4$$

$$R_3 = -R_4 \quad R_1 = 1 - k + R_4$$

BENDING MOMENTS AND SHEARS IN SWING BRIDGES CONTINUOUS OVER THREE SUPPORTS

In the following tables are given bending moments and shears for four and five panel swing spans, for the continuous condition. In all cases the values can be found closely by multiplying the simple span moment or shear by the ratio of the influence area of the continuous span, to that of the simple span, for the point. This ratio can be determined for *moments* by means of the equations below, without computing the ordinates of the influence line. For *shears* the influence areas must be computed to obtain the ratios.

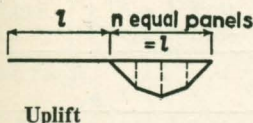

Area of influence line for uplift = $\frac{l}{16}$
For paneled bridge. Area = $\frac{l}{16} \left(\frac{n^2-1}{n^2} \right)$

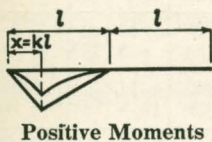

Area for simple span = $\frac{x(l-x)}{2}$
Area for continuous span = $\frac{x(l-x)}{2} - \frac{lx}{16}$
Ratio = $1 - \frac{1}{8} \frac{1}{(1-k)}$

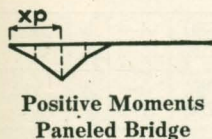

Area for simple span = $\frac{p^2x(n-x)}{2}$
Area for continuous span = $\frac{p^2x(n-x)}{2} - \frac{nxp^2 \cdot n^2 - 1}{16 \cdot n^2}$
Ratio = $1 - \frac{1}{8} \cdot \frac{n^2-1}{n(n-x)}$

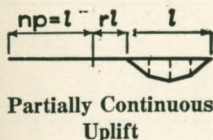

Area = $\frac{l}{16+24r} \cdot \frac{n^2-1}{n^2}$

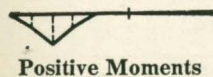

Area = $\frac{p^2x(n-x)}{2} - \frac{nxp^2}{16+24r} \cdot \frac{n^2-1}{n^2}$
Ratio to area for simple span = $1 - \frac{1}{8+12r} \cdot \frac{n^2-1}{n(n-x)}$

BENDING MOMENTS IN EIGHT PANEL SWING BRIDGE

THREE SUPPORTS—E-60 LOADING ONE RAIL

Conditions of loading: Any length of uniform load following one or two engines, no uniform load in front of engines, loading continuous, wheels of the tender are not separated from the drivers. These conditions apply also to the three tables following.

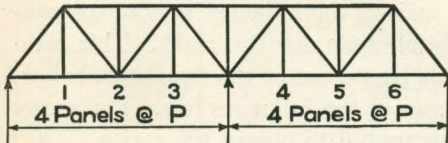

Influence lines for values $\frac{M}{P}$

$\frac{1}{4}$ Point

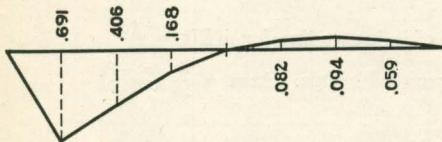

$$\frac{1.265}{1.5} = .843 \text{ Ratio to simple span area}$$

$\frac{1}{2}$ Point

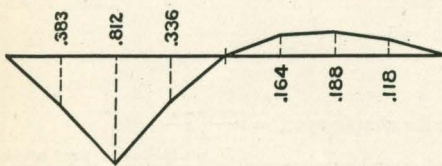

$$\frac{1.531}{2.0} = .766 \text{ Ratio to simple span area}$$

$\frac{3}{4}$ Point

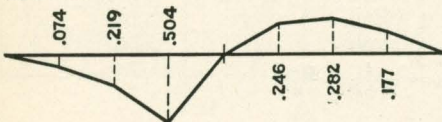

$$\frac{.797}{1.5} = .531 \text{ Ratio to simple span area}$$

Center

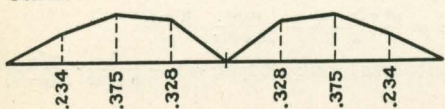

Panel length	Moment Ft.-kips	Wheel at point	Ratio to simple span M
20	2059	12→	.833
	-368	15→	
25	3214	13→	.847
	-577	←8	
30	4512	←5	.848
	-818	14→	

20	2510	←13	2	.775
	-736	15→		
25	3728	←12	2	.772
	-1154	←8		
30	5303	←11	2	.769
	-1636	14→		

20	1380	4→	3	.558
	-1104	15→		
25	2063	4→	3	.544
	-1732	←8		
30	2873	5→	3	.540
	-2454	14→		

20	2548	←10	2
25	4052	←12	1.8' left 3
			3
30	5803	←14	3

SHEARS IN EIGHT PANEL SWING BRIDGE

THREE SUPPORTS—E-60 LOADING ONE RAIL

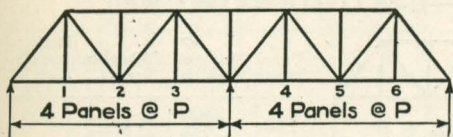

2nd Panel

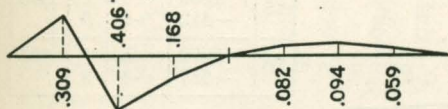

$$\frac{.468}{.667} = .730 \text{ Ratio to simple span area.}$$

$$\frac{.221}{.167} = 1.325 \text{ " " " " " "}$$

3rd Panel

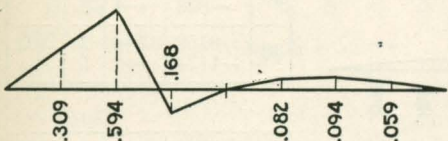

$$\frac{.837}{.667} = 1.255 \text{ Ratio to simple span area}$$

4th Panel

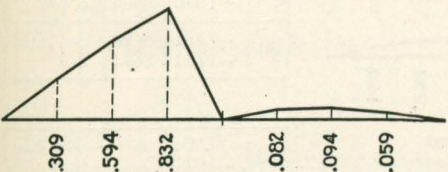

$$\frac{1.734}{1.5} = 1.156 \text{ Ratio to simple span area}$$

Center Reaction

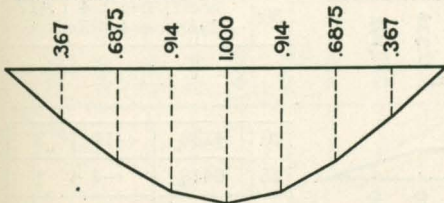

$$\frac{4.937}{4.0} = 1.234 \text{ Ratio to simple span area}$$

Panel length	Shear kips	Wheel at point	Ratio to simple span shear
20	+45.7	←3	.743
	-22.7	3→	1.26
25	+54.1	←3	.755
	-28.0	3→	1.31
30	+57.0	←4	.691
	-22.3	3→	1.33

20	-76.2	3→	2	1.238
	-77.6	←5	2	
25	-87.8	3→	2	1.226
	-86.4	←6	2	
30	-100.0	4→	2	1.212
	-95.8	←8	2	

20	-142.0	4→	3	1.147
	-153.7	←13	3	
25	-175.0	4→	3	1.153
	-191.9	←13	3	
30	-204.7	5→	3	1.153
	-225.6	←14	3	

Center Reaction

20	361.7	←5	2	1.213
25	431.9	14	Center	1.214
30	501.2	←2	1	1.225

BENDING MOMENTS IN TEN PANEL SWING BRIDGE

THREE SUPPORTS—E-60 LOADING ONE RAIL

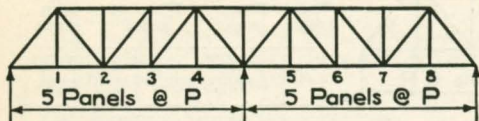

Influence lines for values of $\frac{M}{P}$

$\frac{1}{5}$ Point

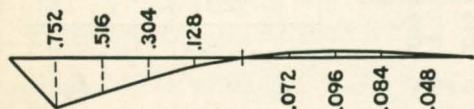

$\frac{1.7}{2.0} = .85$ Ratio to simple span area

$\frac{2}{5}$ Point

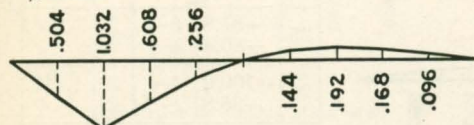

$\frac{2.4}{3.0} = .80$ Ratio to simple span area

$\frac{3}{5}$ Point

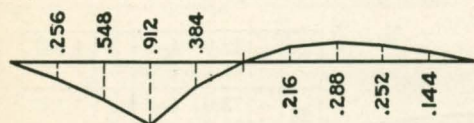

$\frac{2.1}{3.0} = .70$ Ratio to simple span area

$\frac{4}{5}$ Point

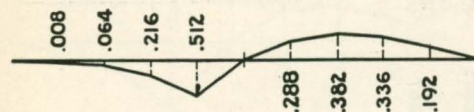

$\frac{0.8}{2.0} = .40$ Ratio to simple span area

Center

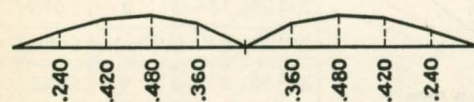

Panel Moment length Ft.-kips Wheel at point Ratio to simple span M

20	2800	←4	1	.854
	-259	←7	6	
25	4259	←4	1	.855
	-412	←4	5	
30	5922	←5	1	.857
	-587	←4	5	

20	3799	12→	2	.803
	-519	←7	6	
25	5860	12→	2	.801
	-823	←4	5	
30	8162	13→	2	.803
	-1174	←4	5	

20	3348	←12	3	.708
	-778	←7	6	
25	5152	←12	3	.705
	-1235	←4	5	
30	7181	←13	3	.706
	-1761	←4	5	

20	1394	4→	4	.425
	-1037	←7	6	
25	2070	4→	4	.416
	-1646	←4	5	
30	2880	5→	4	.417
	-2348	←4	5	

20	4139	←10	3
25	6418	←4	1
30	9047	←13	3

SHEARS IN TEN PANEL SWING BRIDGE

THREE SUPPORTS—E-60 LOADING ONE RAIL

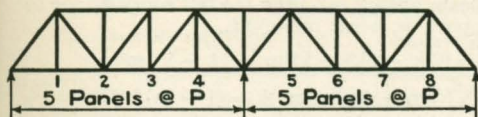

2nd Panel

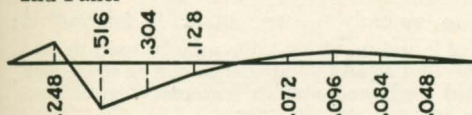

$$\frac{.8642}{1.125} = .768 \text{ Ratio to simple span area}$$

$$\frac{.1642}{.125} = 1.314 \text{ " " " " " "}$$

3rd Panel

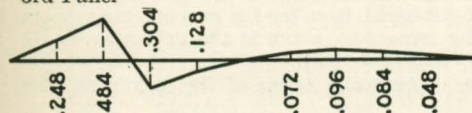

$$\frac{.3386}{.5} = .677 \text{ Ratio to simple span area}$$

$$\frac{.6386}{.5} = 1.277 \text{ " " " " " "}$$

4th Panel

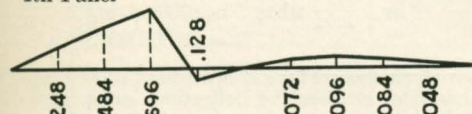

$$\frac{1.374}{1.125} = 1.221 \text{ Ratio to simple span area}$$

5th Panel

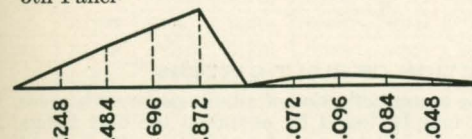

$$\frac{2.3}{2.0} = 1.15 \text{ Ratio to simple span area}$$

Center Reaction

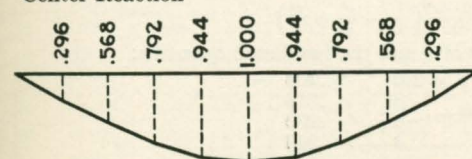

$$\frac{6.2}{5.0} = 1.24 \text{ Ratio to simple span area}$$

Panel length Shear kips Wheel at point Ratio to simple span shear

20	+68.4	←3	2	.721
	-23.6	←7	6	
25	+88.4	←4	2	.758
	-29.2	←4	5	
30	+106.0	←4	2	.774
	-33.7	←4	5	

20	+32.4	←2	3	.698
	-59.0	3→	2	
25	+38.3	←2	3	.701
	-69.0	3→	2	
30	+43.6	←2	3	.689
	-79.2	3→	2	

20	-114.2	3→	3	1.204
	-125.2	←13	3	
25	-140.5	4→	3	1.212
	-156.0	←13	3	
30	-165.2	4→	3	1.209
	-184.1	←14	3	

20	-187.6	4→	4	1.145
	-204.1	←13	4	
25	-228.4	4→	4	1.147
	-244.1	←14	4	
30	-263.8	5→	4	1.145
	-275.9	←14	4	

Center Reaction

20	434.2	14	Center	1.221
25	520.4	17	Center	1.235
30	607.1	←11	.7' left	1.244

Center

DEFLECTIONS

The deflection at a point of a beam distant mL from the left support, due to a load distant kL from the support, is, when $mL < kL$,

$$D = \frac{PL^3}{6EI} [(2k - 3k^2 + k^3)m - (1 - k) m^3]$$

and when $mL > kL$,

$$D = \frac{PL^3}{6EI} [(2m - 3m^2 + m^3)k - (1 - m) k^3]$$

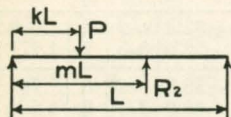
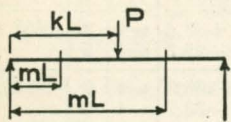

The table on the opposite page gives values by which to multiply $\frac{PL^3}{EI}$ to obtain D for various values of k and m . This table may be used to find the deflection at any point due to one or more concentrated loads and also to find reactions of continuous beams in certain cases.

$$\text{Let } k = .25 \text{ and } m = .65$$

$$R_2 = P \frac{D_{mk}}{D_{mm}} = P \frac{.01189}{.01725} = .6893P$$

D_{mk} is the deflection at the support R_2 , due to a load P , distant kL from the left support, the support R_2 being removed. D_{mm} is the deflection at R_2 , due to a unit load at R_2 .

Formulas giving the deflection of beams in terms of the maximum fiber stress are convenient.

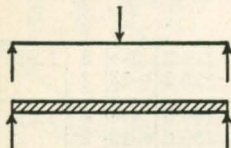

$$D = \frac{24fL^2}{Ed} \quad \text{or} \quad \frac{L^2}{125d} \quad \text{when } f = 10000 \text{ \#/in.}^2$$

$$E = 30,000,000 \text{ \#/in.}^2$$

$$D = \frac{30fL^2}{Ed} \quad \text{or} \quad \frac{L^2}{100d} \quad \text{when } f = 10000 \text{ \#/in.}^2$$

$$E = 30,000,000 \text{ \#/in.}^2$$

D = deflection in inches.

f = maximum fiber stress.

L = length in feet.

E = Young's modulus.

d = depth of symmetrical section in inches.

The above formulas are for a fiber stress of 10000#/in.². For other fiber stresses the deflections are proportional. For unsymmetrical sections d is to be taken as twice the distance from the neutral axis to the most extreme fiber.

CENTER DEFLECTION OF BUILT GIRDERS

An approximate formula for the center deflection of a built girder with cover plates, carrying a uniform load, may be found by assuming the unit flange stress to be uniform and of maximum value beyond the ends of the outermost cover. D is in inches, L is in feet.

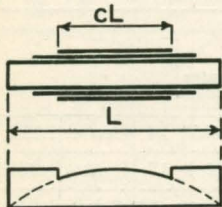

Assumed variation of unit flange stress.

$$D = \frac{144fL^2}{Ed} \left(\frac{1}{4} - \frac{c^3}{6} + \frac{c^4}{8} \right)$$

Values of c and the bracketed quantity:

$c = 1.0$.208
.8	.216
.6	.230
.4	.243
.2	.249
.0	.250

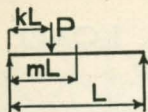

The deflection at any point of a beam supporting a concentrated load $= \frac{PL^3}{EI} \times C$, in which C is a constant whose value is given in the table for values of m and k varying by .05.

$\frac{m}{k}$ or k	.05	.10	.15	.20	.25	.30	.35	.40	.45	.50
.05	.00075	.00141	.00195	.00238	.00272	.00296	.00311	.00319	.00319	.00311
.10	.00141	.00270	.00379	.00467	.00534	.00583	.00615	.00630	.00630	.00617
.15	.00195	.00379	.00542	.00675	.00778	.00853	.00902	.00926	.00928	.00909
.20	.00238	.00467	.00675	.00853	.00994	.01097	.01165	.01200	.01205	.01183
.25	.00272	.00534	.00778	.00994	.01172	.01305	.01395	.01444	.01455	.01432
.30	.00296	.00583	.00853	.01097	.01305	.01470	.01584	.01650	.01671	.01650
.35	.00311	.00615	.00902	.01165	.01395	.01584	.01725	.01811	.01845	.01830
.40	.00319	.00630	.00926	.01200	.01444	.01650	.01811	.01920	.01971	.01967
.45	.00319	.00630	.00928	.01205	.01455	.01671	.01845	.01971	.02042	.02053
.50	.00311	.00617	.00909	.01183	.01432	.01650	.01830	.01967	.02053	.02083
.55	.00298	.00591	.00872	.01136	.01378	.01592	.01772	.01913	.02008	.02053
.60	.00279	.00553	.00818	.01067	.01296	.01500	.01674	.01813	.01913	.01967
.65	.00255	.00506	.00748	.00977	.01189	.01378	.01541	.01674	.01772	.01830
.70	.00227	.00450	.00666	.00870	.01059	.01230	.01378	.01500	.01592	.01650
.75	.00195	.00386	.00572	.00748	.00911	.01059	.01189	.01296	.01378	.01432
.80	.00160	.00317	.00469	.00613	.00748	.00870	.00977	.01067	.01136	.01183
.85	.00122	.00242	.00358	.00469	.00572	.00666	.00748	.00818	.00872	.00909
.90	.00082	.00163	.00242	.00317	.00386	.00450	.00506	.00553	.00591	.00617
.95	.00041	.00082	.00122	.00160	.00195	.00227	.00255	.00279	.00298	.00311

$\frac{m}{k}$ or k	.55	.60	.65	.70	.75	.80	.85	.90	.95
.05	.00298	.00279	.00255	.00227	.00195	.00160	.00122	.00082	.00041
.10	.00591	.00553	.00506	.00450	.00386	.00317	.00242	.00163	.00082
.15	.00872	.00818	.00748	.00666	.00572	.00469	.00358	.00242	.00122
.20	.01136	.01067	.00977	.00870	.00748	.00613	.00469	.00317	.00160
.25	.01378	.01296	.01189	.01059	.00911	.00748	.00572	.00386	.00195
.30	.01592	.01500	.01378	.01230	.01059	.00870	.00666	.00450	.00227
.35	.01772	.01674	.01541	.01378	.01189	.00977	.00748	.00506	.00255
.40	.01913	.01813	.01674	.01500	.01296	.01067	.00818	.00553	.00279
.45	.02008	.01913	.01772	.01592	.01378	.01136	.00872	.00591	.00298
.50	.02053	.01967	.01830	.01650	.01432	.01183	.00909	.00617	.00311
.55	.02042	.01971	.01845	.01671	.01455	.01205	.00928	.00630	.00319
.60	.01971	.01920	.01811	.01650	.01444	.01200	.00926	.00630	.00319
.65	.01845	.01811	.01725	.01584	.01395	.01165	.00902	.00615	.00311
.70	.01671	.01650	.01584	.01470	.01305	.01097	.00853	.00583	.00296
.75	.01455	.01444	.01395	.01305	.01172	.00994	.00778	.00534	.00272
.80	.01205	.01200	.01165	.01097	.00994	.00853	.00675	.00467	.00238
.85	.00928	.00926	.00902	.00853	.00778	.00675	.00542	.00379	.00195
.90	.00630	.00630	.00615	.00583	.00534	.00467	.00379	.00270	.00141
.95	.00319	.00319	.00311	.00296	.00272	.00238	.00195	.00141	.00075

THE CALCULATION OF WHEEL LOAD STRESSES BY MEANS OF INFLUENCE LINES

Let a, b, c, d, e , be an influence line, consisting of a number of straight segments. Let M_1, M_2, M_3, M_4 and M_5 be the static moments of all the loads to the left of points, a, b, c, d and e about a, b, c , etc., respectively. The train is headed toward the left. The tangents of the angles which the segments make with the horizontal are T_1, T_2, T_3 , etc.

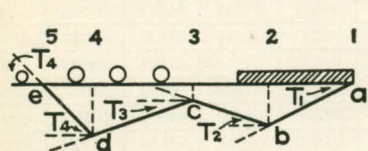

Fig. 1

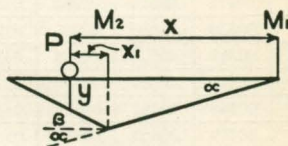

Fig. 2

In figure 2 the influence of the load is P_y

$$P_y = P_x \tan \alpha - P x_1 (\tan \alpha + \tan \beta)$$

$$P_y = M_1 \tan \alpha - M_2 (\tan \alpha + \tan \beta)$$

Similarly the total influence in figure 1 is:—

$$M_1 T_1 - M_2 (T_2 + T_1) + M_3 (T_3 + T_2) - M_4 (T_4 + T_3) + M_5 T_4$$

The form of the influence line determines whether the succeeding products are to be added or subtracted.

If a positive sign is given to the tangents of segments which slope down to the left and a negative sign to those which slope up to the left, the above expression may be generalized as follows:—

$$\text{Influence} = \Sigma M_n (T_n - T_{n-1}) \text{ or } \Sigma (M_n - M_{n+1}) T_n$$

In the first expression each term gives the influence of the loads over the area bounded by the two segments meeting at a point and extending as far as the loads to the left. In the second expression each term gives the influence of the loads over the area bounded by the segment and the horizontal lines through the ends of the segment and extending as far as the loads to the left.

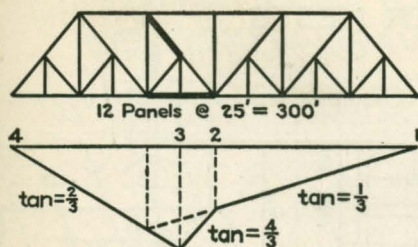

Fig. 3

In figure 3 the influence, bending moment in this case, is:—

$$\frac{1}{3}M_1 + \frac{3}{3}M_2 - \frac{6}{3}M_3 + \frac{2}{3}M_4,$$

$$\text{or } \frac{1}{3}(M_1 - M_2) + \frac{4}{3}(M_2 - M_3) - \frac{2}{3}(M_3 - M_4)$$

For E-60 loading, the critical position is wheel 16 at point 3, train headed left.

M_4 is zero since no wheels are off the span to the left:

$$M_1 \text{ at } 268' = 130201.5 \times \frac{1}{3} = 43400.5$$

$$M_2 \text{ at } 118' = 28,501.5 \times 1 = \underline{28501.5} \quad 72,902$$

$$M_3 \text{ at } 93' = 18,061.5 \times 2 = \underline{36,123}$$

$$M_4 = 0 \text{ (For moments see pages 181 to 183)} \quad \underline{35,779 \text{ ft.-kips}}$$

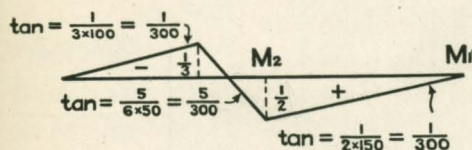

Fig. 4

Figure 4 is the influence line for shear in the diagonal indicated. For positive shear place wheel 4 at the maximum ordinate, train headed left:

$$M_1 \text{ at } 168' = 5490.5 \times \frac{1}{300} = 183.005$$

$$M_2 \text{ at } 18' = 720 \times \frac{6}{300} = \underline{14.400}$$

$$168.61 \text{ kips shear.}$$

This is the usual expression for figuring shear in a panel, the first figure is the left reaction of the truss, and the second the reaction at the left of the panel. In simple cases no influence line is needed.

The above method is general and may be applied to any influence line composed of straight segments.

ROCKER NESTS

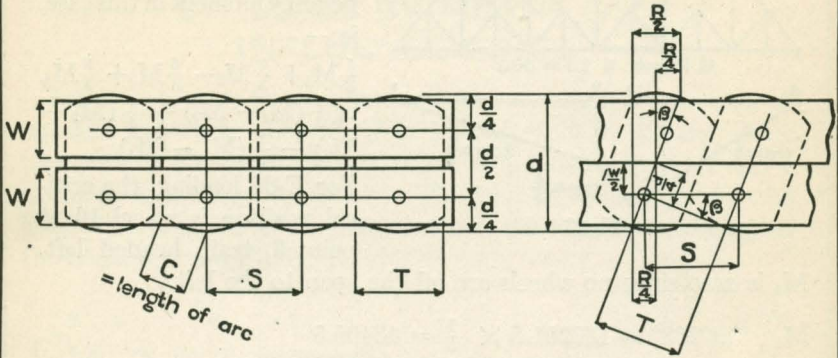

R = Total required Range of Movement

$$\beta = 28.6479 \frac{R}{d} \text{ degrees}$$

$$T = S \cos \beta$$

$$S = \frac{T}{\cos \beta}$$

$$W = \frac{d}{2} \cos \beta$$

C must equal, or exceed, $\frac{R}{4}$

$\frac{T}{d}$	$\frac{A}{d^2}$
.50	0.478
.52	0.496
.54	0.512
.56	0.529
.58	0.546
.60	0.562
.62	0.578
.64	0.593
.66	0.608
.68	0.623
.70	0.638
.72	0.652
.74	0.665
.76	0.679
.78	0.691
.80	0.704

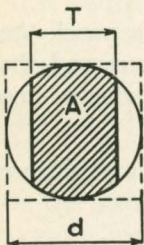

















Table gives area, "A" of cross-section of one roller, for various ratios of $\frac{T}{d}$, as a decimal of the area of the square of its diameter. (Of use in computing weights of rollers.)

DISTANCES FROM BACK OF ANGLES TO CENTER OF GRAVITY OF FLANGE

(in inches)

Total Plate Thickness →		3/8	1/2	3/4	1	1 1/4	1 1/2	1 3/4	2	2 1/4	2 1/2	2 3/4
9'—2 L ^s -6 × 4 ×	Cover Plates 	3/8	1.26	1.10	0.82	0.59	0.38	0.19	0.01
		1/2	1.42	1.27	1.01	0.78	0.57	0.38	0.20	0.03
	1	3/8	1.53	1.40	1.15	0.93	0.73	0.54	0.36	0.19	0.03	..
		1/2	1.63	1.51	1.28	1.06	0.87	0.68	0.51	0.34	0.18	0.02
10'—2 L ^s -6 × 4 ×	Cover Plates 	3/8	1.72	1.60	1.38	1.18	0.99	0.81	0.63	0.47	0.31	0.15
		1/2	1.80	1.68	1.47	1.28	1.09	0.92	0.75	0.58	0.42	0.27
	1	3/8	1.21	1.04	0.76	0.52	0.31	0.12
		1/2	1.37	1.22	0.95	0.71	0.50	0.31	0.13
12'—2 L ^s -5 × 3 1/2 ×	Cover Plates 	3/8	1.49	1.35	1.09	0.86	0.66	0.47	0.29	0.12
		1/2	1.60	1.46	1.22	1.00	0.80	0.61	0.43	0.26	0.10	..
	1	3/8	1.68	1.55	1.32	1.11	0.91	0.73	0.55	0.38	0.22	0.07
		1/2	1.76	1.64	1.42	1.22	1.02	0.84	0.67	0.50	0.34	0.18
14'—2 L ^s -6 × 4 ×	Cover Plates 	3/8	0.42	0.31	0.12
		1/2	0.51	0.41	0.23	0.06
	1	3/8	0.59	0.50	0.32	0.16
		1/2	0.67	0.58	0.40	0.24	0.08
14'—2 L ^s -6 × 4 ×	Cover Plates 	3/8	0.47	0.35	0.16
		1/2	0.57	0.46	0.27	0.10
	1	3/8	0.65	0.55	0.36	0.20	0.04
		1/2	0.73	0.63	0.45	0.29	0.13
14'—2 L ^s -6 × 6 ×	Cover Plates 	3/8	0.80	0.70	0.53	0.37	0.21	0.06
		1/2	0.86	0.77	0.60	0.44	0.28	0.14
	1	3/8	0.95	0.80	0.54	0.32	0.13
		1/2	1.09	0.95	0.70	0.48	0.29	0.11
16'—2 L ^s -6 × 6 ×	Cover Plates 	3/8	1.21	1.08	0.84	0.62	0.43	0.25	0.08
		1/2	1.31	1.18	0.95	0.74	0.55	0.38	0.21	0.04
	1	3/8	1.39	1.27	1.05	0.85	0.66	0.49	0.32	0.16
		1/2	1.46	1.35	1.14	0.94	0.76	0.59	0.42	0.26	0.10	..
16'—2 L ^s -6 × 6 ×	Cover Plates 	3/8	0.90	0.74	0.47	0.25	0.06
		1/2	1.04	0.89	0.63	0.41	0.22	0.04
	1	3/8	1.16	1.02	0.77	0.55	0.35	0.17
		1/2	1.26	1.13	0.88	0.67	0.47	0.29	0.12
16'—2 L ^s -8 × 6 ×	Cover Plates 	3/8	1.35	1.22	0.98	0.77	0.58	0.40	0.23	0.07
		1/2	1.42	1.30	1.07	0.87	0.68	0.50	0.33	0.16	0.01	..
	1	3/8	1.65	1.46	1.13	0.86	0.62	0.41	0.21	0.03
		1/2	1.80	1.62	1.31	1.04	0.81	0.59	0.39	0.21	0.03	..
18'—2 L ^s -8 × 6 ×	Cover Plates 	3/8	1.93	1.76	1.46	1.20	0.96	0.75	0.55	0.36	0.19	0.01
		1/2	2.03	1.87	1.58	1.33	1.10	0.89	0.69	0.51	0.33	0.16
	1	3/8	2.12	1.97	1.69	1.45	1.23	1.02	0.82	0.64	0.46	0.29
		1/2	..	0.78	0.55	0.30	0.16
18'—2 L ^s -8 × 6 ×	Cover Plates 	3/8	..	0.90	0.67	0.47	0.29	0.12
		1/2	..	1.00	0.78	0.58	0.40	0.23	0.07
	1	3/8	..	1.09	0.87	0.68	0.50	0.33	0.17	0.02
		1/2	..	1.16	0.96	0.77	0.60	0.43	0.27	0.11
18'—2 L ^s -8 × 8 ×	Cover Plates 	3/8	..	1.29	1.00	0.74	0.52	0.32	0.14
		1/2	..	1.44	1.15	0.91	0.69	0.49	0.30	0.13
	1	3/8	..	1.57	1.30	1.06	0.84	0.64	0.45	0.27	0.11	..
		1/2	..	1.67	1.41	1.18	0.97	0.77	0.59	0.41	0.24	0.07
20'—2 L ^s -8 × 6 ×	Cover Plates 	3/8	..	1.77	1.52	1.30	1.09	0.89	0.71	0.53	0.36	0.20
		1/2	..	1.85	1.61	1.39	1.12	1.00	0.82	0.64	0.48	0.31
	1	3/8	..	0.74	0.50	0.29	0.11
		1/2	..	0.86	0.62	0.42	0.23	0.06
20'—2 L ^s -8 × 8 ×	Cover Plates 	3/8	..	0.96	0.73	0.53	0.34	0.17	0.01
		1/2	..	1.04	0.82	0.63	0.44	0.27	0.11
	1	3/8	..	1.12	0.91	0.72	0.54	0.36	0.20
		1/2	..	1.23	0.93	0.67	0.45	0.25	0.07
20'—2 L ^s -8 × 8 ×	Cover Plates 	3/8	..	1.38	1.08	0.84	0.62	0.41	0.22	0.05
		1/2	..	1.51	1.23	0.98	0.70	0.56	0.37	0.19	0.02	..
	1	3/8	..	1.62	1.34	1.11	0.98	0.69	0.50	0.33	0.15	..
		1/2	..	1.72	1.46	1.22	1.01	0.81	0.62	0.44	0.27	0.11
1	3/8	..	1.80	1.55	1.32	1.11	0.91	0.73	0.55	0.38	0.22	0.06
	1/2	..	1.80	1.55	1.32	1.11	0.91	0.73	0.55	0.38	0.22	0.06

THE CIRCLE

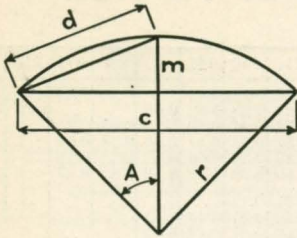

c = chord
 l = length of arc
 m = middle ordinate
 r = radius
 A = angle in degrees

$$m = r \text{ vers. } A = r (1 - \cos A) = r - \sqrt{r^2 - \frac{c^2}{4}}$$

$$d = \sqrt{\frac{c^2}{4} + m^2}$$

$$l = \pi r \frac{A}{90}$$

$$\pi = 3.14159$$

$$m : d :: \frac{d}{2} : r$$

$$r = \frac{c}{2 \sin. A}$$

$$r = \frac{d^2}{2m} = \frac{c^2}{8m} + \frac{m}{2}$$

$$c = 2 r \sin. A$$

$$m = \frac{d^2}{2r} = \frac{c^2}{8r} + \frac{m^2}{2r}$$

$$c = 2 \sqrt{2 mr - m^2}$$

This formula may be used to find the exact value of m by successive approximations to $\frac{m^2}{2r}$ on a slide rule.

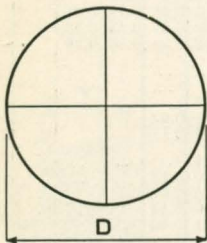

$$\text{Circumference} = \pi d$$

$$\text{Area} = \pi r^2$$

$$\text{Moment of Inertia about a}$$

$$\text{diameter} = \frac{\pi d^4}{64}$$

$$\text{Polar moment of inertia} = \frac{\pi d^4}{32}$$

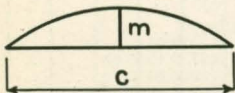

$$\text{Approximate area of circular segment} = mc \left[\frac{2}{3} + .475 \left(\frac{m}{c} \right)^2 \right]$$

THE PARABOLA

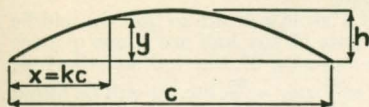

$$y = \frac{4hx}{c^2} (c - x)$$

$$= 4h (k - k^2)$$

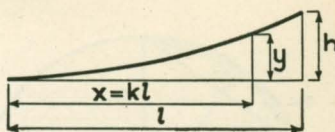

$$y = \frac{hx^2}{l^2} = hk^2$$

CENTROIDS OF PARABOLIC AREAS

$$A = \frac{1}{3} hl$$

$$I_{1-1} = \frac{37}{2100} h^3 l$$

$$I_{2-2} = \frac{1}{80} hl^3$$

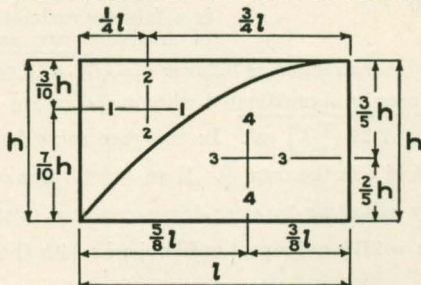

$$A = \frac{2}{3} hl$$

$$I_{3-3} = \frac{8}{175} h^3 l$$

$$I_{4-4} = \frac{19}{480} hl^3$$

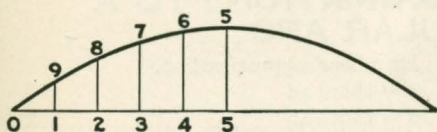

To draw a parabola, number the equally spaced ordinates between the end and the center as shown, then if "h" is the center ordinate the first ordinate is $\frac{9 \times 1}{5 \times 5}$ the second is $\frac{8 \times 2}{5 \times 5}$ etc.

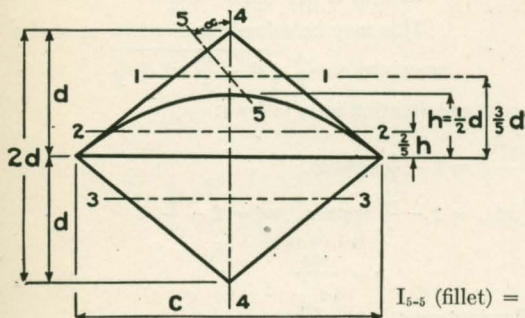

$$I_{1-1} \text{ (fillet)} = \frac{3}{700} cd^3$$

$$I_{2-2} \text{ (parabola)} = \frac{1}{175} cd^3$$

$$= \frac{8}{175} ch^3$$

$$I_{3-3} \text{ (triangle)} = \frac{1}{36} cd^3$$

$$I_{4-4} \text{ (fillet)} = \frac{1}{240} c^3 d$$

$$I_{4-4} \text{ (parabola)} = \frac{1}{60} c^3 d$$

$$I_{4-4} \text{ (triangle)} = \frac{1}{48} c^3 d$$

$$I_{5-5} \text{ (fillet)} = \frac{3}{700} c^3 d \sin^2 \alpha + \frac{1}{240} c^3 d \cos^2 \alpha$$

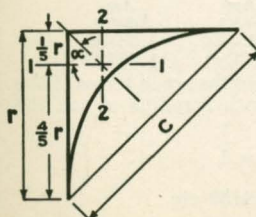

PARABOLIC FILLET IN RIGHT ANGLE

$$\alpha = 45^\circ \quad \sin^2 \alpha = \cos^2 \alpha = \frac{1}{2}$$

$$A = \frac{1}{6} r^2$$

$$I_{1-1} = I_{2-2} = \frac{11}{8400} c^4 = \frac{11}{2100} r^4$$

THE QUARTER ORDINATE CURVE

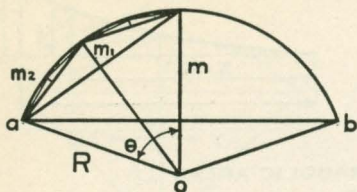

If a curve is drawn so that the middle ordinate of any half arc is one quarter the ordinate of the full arc, that is, $m_1 = \frac{m}{4}$, $m_2 = \frac{m}{4}$, etc., it will be found upon expressing the sum of the lengths of the chords over the arc ab in terms of m and the chord $c = ab$ that the length of the curve is $s = \sqrt{c^2 + \frac{16}{3} m^2}$. This is a fair approximation to the length of a circular arc, and may be made

closer by an empirical correction as follows: $s = \sqrt{c^2 + [5.34 + 2.34(\frac{m}{c})^2] m^2}$. The chord length may be approximated when s and m are given.

$c = \sqrt{s^2 - [5.34 + 2.34(\frac{m}{c})^2] m^2}$. In this case solve for $c = \sqrt{s^2 - \frac{16}{3} m^2}$ and use this value of c in the term $\frac{m}{c}$. If an exact value of c is required, it must be found by adjusting to some trigonometrical relation, $\frac{2m}{c} = \tan \frac{\theta}{2}$, $R = \frac{c^2}{8m} + \frac{m}{2}$, or $s = 2R\theta$ and repeat until s checks with the given value.

OTHER APPROXIMATIONS TO A CIRCULAR ARC

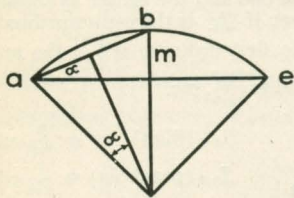

Huyghens' approximation.

c = chord ae

d = chord ab

Length of arc abe $s = \frac{8d-c}{3}$

This may be solved for c when m and s

are given $c = \frac{4}{5} \sqrt{s^2 - \frac{20}{3} m^2} + \frac{8}{5}$

The derivation of another approximation is as follows:

$$\frac{d/2}{s/4} = \frac{\sin \alpha}{\alpha} = \frac{\alpha - \frac{\alpha^3}{6} + \frac{\alpha^5}{120}, \text{ etc.}}{\alpha} = 1 - \frac{\alpha^2}{6} \text{ approx.}$$

$$\frac{c/2}{d} = \cos \alpha = 1 - \frac{\alpha^2}{2} + \frac{\alpha^4}{24}, \text{ etc.} = 1 - \frac{\alpha^2}{2} \text{ approx. } \alpha^2 = 2 - \frac{c}{d}$$

$$\frac{2d}{s} = 1 - \frac{2 - \frac{c}{d}}{6} = \frac{4 + \frac{c}{d}}{6} \quad s = \frac{12d}{4 + \frac{c}{d}}$$

This formula has the following error:

m/c	Arc		m/c	Arc	
	Exact	Approx.		Exact	Approx.
.1	1.02646	1.02645	.4	1.38322	1.38154
.2	1.10347	1.10334	.5	1.57080	1.56722
.3	1.22445	1.22432			

Lengths are in terms of the chord. If the formula is applied to an arc of 60° with a radius of one the length of the arc should be $\pi/3$

$$d = 2 \sin 15^\circ = 2 \sqrt{\frac{1}{2} - \frac{\cos 30^\circ}{2}} = 2 \sqrt{\frac{1}{2} - \frac{1}{4} \sqrt{3}} \quad c = 1$$

$$\frac{\pi}{3} = \frac{12d^2}{4d + c}$$

$$\pi = 3.14152$$

$$\text{True } \pi = 3.14159 \text{ etc.}$$

NOTES

NOTES

NOTES

CONVERSION FACTORS

One board foot	= 144	cubic inches
One centimeter	= 0.3937	inches
One centimeter	= 0.01	meters
One centimeter	= 10	millimeters
One cubic centimeter	= 0.06102	cubic inches
One cubic foot	= 28317	cubic centimeters
One cubic foot	= 0.02832	cubic meters
One cubic foot	= 1728	cubic inches
One cubic foot	= 7.481	gallons
One cubic foot	= 28.317	liters
One cubic inch	= 16.3871	cubic centimeters
One degree (angle)	= 0.01745	radians
One foot	= 0.3048	meters
One foot per second	= 0.6818	miles per hour
One gallon	= 231	cubic inches
One gallon	= 3.7854	liters
One gram	= 0.03528	ounces (Avoirdupois)
One gram per cubic cm.	= 62.435	pounds per cubic foot
One horse-power	= 550	foot-pounds per second
One horse-power	= 0.7457	kilowatts
One inch	= 2.54	centimeters
One kilogram	= 1000	grams
One kilogram	= 2.2046	pounds
One kilogram per sq. mm.	= 1422	pounds per sq. in.
One mile	= 5280	feet
One pound	= 453.59	grams
One pound per sq. in.	= 0.068	atmospheres
One pound per sq. in.	= 2.307	feet of water
One pound per sq. in.	= 2.036	inches of mercury
One pound per sq. in.	= 0.0007031	kilograms per sq. mm.
One radian	= 57.2958	degrees
One square inch	= 6.4516	square cms.
One square foot	= 0.0929	square meters
One ton (long)	= 2240	pounds
One ton (long) per sq. in.	= 1.575	kilograms per sq. mm.

DECIMALS OF AN INCH FOR EACH $\frac{1}{64}$ TH

Fraction	1-32	1-64	Decimal	Fraction	1-32	1-64	Decimal
		1	.015625			33	.515625
	1	2	.03125		17	34	.53125
		3	.046875			35	.546875
$\frac{1}{16}$	2	4	.0625	$\frac{9}{16}$	18	36	.5625
		5	.078125			37	.578125
	3	6	.09375		19	38	.59375
		7	.109375			39	.609375
$\frac{1}{8}$	4	8	.125	$\frac{5}{8}$	20	40	.625
		9	.140625			41	.640625
	5	10	.15625		21	42	.65625
		11	.171875			43	.671875
$\frac{3}{16}$	6	12	.1875	$\frac{11}{16}$	22	44	.6875
		13	.203125			45	.703125
	7	14	.21875		23	46	.71875
		15	.234375			47	.734375
$\frac{1}{4}$	8	16	.25	$\frac{3}{4}$	24	48	.75
		17	.265625			49	.765625
	9	18	.28125		25	50	.78125
		19	.296875			51	.796875
$\frac{5}{16}$	10	20	.3125	$\frac{13}{16}$	26	52	.8125
		21	.328125			53	.828125
	11	22	.34375		27	54	.84375
		23	.359375			55	.859375
$\frac{3}{8}$	12	24	.375	$\frac{7}{8}$	28	56	.875
		25	.390625			57	.890625
	13	26	.40625		29	58	.90625
		27	.421875			59	.921875
$\frac{7}{16}$	14	28	.4375	$\frac{15}{16}$	30	60	.9375
		29	.453125			61	.953125
	15	30	.46875		31	62	.96875
		31	.484375			63	.984375
$\frac{1}{2}$	16	32	.5	1	32	64	1.000

**DECIMALS OF A FOOT
FOR EACH $\frac{1}{32}$ OF AN INCH**

Inch	0"	1"	2"	3"	4"	5"
0	0	.0833	.1667	.2500	.3333	.4167
$\frac{1}{32}$.0026	.0859	.1693	.2526	.3359	.4193
$\frac{1}{16}$.0052	.0885	.1719	.2552	.3385	.4219
$\frac{3}{32}$.0078	.0911	.1745	.2578	.3411	.4245
$\frac{1}{8}$.0104	.0937	.1771	.2604	.3437	.4271
$\frac{5}{32}$.0130	.0964	.1797	.2630	.3464	.4297
$\frac{3}{16}$.0156	.0990	.1823	.2656	.3490	.4323
$\frac{7}{32}$.0182	.1016	.1849	.2682	.3516	.4349
$\frac{1}{4}$.0208	.1042	.1875	.2708	.3542	.4375
$\frac{9}{32}$.0234	.1068	.1901	.2734	.3568	.4401
$\frac{5}{16}$.0260	.1094	.1927	.2760	.3594	.4427
$\frac{11}{32}$.0286	.1120	.1953	.2786	.3620	.4453
$\frac{3}{8}$.0312	.1146	.1979	.2812	.3646	.4479
$\frac{13}{32}$.0339	.1172	.2005	.2839	.3672	.4505
$\frac{7}{16}$.0365	.1198	.2031	.2865	.3698	.4531
$\frac{15}{32}$.0391	.1224	.2057	.2891	.3724	.4557
$\frac{1}{2}$.0417	.1250	.2083	.2917	.3750	.4583
$\frac{17}{32}$.0443	.1276	.2109	.2943	.3776	.4609
$\frac{9}{16}$.0469	.1302	.2135	.2969	.3802	.4635
$\frac{19}{32}$.0495	.1328	.2161	.2995	.3828	.4661
$\frac{5}{8}$.0521	.1354	.2188	.3021	.3854	.4688
$\frac{21}{32}$.0547	.1380	.2214	.3047	.3880	.4714
$\frac{11}{16}$.0573	.1406	.2240	.3073	.3906	.4740
$\frac{23}{32}$.0599	.1432	.2266	.3099	.3932	.4766
$\frac{3}{4}$.0625	.1458	.2292	.3125	.3958	.4792
$\frac{25}{32}$.0651	.1484	.2318	.3151	.3984	.4818
$\frac{13}{16}$.0677	.1510	.2344	.3177	.4010	.4844
$\frac{27}{32}$.0703	.1536	.2370	.3203	.4036	.4870
$\frac{7}{8}$.0729	.1562	.2396	.3229	.4062	.4896
$\frac{29}{32}$.0755	.1589	.2422	.3255	.4089	.4922
$\frac{15}{16}$.0781	.1615	.2448	.3281	.4115	.4948
$\frac{31}{32}$.0807	.1641	.2474	.3307	.4141	.4974
1						

DECIMALS OF A FOOT FOR EACH $\frac{1}{32}$ OF AN INCH

Inch	6"	7"	8"	9"	10"	11"
0	.5000	.5833	.6667	.7500	.8333	.9167
$\frac{1}{32}$.5026	.5859	.6693	.7526	.8359	.9193
$\frac{1}{16}$.5052	.5885	.6719	.7552	.8385	.9219
$\frac{3}{32}$.5078	.5911	.6745	.7578	.8411	.9245
$\frac{1}{8}$.5104	.5937	.6771	.7604	.8437	.9271
$\frac{5}{32}$.5130	.5964	.6797	.7630	.8464	.9297
$\frac{3}{16}$.5156	.5990	.6823	.7656	.8490	.9323
$\frac{7}{32}$.5182	.6016	.6849	.7682	.8516	.9349
$\frac{1}{4}$.5208	.6042	.6875	.7708	.8542	.9375
$\frac{9}{32}$.5234	.6068	.6901	.7734	.8568	.9401
$\frac{5}{16}$.5260	.6094	.6927	.7760	.8594	.9427
$\frac{11}{32}$.5286	.6120	.6953	.7786	.8620	.9453
$\frac{3}{8}$.5312	.6146	.6979	.7812	.8646	.9479
$\frac{13}{32}$.5339	.6172	.7005	.7839	.8672	.9505
$\frac{7}{16}$.5365	.6198	.7031	.7865	.8698	.9531
$\frac{15}{32}$.5391	.6224	.7057	.7891	.8724	.9557
$\frac{1}{2}$.5417	.6250	.7083	.7917	.8750	.9583
$\frac{17}{32}$.5443	.6276	.7109	.7943	.8776	.9609
$\frac{9}{16}$.5469	.6302	.7135	.7969	.8802	.9635
$\frac{19}{32}$.5495	.6328	.7161	.7995	.8828	.9661
$\frac{5}{8}$.5521	.6354	.7188	.8021	.8854	.9688
$\frac{21}{32}$.5547	.6380	.7214	.8047	.8880	.9714
$\frac{11}{16}$.5573	.6406	.7240	.8073	.8906	.9740
$\frac{23}{32}$.5599	.6432	.7266	.8099	.8932	.9766
$\frac{3}{4}$.5625	.6458	.7292	.8125	.8958	.9792
$\frac{25}{32}$.5651	.6484	.7318	.8151	.8984	.9818
$\frac{13}{16}$.5677	.6510	.7344	.8177	.9010	.9844
$\frac{27}{32}$.5703	.6536	.7370	.8203	.9036	.9870
$\frac{7}{8}$.5729	.6562	.7396	.8229	.9062	.9896
$\frac{29}{32}$.5755	.6589	.7422	.8255	.9089	.9922
$\frac{15}{16}$.5781	.6615	.7448	.8281	.9115	.9948
$\frac{31}{32}$.5807	.6641	.7474	.8307	.9141	.9974
1						1.0000

INDEX

	PAGE
A.I.S.C., allowable unit stresses for columns	106
Allowable end reactions for standard I-beams	66-67
Allowable unit stresses in columns	106
" " " in beams unsupported laterally	65
" uniform loads—see Loads.	
" variations in weights of plates	146
Angles:	
allowable uniform loads for angles used as beams	81-102
bulb—see Bulb angles.	
connection angles for standard I-beams	8-17
" " " channels	18-25
crimped angles; distance to first rivet	114
gauges and maximum sizes of rivets	114
properties, equal legs	34-37
" unequal legs	37-49
radii of gyration for two angles, back to back	103-105
spacing of rivets in angles	114-115
Approximations to circular arc	212
Arcs, circular; lengths	160-161; 212
Area of circular sections	162
Area, reduction for rivet holes	119
Areas of circles	166-178, 210
" " circular segments, sectors and zones	162, 163-165, 210
" " irregular figures	147
" " square and round bars	136-139
" " standard structural shapes; method of increasing	5-6
Bars, round and square; upset screw ends	124-125
" " " " weights, areas and dimensions	136-139
Beams:	
angles as beams; allowable uniform loads	81-102
deflection formulas and tables	204-205
deflections, moments and shears for various loadings	108-111
H-columns as beams, allowable uniform loads	80
lateral deflections; notes and table of load reductions	65
reactions of continuous beams	198
Beams, standard I:	
allowable shear, based on web strength	66-67
allowable uniform load, explanation	65
allowable uniform loads, tables	68-74
bearing plates	8-17
bending moments, allowable	8-17
buckling strength of web	66-67
cast iron separators	118
connection angles	8-17
detailing dimensions	8-17
dimensions, American Standard	7

	PAGE
Beams, standard I:	
dimensions and properties	8-17
end reactions allowable, based on web strength	66-67
maximum size of rivet in flanges	8-17
minimum spans of beams, based on web strength	66-67
moments of resistance	8-17
properties	8-17
standard gauges in flanges	8-17
value of connection angles	66-67
wall bearing plates	8-17
weights, dimensions and profiles	8-17
Bearing plates for standard I-beams	8-17
" " " " channels	18-25
" values of pins	127
" values of rivets	116-117
Bending moments, shears and deflections of beams for various loadings	108-111
" " in swing bridges, E-60 loading	199-203
" " in truss spans, E-60 loading	192
" " maximum allowable for standard I-beams	8-17
" " maximum allowable for standard channels	18-25
" " maximum allowable for special channels	26-33
" " of pins	128-129
Bolts and nuts, dimensions and threads	120-121
" " " weights	122
Buckling stresses in beam webs	66-67
Built girders, center of gravity of flanges	209
" " " deflections	204-205
Bulb angles:	
ship building, dimensions and properties	50-53
Button heads for rivets, dimensions and weights	113
Cast iron separators for beams	118
Center of gravity of parabola	211
" " " of plate girder flanges	209
Centering, steel, for concrete arches	196-197
Channels, shipbuilding—see channels, special	
Channels, special:	
bending moments, allowable	26-33
dimensions, American Standard	7
dimensions and properties	26-33
Channels, standard structural:	
allowable uniform loads	75-79
bearing plates	18-25
bending moments, allowable	18-25
connection angles	18-25
detailing dimensions	18-25
dimensions, American Standard	7
maximum size of rivets in flanges	18-25
properties	18-25

	PAGE
Channels, standard structural:	
standard gauges for rivets in flanges	18-25
wall bearing plates	18-25
weights, dimensions and profiles	18-25
Circles, areas and circumferences	166-178, 210
" middle ordinates	210
Circular arc, approximations to length	212
" arcs, length for given chord and rise	160-161
" functions	210
" sections, areas	162
" segments, areas	163-165, 210
Circumferences of circles	166-178, 210
" of round bars	136-139
Clearances for machine driven rivets	114
Columns, allowable unit stresses	106
" H-, allowable concentric loads	61, 80
" " " uniform loads, used as beams	80
" " properties	60-61
" viaduct, stresses due to temperature changes	194
Compound sections, properties	64
Concrete arches, weight of steel centering	196-197
Connection angles for standard I-beams, details	8-17
" " " " " values of	66-67
Connection angles for standard channels, details	18-25
Continuous beams, reaction	198
Conventional signs for riveting	115
Conversion factors	216
Cooper's E-60 loading:	
bending moments and shears in swing bridges	199-203
" " in truss spans	192
equations for length of uniform load for maximum moment	185
equations for maximum moments between various span limits	185
equivalent uniform loads	186-187
maximum moments and shears for various spans, tables	188-189
moments about first wheel at one foot intervals	181-183
moments, shears and weights for deck plate girder spans, table	190
shear in truss spans	193
swing bridges, bending moments and shears	199-203
weights of single track deck girder spans, diagram	191
weights of single track through truss spans, diagram	195
wheel giving maximum moment or maximum concentration	180
Cotters and cotter pins, dimensions	124
Crane rails, weights and dimensions	152
Crimped angles, distance to first rivet	114
Cubes and cube roots of numbers	166-178

	PAGE
Dead load; moments and shears for deck plate girder spans, E-60 loading	190
Decimals of a foot for each $\frac{1}{32}$ nd of an inch	218-219
“ “ an inch for each $\frac{1}{64}$ th	217
Deck girder spans, moments, shears and weights	190-191
Deflection formulas for beams under various loadings	108-110
Deflection of beams and built girders	204-205
Detailing dimensions for standard I-beams	8-17
“ “ “ “ channels	18-25
Diagrams and formulas for beams with various loadings	108-111
Dimensions of bolt heads and nuts	121
“ “ pipe	134-135
“ “ rails	152
“ “ rivet heads	113
“ general, of I-beams and channels, American Standard	7
Dimensions and properties of structural shapes	8-61
Driving clearance of rivets	114
End reactions, allowable for standard I-beams	66-67
Equal angles—see Angles	
Equations for length, of uniform load, for maximum moment, E-60 loading	185
Equations for maximum moments, E-60 loading	185
Equivalents, table of conversion factors	216
Equivalent uniform loads, E-60 loading	186-187
Explanatory notes on standard structural shapes	5-6
Factors, conversion	216
Fiber stress, allowable—see Stresses, allowable	
Field rivets, lengths for various grips	112
Fillet, parabolic	211
Flanges of plate girders, center of gravity	209
Flat rolled steel, allowable overrun	146
“ “ “ weight	140-145
Flexure, lateral; notes and table of load reductions	65
Formulas and diagrams for beams under various loadings	108-111
Fractions of an inch in decimals of a foot	218-219
Fractions of an inch in decimals of an inch	217
Framing distances for standard I-beams and channels	8-25
Functions of angles, natural trigonometric	154-159
“ “ numbers	166-178
Gauges for rivet holes in angles	114
“ “ “ “ “ standard I-beams and channels	8-25
“ wire and sheet metal	123

	PAGE
General conditions, as to specifications, weights, ordering and billing	5
General dimensions of I-beams and channels	7
Girders, built; deflections	204-205
" center of gravity of flanges	209
" deck plate spans; moments, shears and weights	190-191
Grip of rivets and bolts through flanges of I-beams and channels	8-25
Grips; length of rivets for various grips	112
H-columns; allowable concentric loads	61, 80
" allowable uniform loads used as beams	80
" properties, weights and dimensions	60-61
Huyghens' approximation to a circular arc	212
Inertia, moment of, for rectangles	148-151
Influence lines; for calculation of wheel load stresses	206-207
Lateral strength of beams; notes and tables	65
Length of circular arcs for given chord and rise	160-161
" " rivets for various grips	112
" " uniform loads for maximum moment, E-60 loading	185
List—general, of sections rolled	4
Loading, Cooper's E-60—see Cooper's loading	
Loads, allowable concentric for H-columns	61, 80
Loads, allowable uniform:	
for angles used as beams, equal legs	81-85
" " " " " unequal legs, short leg horizontal	86-94
" " " " " unequal legs, long leg horizontal	95-102
for H-columns used as beams	80
for standard I-beams	68-74
for standard channels	75-79
reduction of, for laterally unsupported beams	65
Loads, equivalent uniform, E-60 loading	186-187
Machine riveting; pitch required for clearance	114
Material; specifications	5
Mathematical tables	153-178
Maximum concentrations, wheel determinations, E-60 loading	180
Maximum moments; equations, E-60 loading	185
Maximum moments and shears, various spans, E-60 loading	188-190
Maximum safe shear for standard I-beams based on web strength	66-67

	PAGE
Method of increasing area of standard structural shapes	6
Minimum spacing for rivets	114-115
" spans for standard I-beams based on web strength	66-67
Moment of inertia of a compound section	64
" " " rectangles	148-151
" " " resistance of pins	128-129
" " " " standard I-beams	8-17
" " " " " channels	18-25
" " " " special channels	26-33
Moment, shear and deflection of beams under various loadings	108-111
" with E-60 loading, at any distance from first wheel, to 300 feet	181-183
" with E-60 loading for spans to 130 feet	188-189
" " " " " deck plate girder spans, 30' to 130'	190
" " " " " truss spans, 60' to 270'	192
Moving loads on beams, diagrams and formulas	111
Natural trigonometric functions	154-159
Notes, explanatory as to material, billing, ordering, increasing areas	5, 6
Numbers; squares, square roots, circumferences, and circular areas	166-178
Nuts and bolts, dimensions	121
Nuts and bolts, weights	122
Nuts for pins	126
Overrun, allowable, in weights of plates	146
Parabola	211
Pins, bearing values	127
Pins, cotter	124
Pins, moment of resistance	128-129
Pins, nuts and pilots	126
Pipe, weights and dimensions	134-135
Plates, bearing; for standard I-beams and channels	8-25
" " values for rivets in	116-117
" overrun in weights	146
Polygon, reduction to equivalent triangle	147
Properties:	
angles	34-49
beams, standard I	8-17
bulb angles	50-53
channels, standard	18-25
channels, special	26-33
compound sections	64
H-columns	60-61

	PAGE
Properties:	
Tees	54-55
Zees	56-59
Proportions of minimum I-beams and channels	7
Quarter ordinate curve	212
Radii of gyration of two angles, back to back	103-105
Radius of gyration of compound sections	64
Rails, dimensions and weights	152
Reactions of beams; allowable reactions based on web strength	66-67
Reactions of continuous beams	198
Rectangles, moments of inertia	148-151
Rectangular plates, weights	140-145
Reduction of area for rivet holes	119
" " allowable uniform loads on beams laterally unsupported	65
Resisting moments of pins	128-129
" " " structural shapes—see Moments	
Rivet and bolt grips, in flanges of standard I-beams and channels ..	§-25
Rivet holes; reduction of area	119
Riveting, detail dimensions	114-115
Rivets:	
bearing and shearing values	116-117
clearances for machine riveting	114
conventional signs	115
dimensions of heads	113
in crimped angles	114
lengths, for various grips	112
maximum size allowable in angles	114
" " " " standard I-beams	8-17
" " " " " channels	18-25
shearing and bearing values	116-117
spacing	115
weights	113
Rocker nests	208
Roofing materials; weights	132
Round and square bars; areas, circumferences and weights	136-139
Round bars, upset screw ends	125
Safe loads—see Loads, allowable uniform	
Sections rolled—General List	4
Sectors, circular; area	162
Segments; areas	163-165
Separators, cast iron, for beams	118
Shear, deflection and moment for various loadings of beams	108-111

	PAGE
Shear:	
safe, for rivets	116-117
safe, for standard I-beams based on web strength	66-67
Sheared plates, tolerances in weight	146
Shearing values of rivets	116-117
Shears for deck girder spans	190
Shears in spans, due to E-60 loading	188-189
Shears in swing bridges, E-60 loading	199-203
Shears in truss spans, E-60 loading	193
Sheet metal gauges	123
Ship building bulb angles, dimensions and properties	50-53
Ship building channels—see Channels, special	
Slope of flanges for standard structural shapes	7
Solid of revolution; volume	147
Spacing of rivets	114-115
Spans, limiting, based on web strength of standard I-beams	66-67
Specific gravities and weights of various substances	130-131
Specifications, as to metal	5
Square and round bars, areas and weights	136-139
Square bars, upset screw ends	124
Squares and square roots of numbers	166-178
Stagger of rivets to maintain net section	115
Static loads on beams, diagrams and formulas	108-110
Steel centering for concrete arches; weight	196-197
Stresses, allowable unit:	
for bending in steel beams laterally unsupported	65
for columns, for various ratios of slenderness	106
for rivets in shear and bearing	116-117
Stresses in viaduct columns due to temperature changes	194
Swing bridges; bending moments and shears	199-203
Tangent distances, standard I-beams and channels	8-25
Tee bars, properties and dimensions	54-55
Temperature changes; stresses in viaduct columns	194
Threads of bolts, U. S. Standard	120
Tolerances in weights of rectangular plates, A.I.S.C. Code	146
Triangle, equivalent to a given polygon	147
Trigonometric functions, natural	154-159
Truss spans, bending moments, E-60 loading	192
Truss spans, shear, E-60 loading	193
Truss spans, single track through, weights	195
Unequal angles—see Angles	
Uniform loads, allowable—see Loads	
“ “ equivalent, E-60 loading	186-187

	PAGE
United States Standard threads	120
Universal plates, tolerances in weights	146
Upset screw ends for square and round bars	124-125
Variations for plates, allowable	146
" in profiles and weights	5-6
Viaduct columns; stresses due to temperature changes	194
Volume of a solid of revolution	147
Wall bearing plates for standard I-beams and channels	8-25
Washers; weights	133
Web buckling and shear in standard I-beams	66-67
Weights and specific gravities of various substances	130-131
Weights:	
angles	34-39
bearing plates	8-25
bolts, bolt heads and nuts	122
bulb angles	50-53
connection angles	8-25
flat rolled steel	140-145
girder spans, E-60 loading	190-191
H-columns	60
pin nuts and pilots	126
pipe	134-135
rails	152
rivets and rivet heads	113
roofing materials	132
round bars	136-139
special channels	26-33
square bars	136-139
standard I-beams	8-17
standard channels	18-25
steel centering for concrete arches	196-197
Tee bars	54-55
truss spans	195
various substances	130-131
washers	133
Zee bars	56-59
Weights, overrun for plates	146
Wheel determination for maximum concentration, E-60 loading	180
Wheel loads; stress calculation by influence lines	206-207
Wire gauges	123
Zee bars, dimensions and properties	56-59
Zones, circular; areas	162

