

## Box-Tube Connections; Choices of Joint Details and Their Influence on Costs



Jeffrey W. Post

### Author

Jeffrey W. Post is a welding engineer consultant serving the structural steel fabrication industry. He graduated from Ohio State University with a bachelor of science degree in welding engineering in 1966 and is a registered professional engineer in Ohio and Texas. He has been a fitter, boilermaker, certified welder, and certified welding inspector.

Mr. Post has been principally engaged with tubular structures for the offshore industry, including Shell Oil Company's 50,000 ton "Bullwinkle" drilling platform recently installed in 1,350 feet of water in the Gulf of Mexico. He prepares fabrication specifications including welding procedures and designs special welding and repair procedures which include non-destructive testing methods. Mr. Post served as vice president of manufacturing for a company that produced tubular leg assemblies for offshore jack-up rigs and dealt with fitting and welding of heavy-wall, high-strength, low-alloy tubulars welded to 100 ksi Q & T plates up to 6" thick. He was the division welding engineer for J. Ray McDermott, the world's major producer of offshore structures and a welding engineer for Chicago Bridge & Iron Company.

Currently, Mr. Post is chairman of the Subcommittee on Tubular Structures of AWS D1.1, Structural Welding Code-Steel and is an active member of a resource group of the American Petroleum Institute dealing with material, welding, and testing for the offshore platform industry.

### Summary

The choice of joint types and specific joint details have a significant cost impact on structures. This is especially true for those designed with square or rectangular structural steel tubing. Tubular connections are inherently welded, and since the bulk of the costs are in the connections, some things that can be done to reduce the costs of welded tubular connections will be given.

This paper is aimed at architects, designers, detailers, and fabricators with the emphasis on box tubing and on the many choices available with regard to connection geometry and joint details. It follows that these choices are not all equivalent in costs and the reasons why will be discussed.

A matrix of choices has been prepared to encourage those involved to consider all of the alternatives available. The choices to be discussed include: pipe versus square or rectangular tube; matched versus stepped box connections; gapped versus overlapping branch members; and the selection of joint details (i.e. complete joint penetration groove welds, partial joint penetration groove welds, or fillet welded connections). Appropriate inspection levels are also indicated.





00502

**Box-Tube Connections;  
Choices of Joint Details  
and Their Influence on Costs**

INTRODUCTION

The choice of joint types and specific joint details can have a significant cost impact on any structure. This is all the more true for structures designed with steel tubing. One of the first choices an architect or designer may make that influences further choices of joint types and joint details, is the choice between round tube or pipe versus square or rectangular tubing. For this discussion, structural tubing will be defined as the family of hollow shapes with square or rectangular cross sections collectively referred to as box tubing. Box tubing offers some unique benefits over round pipe or tube. Some of the economic logic of box-tube connections will be presented herein.

The cost is in the connections! This is hardly surprising to anyone involved with structural steel but, the selection of the connection details involves many choices and these choices can play a major role in the costs of a structure. Some of these choices may or may not be so obvious. The discussion that follows will show how or where these choices appear. The key words to watch for are "choose" and "choices". Table 1 illustrates the matrix of choices for box-tube connections. It shows that with the choices of joint types and their variations plotted against the choices of joint details, a multitude of possibilities exist. To choose, implies an opportunity to select freely from several possibilities but, the cost of each choice may not be equal.

So, how does a tubular structure evolve? First, there is a need. For this discussion, consider a tubular truss or space frame for example. Secondly, an architect may develop a grand concept choosing box tubes rather than round tubes to fill that need. Third, a structural designer may then analyze the truss or frame for loads and using the AISC Manual of Steel Construction<sup>(1)</sup>, choose the member sizes. At this level, joint types (butt, T-, Y-, etc.) are mainly determined by global design considerations. However, some choices initially occur here; for instance, matched or stepped connections with gapped or overlapping branch members. These terms will be defined and their significance relative to the cost of connections will be addressed.

Next, the designer may turn to AWS D1.1 Structural Welding Code<sup>(2)</sup> for specific joint detail categories. His choices are complete joint penetration (CJP) groove welds, partial joint penetration (PJP) groove welds and fillet welds. He may



further choose the specific joint details or leave them to a detailer or the fabricator. All the available choices are not equivalent in cost. Depending upon the choices made, these can cause significant cost increases or decreases relative to coping or miter cutting, fitting tolerances, welders' skill level, required accessibility for welding, and appropriate inspections and their associated ease or difficulties.

To help illustrate the choices available, as indicated by the matrix of Table 1, a series of box-tube mockups were produced using ASTM A500 structural steel tubing ranging in size from 1-1/2" to 5" and with wall thicknesses from 1/8" to 1/2". These mockups can be arranged in a variety of ways as shown by the figures herein to represent any of the AWS D1.1 prequalified details for box-tube connections in either the matched or stepped configuration with either gapped or overlapping branch members. Most of the 30 possible choices in the matrix have been shown in the accompanying Figures. A few cases were omitted for brevity. Gapped connections were not included in the matrix since multiple branch members can be considered independently as simple T- or Y-connections.

Tubular connections are a 3-dimensional phenomenon. As such, it is difficult to depict all of the necessary joint details in 2-dimensional sketches. Even photographs of mockups fail to portray all of the details involved. It is better to physically examine the mockups in person. These will be made available at the Kansas City Conference.

AISC designates box tubing as TS a x b x t, where "TS" is the group symbol for Tubular Section; "a" is the nominal major width; "b" is the nominal minor width; "t" is the nominal wall thickness. The terms used for box-tube connections follow those given in AWS D1.1 and some of them are given here in Figure 1. For a more detailed explanation of tubular terms and definitions, please refer to Section 10 of AWS D1.1, the Commentary to Section 10, and Appendix B of AWS D1.1.

#### DISCUSSION

Tubular connections are inherently welded in space frames and trusses (less so for beam and column building construction). Since a huge share of the cost of the structure is in the connections, let's consider where the costs come from and how better choices can lower the costs of welded tubular connections. Several choices have been identified in the Introduction. These will be defined and discussed in turn and relative cost comparisons will be given. No attempt has been made to apply any dollar amounts to these costs. Actual dollar numbers could be developed if all the factors are known for any given situation. Great



caution must be exercised here in order that fabricators inexperienced with box-tube connections or unknowing estimators don't introduce faulty or biased input into any cost comparison. To help in a cost comparison of CJP versus PJP details, it would be very useful to prepare an accurate mockup of both cases so everyone involved can readily see the difference in such things as bevel preparation, fit-up, accessibility, etc.

#### Round Versus Box Tubing

For architectural merits and simplicity of fabrication and inspection, box tubes provide advantages over round tubes that usually outweigh their drawbacks. For example, round tube or pipe offers a greater selection of sizes and material grades while box tubes have limited available sizes and grades without resorting to special order. Round tubes can readily accept branch members in any plane while box tubing offers simple welded connections only in orthogonal planes. When not in orthogonal planes, more complex connections can and have been devised for the branch members.

Where box tubes can be used in the orthogonal planes they offer several unique benefits over their round brethren. Box sections are easier to handle and stack. They are easily cut and mitered with bandsaws since no complex copes or saddle cuts are required, which occurs when a round tube intersects another round tube. If branch members overlap each other, compound miter-cut box-tube members can be slid sideways into place as shown in Figure 2. With round tubes, overlapping connections prevent some diagonal members from being installed as a single piece. For those cases, stubs or windows may be required to facilitate member installation. A detailed discussion of stubs and windows is given in Reference 3. Finally, box-tube members can easily accept backing material, a point that will be discussed further in the following sections.

#### Matched Versus Stepped

Matched-box connections are defined as a connection created by the intersection of two or more box-tube members that have a common outside dimension and arranged as shown in Figure 3 so that the sides of the branch members are flush with the sides of the chord or thru member. By contrast, a stepped-box connection occurs when at least one dimension of the branch member is smaller than the side to side dimension of the chord.

The significance of stepped versus matched-box connections occurs in several areas. First, following the AWS D1.1 prequalified details, the fillet weld categories can only apply to stepped-box connections where the width of the



branch member is less than or equal to 80% of the chord member width.

In matched connections, careful consideration must be given to wall thickness. For instance, a designer selects a TS 4 x 4 x 1/2" chord member to carry the design loads. Suppose some branch members are carrying small loads, so he selects TS 4 x 4 x 1/8". The inherent problem here is the corner radius or corner dimension of the chord member. The ASTM standard for A500 structural tubing limits the corner radius to three times the wall thickness of the tube. Therefore, the thicker the wall, the greater the corner radius. Most A500 tubing is produced by continuous forming and welding strips of steel into round tubing. After welding, it is drawn through dies to produce round tube or through additional sets of forming rolls to produce square or rectangular tube. When round tube is "squished" or formed into box sections, the resulting corner radii usually do not merge tangentially with the side walls. This trait of box tubes is more noticeable with greater wall thicknesses. Because the shape of the corner radius and its tangent point with the side wall is important in joint detailing, the AWS D1.1 Committee defined a "corner dimension" for the first time in the 1988 Code. The corner dimension is determined by placing a 90° square on the corner of a tube and measuring to the point of contact. The corner dimension is almost always less than the radius, as determined by a radius gauge. This proves to be beneficial when measuring root opening and groove angle.

Figure 4 depicts the significance of the corner dimension in matched box connections for the example cited. For comparison, without consideration for structural loading, the figure also shows the chord member replaced by a TS 4 x 4 x 1/8" member and the corner problem is mitigated. The mismatching wall thickness leads to more difficult welding on the side zones using either CJP or even PJP details due to the large corner dimension. There are however two good alternative solutions for the example given. The most obvious solution would be to reduce the size of the branch member since it is so lightly loaded. For example, a TS 3 x 3 x 3/16" might carry the same load while providing a stepped box connection suitable for fillet, PJP, or CJP weld details. The other solution is to cut a backing plug as shown in Figure 4. This plug can serve several functions. It provides backing for welding and the plug provides for variation in fit-up tolerances in both the CJP and PJP cases. This is especially helpful for field welds. For some erection sequences, the plugs can be shop installed on the chord members which facilitates rapid and precise positioning in the field. The significance of backing for welding of tubular connections must not be overlooked and more discussion about backing will occur in the sub-sections about CJP welds.



Sometimes designers will select a common tube size for a truss for aesthetic reasons where only variations in the wall thickness occur. There is however another hidden benefit in choosing stepped box connections over matched box connections when aesthetics are important. With matched box connections using either CJP or PJP details, it is difficult to produce flat appearing welds in the side zones without a lot of costly cosmetic grinding. This problem does not exist with stepped box connections. With stepped box connections there is a natural ledge to support the weld beads. Even the CJP and PJP, with their required weld grooves, have a natural contouring fillet that requires very little grinding, if any, for cosmetic reasons. The one drawback to stepped connections is the inherently lower strength of the flat face of the chord member as determined by yield line analysis. See Reference 4 for further design guidance.

#### Gapped Versus Overlapped

A gapped connection is one in which two or more branch members intersect a common chord member with some nominal space between the branch members as shown in Figure 5. By contrast, an overlapped connection occurs when two or more branch members intersect each other. Gapped or overlapped connections can occur in both matched or stepped-box connections. The significance of these variations is that the gapped connections are always easier to fit with better access for welding while the overlapped connections usually require compound copes or miters and provide no flexibility as to member installation sequence. With gapped connections (usually a 2" nominal gap) the branch member can be moved slightly about its work point to improve the overall fit-up and root openings. This luxury does not exist with the overlapped connections. One significant drawback to gapped connections is that all branch member loads must pass into the chord. This may require heavier chords. Conversely, the overlapped branches may pass some or all of their loads directly to each other without affecting the chord member.

#### CJP Groove Welds

CJP groove welds are the joint detail category most frequently selected, but not usually the most economical one. Often CJP groove welds are selected by default. That is, no detailed consideration is given to them. It is generally felt that CJP groove welds must be better than PJP groove welds (in fatigue loading situations, this is true). Consequently, engineers or designers choose CJP's even for cases not driven by fatigue. Granted, CJP's using the AWS prequalified details will develop the full strength capacity of the connection but, PJP groove welds using E7018 or E71T-X weld metals on ASTM A500 tubing will also develop the full strength of the connections in most cases. The problem



here is that the AWS D1.1 Code may require the designer to do some additional strength checks. Even on smaller projects, the costs of gearing up for CJP's (e.g. 6GR tests) will exceed the extra engineering costs, if any.

CJP groove welds for tubular connections, whether round or box, implies open root conditions and requires more precision in fitting the members and the highest welder skill levels. In order to achieve complete joint penetration from one side without backing, the AWS D1.1 Structural Welding Code requires that the open root dimensions must be closely controlled and the minimum groove angles must be assured. Also, the welders must be capable of this most difficult welding and demonstrate their skills by passing the 6GR open root welder test plus the special corner welding test.

One interesting aspect of box tubes with their flat sides is their ability to accept backing rings or plugs. With appropriate backing, the open root difficulties vanish. The welder qualification requirements drop back to the easier 3G plus 4G requirements. Also, a greater variation in fit-up can be tolerated without unduly affecting welding quality. The AWS D1.1 Code requires continuous backing whenever backing is to be used. Some fabricators choose to form bar stock to fit the inside of the tube. However, any butt splices in the bars must be welded 100% to prevent crack initiation from any unwelded butt splice in the backing ring or bar. In a few unique cases, a smaller size box tube can be found and cut into appropriate rings. Designers and fabricators should consider this option if possible as it is the least expensive way to provide continuous backing. For instance, a TS 3-1/2 x 3-1/2 x 1/4" will fit snugly into a TS 4 x 4 x 1/4" member with minor grinding to remove the ID weld flash from the 4" member. Alternately, the backing ring would fit loosely into a TS 4 x 4 x 3/16" and much too loose into a TS 4 x 4 x 1/8" member. Some fabricators cut plugs with a photoelectric tracing head and machine cutting torches. This provides one-piece backing without the need for 100% butt welds. As suggested in the AISC Proceedings from the Nashville Conference<sup>(3)</sup>, these plugs may be solid or cut hollow. It was further suggested that such plugs could be cut on a bias with a beveling head attachment added to the machine cutting torch to produce branch member backing for other than just the 90° T-connection cases. Examples of various types of backing are shown in Figure 6.

Miter cutting of branch members can be done with saw cuts followed by torch beveling and grinding or grinding alone to produce the required weld groove angles. Careful grinding is also required to provide smooth transitions from one groove detail to the next that always occur at the four corners of each branch member.



Designers that over-specify CJP groove weld details for box-tube connections are likely to be the same ones that over-specify inspection requirements too. They will require 100% Ultrasonic Testing (UT) of each connection. Obviously, there are critical cases where the higher level of inspection is warranted, but depending upon the skill and experience of the UT technician, this inspection technique often leads to a contest to see which side possesses the greater urinary-tract bladder pressure!

Ultrasonic testing can and has been used successfully on tubular connections. However, careful consideration must be given to such factors as wall thickness, joint geometry, discounting the geometry problems of the corners, and technician skill and experience with tubular connections. Mockups or sample connections with known defects must be prepared from box tubes to assist in technician training and evaluation prior to his inspection of the production work. Further, visual confirmation of UT indications should be required. This is best achieved by forming an excavation party consisting of a craftsman to perform arc gouging and grinding, the fabricator's quality control representative (or sometimes a foreman), the UT technician, and the owner's inspector or representative. Thin layers of metal are progressively removed to reveal the UT indication. As the predicted indication depth is approached, all members present should be given an opportunity to observe the progress prior to removing the next layer. Observed indications which exceed the acceptance standards are then rejected by visual confirmation. Weld repairs are then made and those repairs are again UT examined.

For the CJP box-tube connections, more inspection effort should be placed on inspection of the fit-ups prior to welding. In this way, the proper root openings and groove angles can be verified. Without good control of fit-ups, even the best welder will have difficulty producing CJP groove welds of the expected quality. It is better to put your inspection effort up front and follow-up with a good visual inspection and possibly some random or spot checking with UT than to do all inspections after welding. The fit-up inspection seldom leads to controversy because the root opening and groove angles are easily measured and verified. Then with qualified and trained welders a high success rate can be assured.

#### PJP Groove Welds

PJP groove weld details for box-tube connections can offer significant cost savings in several areas; groove bevel preparation, fitting, welder skill levels, and inspection. In preparing a branch member to fit into a truss for instance, the miter cutting would be the same for either the CJP or the PJP groove weld case. The next step is to



prepare the necessary bevel angles to comply with the prequalified groove details. The PJP groove angles required are much less demanding and the differences are most notable in the heel zone where the local dihedral angle  $\Psi$  is in the range of  $30^\circ - 60^\circ$ . In this range the CJP details require a full-bevel preparation that is at least one-half of the local dihedral angle. In a common  $45^\circ$  case for instance, the bevel preparation angle is  $22\frac{1}{2}^\circ$  which leaves a fairly thin and sharp bevel. In the worse case of  $\Psi = 30^\circ$ , the bevel preparation is a  $15^\circ$  sliver of metal that is very difficult to produce and is easily melted away when trying to make a good root-pass. For the PJP case on the otherhand, the heel zone for any  $\Psi$  in the range of  $30^\circ - 60^\circ$  requires no bevel preparation beyond the natural groove formed by the intersecting members with only a miter cut. Of course, the side zone and the toe zone may require some bevel preparation, but none with the very thin and pointed bevels as found in the heel zone of the CJP cases.

In the area of fit-up, whether done in the shop or the field, the PJP groove weld details offer still more advantages over their CJP counterparts. As previously stated, the AWS D1.1 prequalified details require close controls on groove angle and minimum-to-maximum root openings in order for the highest skilled welders to achieve complete joint penetration from one side without backing. With the PJP's, there is a maximum of  $3/16$ " on the root opening, but the minimum is zero. This means that the steel may be brought into tight contact, which is the easiest case to fit-up. Further, PJP groove welded box connections could be fit with similar backing material as discussed in the previous section. This would aid in fit-up and alignment tolerances, especially for tie-ins or field erection situations. Such cases would fall outside of the prequalified limits when the root opening exceeds  $3/16$ ", but with backing, such modified details would be easy to qualify with mockups or sample joints. These cases of PJP's with backing are also included in the matrix of Table 1.

The welder skill level required to execute PJP groove welded connections is lower than that for the CJP cases. This does not imply that inferior welds will result but, higher skill and experience are required to handle any open root joints welded from one side. For the PJP's, only the standard 3G plus 4G plate tests are required to weld in all positions. This implies that if the work could be positioned, the more difficult overhead test requirements would be eliminated. Finding or training welders for the conventional 3G plus 4G qualification test is relatively easy. Most fabrication shops and field sites have or can obtain such personnel. On the other hand, finding or training welders to pass a 6GR open-root test is more difficult. Along United States coastal areas where fabricators have been building offshore platforms, experienced welders and instructors have evolved



to handle the 6GR test. Away from these regions fabricators can count on a lengthy training period to develop their own 6GR qualified welders. This can result in a big surprise in costs, as delays in acquiring adequate 6GR welders occur at the startup of a project. Also, simply passing a 6GR test does not guarantee that a welder can successfully weld all open-root cases he may encounter. That takes additional experience. In the meantime, weld repair costs could skyrocket. It is clearly better to use PJP's or CJP's with backing wherever practicable and avoid any difficulties with welding open-root conditions.

Finally, inspection requirements for PJP groove weld connections are less prone to uncontrollable costs. PJP's are seldom suitable for ultrasonic examination. PJP's, like all AWS D1.1 welds, require 100% visual examination. Sometimes Magnetic Particle Inspection may be added for certain connections, but for more critical connections an inspection of the fit-up should be required. Ultrasonic should be reserved for only the most critical cases and then only when a qualified technician with tubular connection experience can be obtained.

Fillet-Welded Connections

Fillet-welded box connections are usually easiest to produce and therefore the lowest cost from a fabrication standpoint. The prequalified detail requirements of AWS D1.1 are the least onerous for fillets. They are applicable to any stepped-box connection provided the branch member width is less than or equal to 80% of the chord member width. Regardless of this requirement, the branch member and the fillet weld must be kept on the flat face of the chord member. This could be a problem with thicker chord members that may have a larger corner radius, but the corner dimension governs since it is usually less than the corner radius. In any event, this detail should be checked out prior to fabrication.

End preparation of branch members for fillet-welded connections are typically simple miter cuts usually produced with bandsaws. Saw cuts produce better fit-ups without a lot of grinding as with torch cut miters. Torch beveling and grinding is required only in the toe zone where  $\Psi$  exceeds  $120^\circ$ . This is to accommodate the required fillet leg size and is easily achieved.

The prequalified fillet details are permitted down to  $30^\circ$  brace intersection angle or  $\Psi$  as measured in the heel zone. This covers the vast majority of structural cases. The root opening may vary from 0 to  $3/16$ " maximum provided that the fillet size is increased by the amount that the root opening exceeds  $1/16$ ".



Welder skill requirements are the lowest for the fillet-welded connections. For all position welding, only the simple 3F plus 4F fillet weld tests are required for welders unless the angle in the heel zone is less than 60°. For these cases, only a 3G plus 4G plate groove test is required, which are common welder qualifications. As with the previous case where work can be positioned, the necessity of qualifying welders to weld overhead disappears. In either case, it is easier to find or train qualified welders for the fillet connection with 3F-plus-4F or 3G-plus-4G skill levels than the more difficult 6GR-plus-corner tests now required by AWS D1.1 for CJP box-tube welding.

Inspection of fillet-welded connections should generally be limited to visual inspection. Occasionally, spot checking with Magnetic Particle may be warranted. Inspectors can determine that the fillet weld is of the required size and possessing a good visual workmanship appearance. What cannot be determined after welding is the possibility of excessive root openings that would require increasing the fillet weld leg size. For this reason, the inspector should check fit-ups prior to welding.

#### CONCLUSIONS

1. Choose box sections over round sections for simple trusses or space frames for ease of fabrication.
2. Choose gapped connections instead of overlapping connections wherever possible for ease of installation of members and welding accessibility.
3. Choose stepped over matched connections for aesthetic applications to reduce the amount of cosmetic grinding.
4. Choose fillet welded connections wherever possible as the least costly to fabricate. Choose PJP groove welded connections over CJP groove welded connections for lower costs in bevel preparation, fit-up, welder skill level, and inspection.
5. Choose backing in CJP or PJP groove welded connections wherever practicable to reduce welder skill level requirements and improve welder's success rate.
6. Don't over-specify inspection requirements.
7. If you get stuck with doing open root CJP's, be sure to include 6GR qualification costs and, if UT is specified, insist upon visual confirmation by an excavation party.



ACKNOWLEDGEMENTS

Box tubing material was provided by Welded Tube Company of America, Chicago, Illinois and Standard Welding & Steel Products, Inc., Medina, Ohio. Brown Services of Humble, Texas permitted the author to use their fabrication shop facilities to produce the mockups shown herein.

REFERENCES

1. Manual of Steel Construction, AISC (ASD) 9th Edition.
2. Structural Welding Code - Steel, ANSI/AWS D1.1-88.
3. "Gaining Confidence with the Fabrication, Welding, and Inspection of Tubular Connections," J. W. Post, Proceedings of the AISC National Steel Construction Conference, June, 1989.
4. "Designing Tubular Connections with AWS D1.1," P. W. Marshall, Welding Journal, March, 1989.



# TABLE 1. Box-Tube Connection Choices

JOINT CATEGORY		GROOVE CATEGORY				FILLET
		CJP*		PJP**		
		Open Root	Backing	Tight Root	Backing***	
BUTT		■ <sub>1</sub>	■ <sub>2</sub>	■ <sub>3</sub>		
T -	Matched	■ <sub>4</sub>	■ <sub>5</sub>	■ <sub>6</sub>	■	
	Stepped	■ <sub>8</sub>	■ <sub>9</sub>	■ <sub>10</sub>	■	■ <sub>12</sub>
Y -	Matched	■ <sub>13</sub>	■	■ <sub>15</sub>	■ <sub>16</sub>	
	Stepped	■ <sub>17</sub>	■	■ <sub>19</sub>	■ <sub>20</sub>	■ <sub>21</sub>
Overlapping & Combination Connections	Matched	■ <sub>22</sub>	■	■ <sub>24</sub>	■ <sub>25</sub>	
	Stepped	■ <sub>26</sub>	■ <sub>27</sub>	■ <sub>28</sub>	■	■ <sub>30</sub>

\* CJP = Complete Joint Penetration Groove Welds

\*\* PJP = Partial Joint Penetration Groove Weld

\*\*\* PJP's with backing for variable fit-up conditions

Numbers refer to connection types presented as key #'s in the following figures.



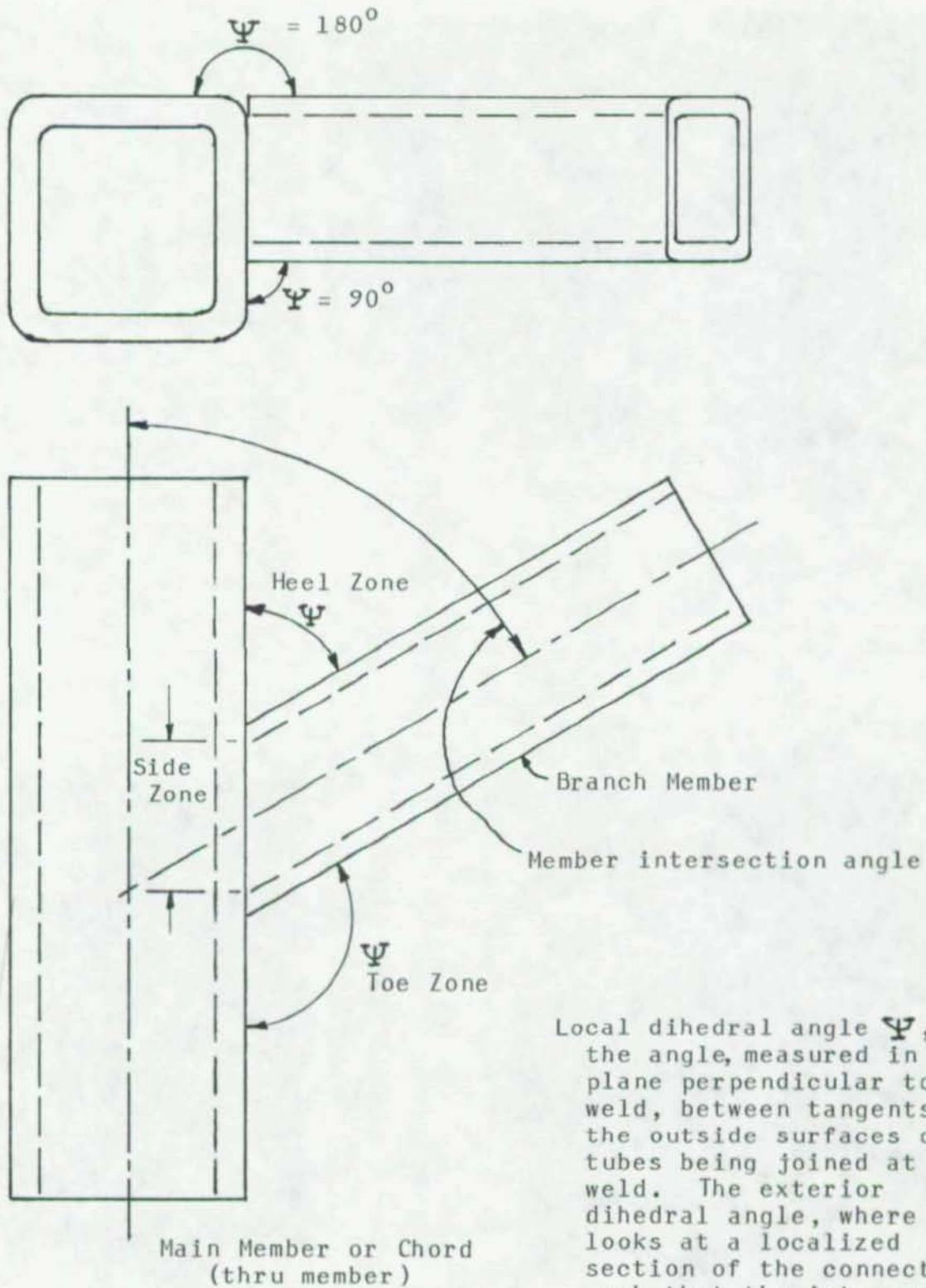
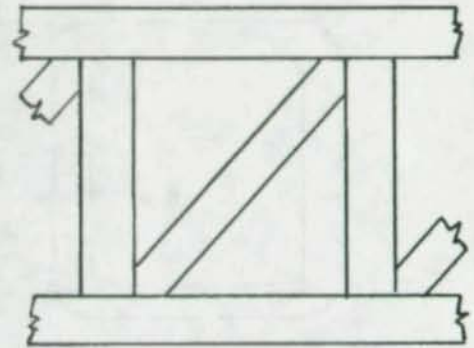
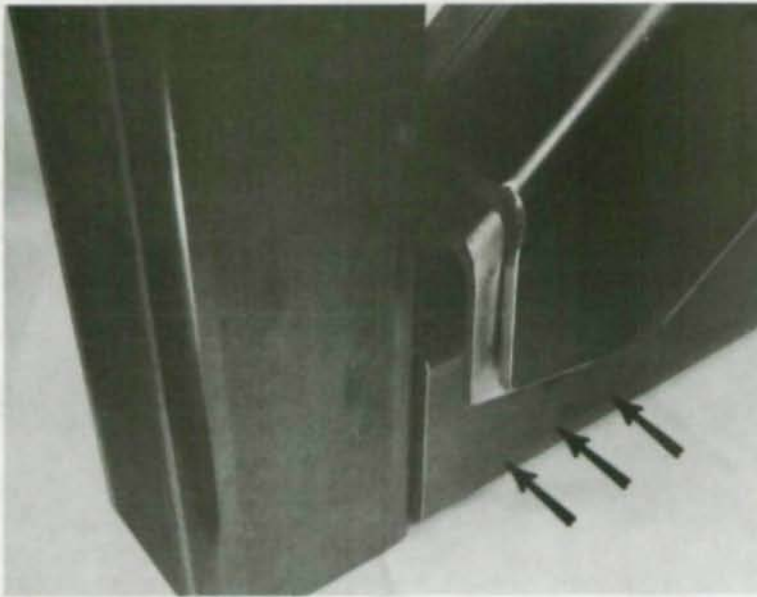


Figure 1. Definitions and terminology for box-tube connections.



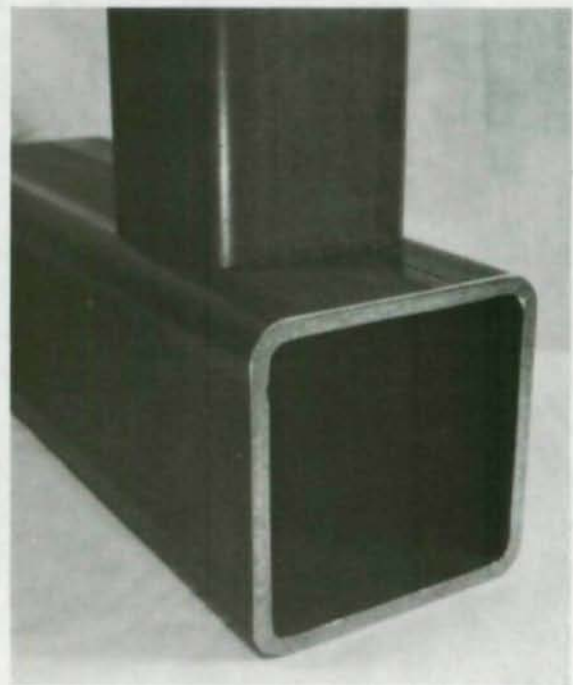


Diagonal member can slide into position. This is not possible with round tubes with similar diameters.

Figure 2. Overlapping branch member (with loose backing for flexibility in fitup) sliding into position.



Matched



Stepped

Figure 3. Matched versus stepped-box connections.



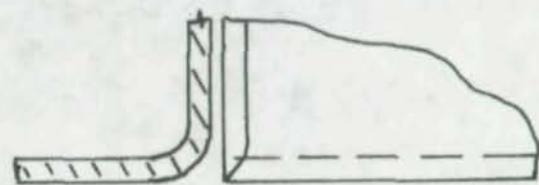
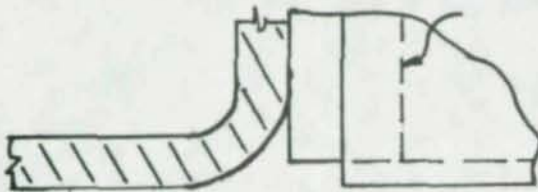
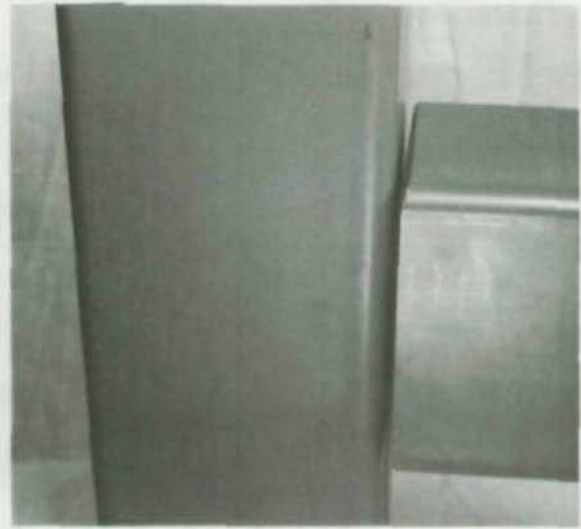
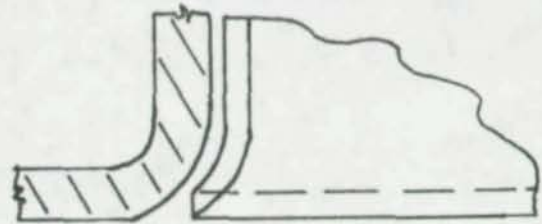
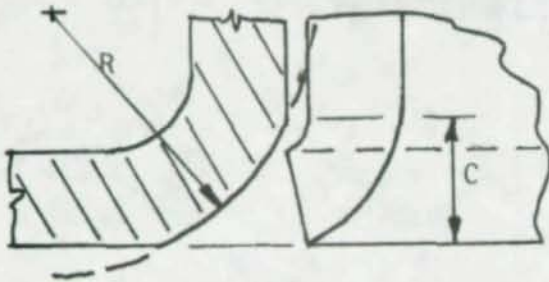
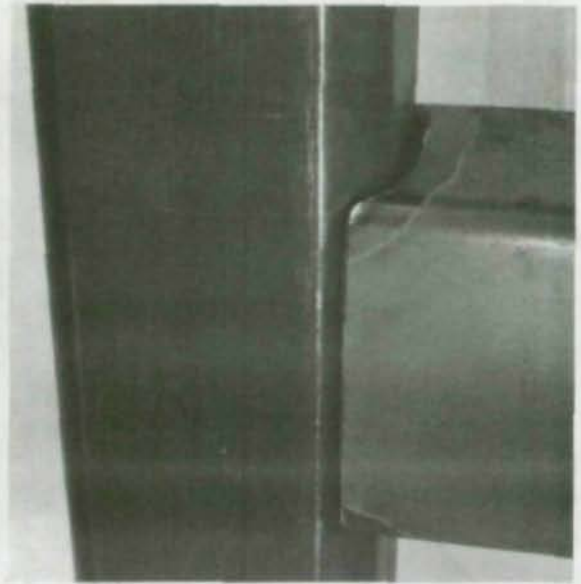
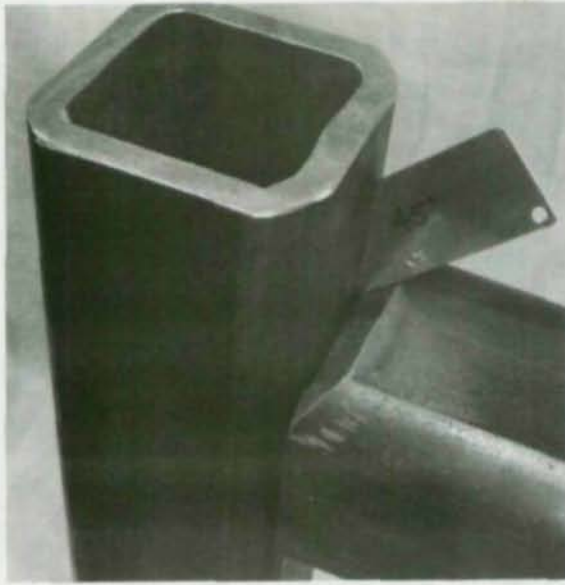
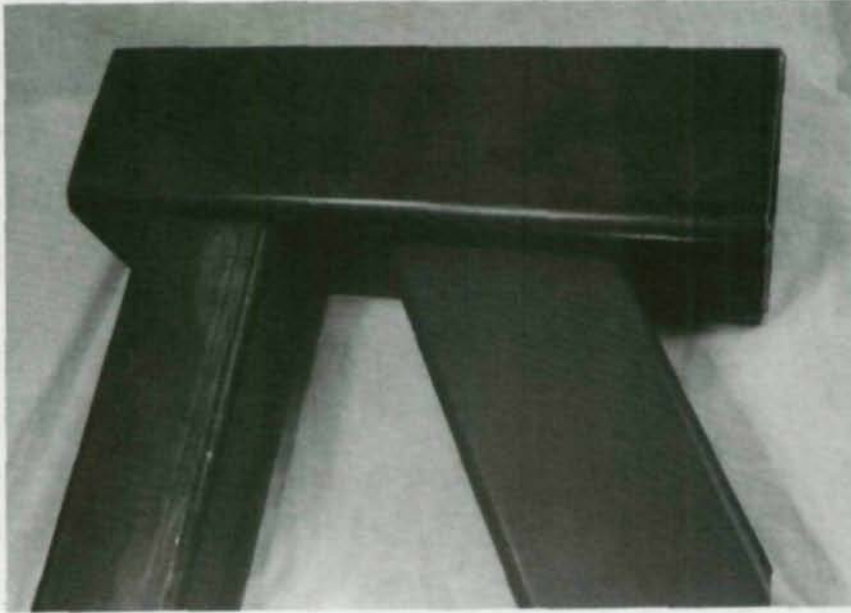


Figure 4. Corner dimension (radius) of box tubes.  
Sections drawn full size for TS 4x4 square tube.



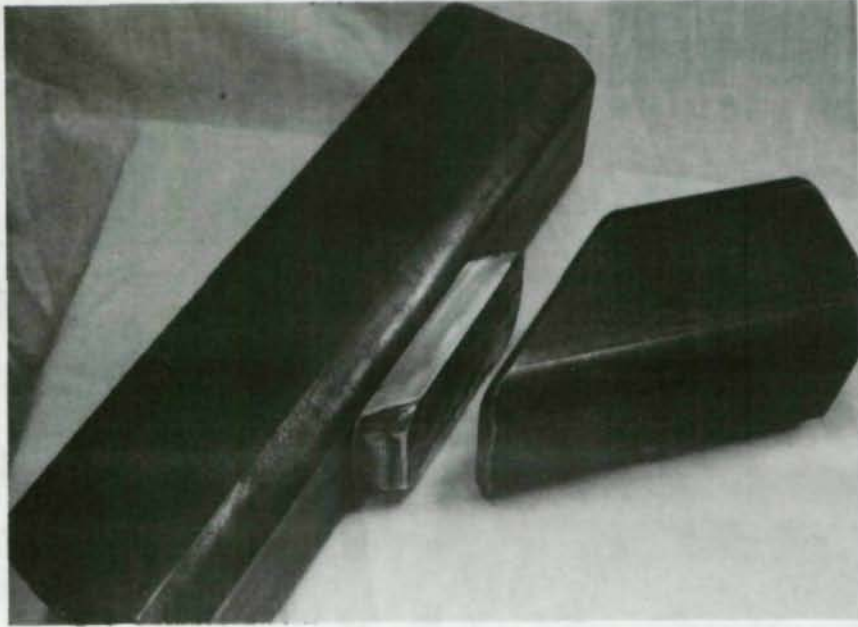


2" nominal gap



Figure 5. Gapped versus overlapped stepped-box connections. This can also occur with matched-box connections.



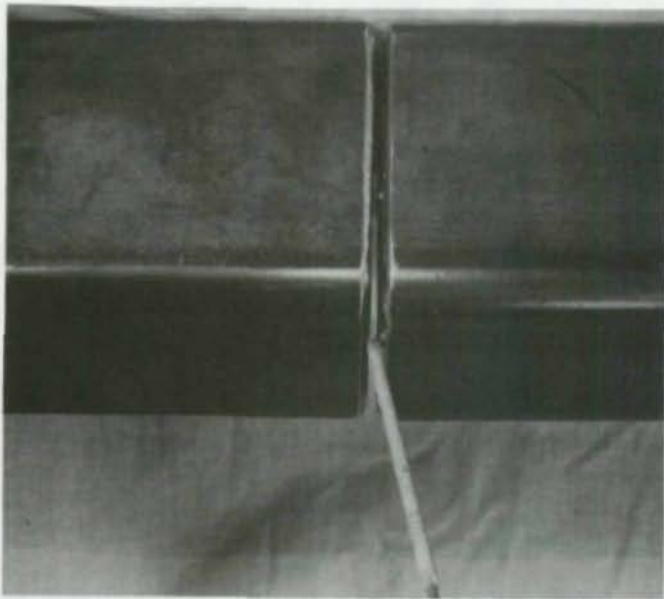


45° bias-cut backing plug.

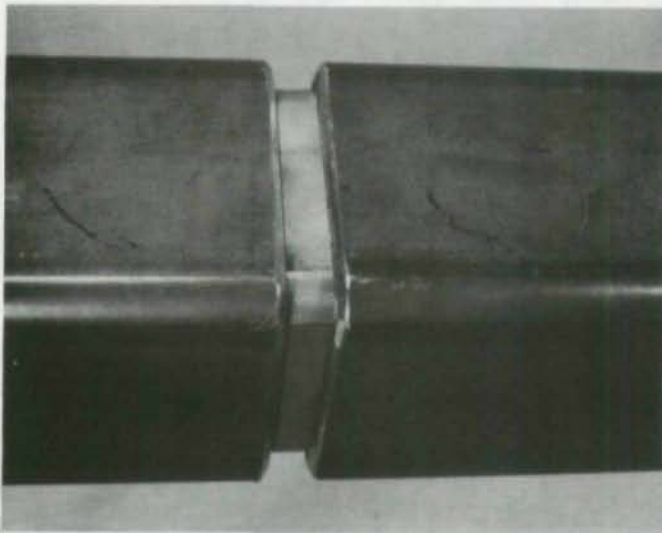
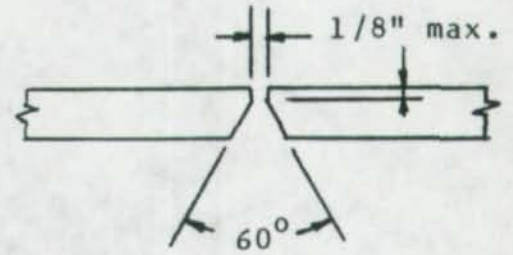


Figure 6. Examples of steel backing styles: solid plug, hollow plug, bias-cut plug, and two examples of compound miter-cut box tubing.

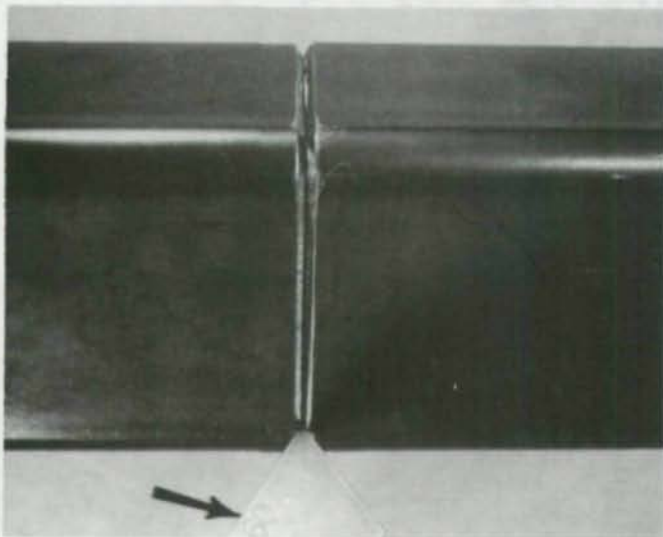
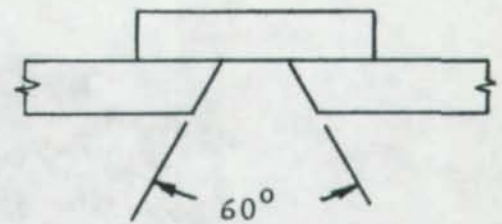




CJP open root (Key 1).  
3/32" electrode shown.



CJP with backing (Key 2).



PJP, tight root (Key 3).

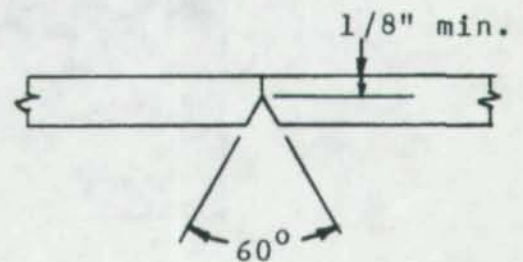


Figure 7. Butt joints.





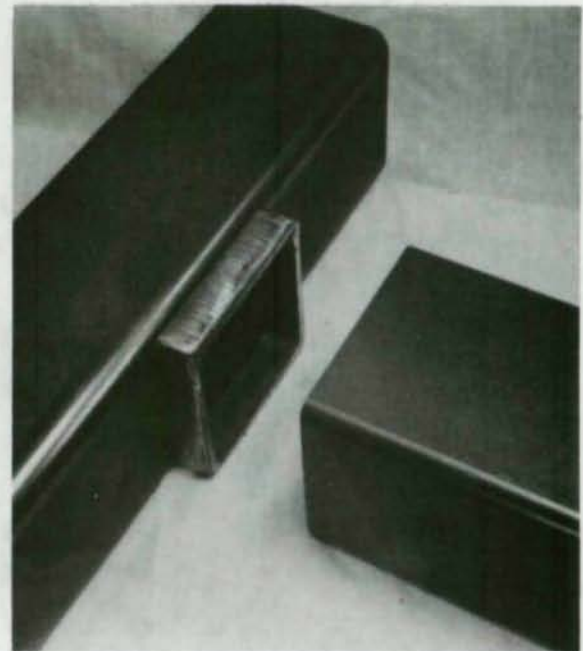
CJP (Key 4).  
TS 4x4x $\frac{1}{2}$ " with 1/8" electrode.



CJP with backing (Key 5).  
TS 4x4x1/8" onto TS 4x4x $\frac{1}{2}$ ".

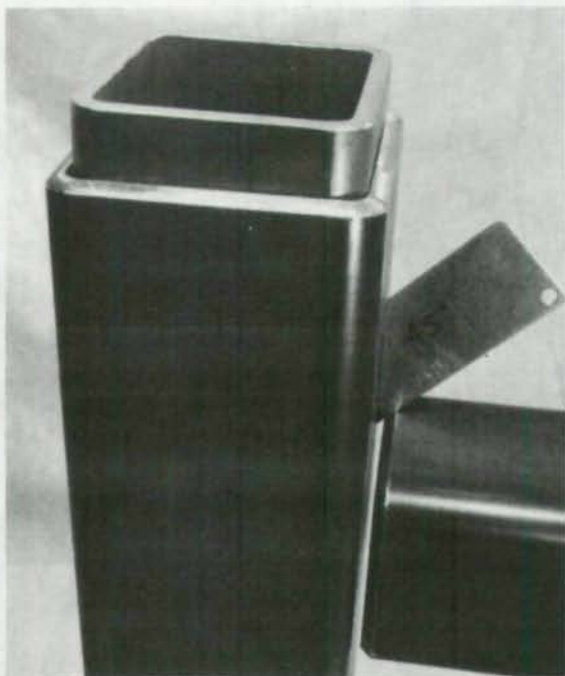


PJP (Key 6).  
TS 4x4x $\frac{1}{4}$ ".



Hollow-ring backing, pre-  
positioned onto chord member.

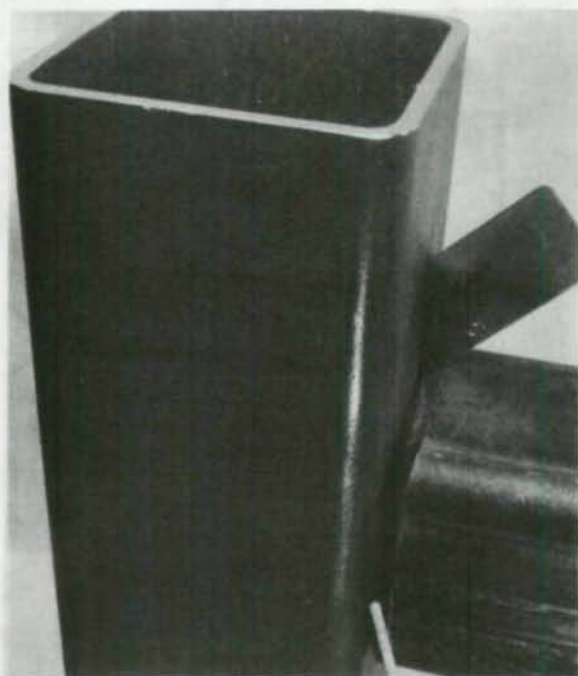
Figure 8. Matched T-connections.



CJP (Key 8).  $3/32$ " root opening with  $45^\circ$  groove.



CJP with backing (Key 9).



PJP (Key 10).  $3/32$ " electrode shown.



Fillet (Key 12).

Figure 9. Stepped T-connections.





CJP (Key 13).  
 TS 4x4x $\frac{1}{4}$ " with backing ring  
 for future butt splice.  
 TS 4x4x $\frac{1}{4}$ " branch member @ 45°  
 intersection angle. Required  
 bevel in heel zone is 22 $\frac{1}{2}$ <sup>0</sup> min.

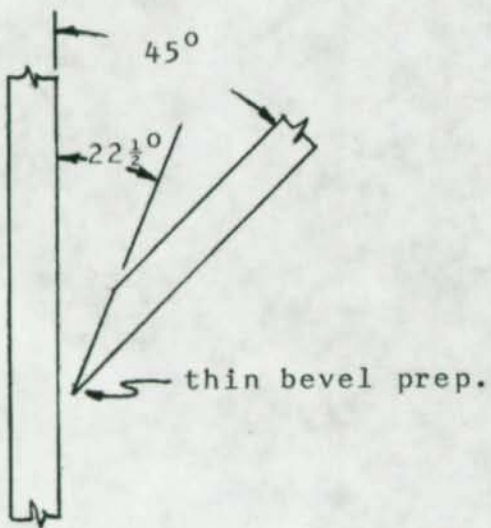


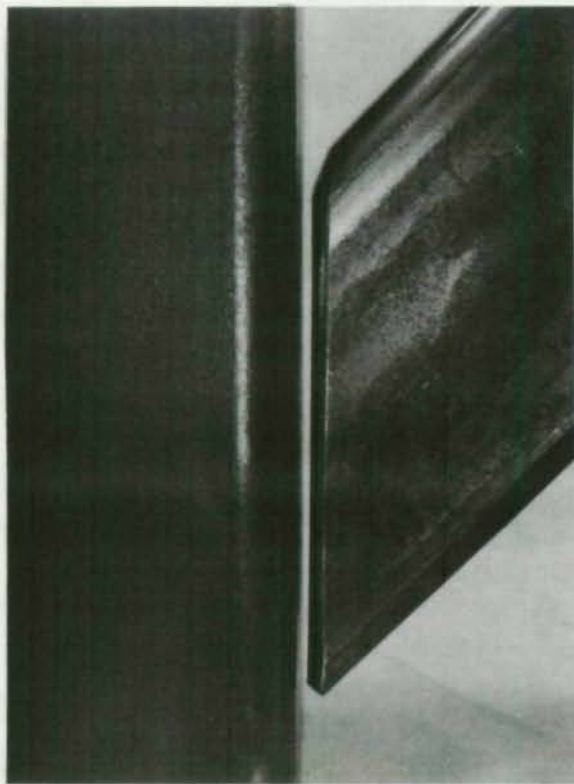
Figure 10. Matched  
 Y-connections.



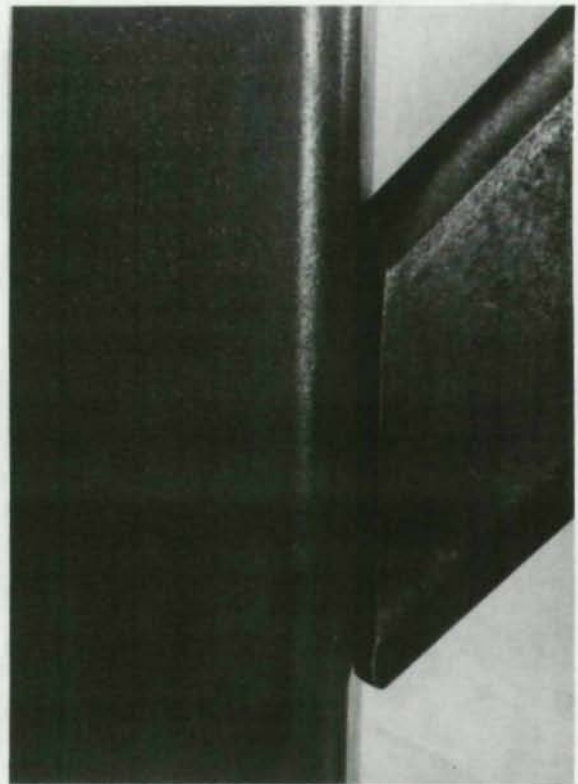
PJP (Key 15).



PJP with backing (Key 16).



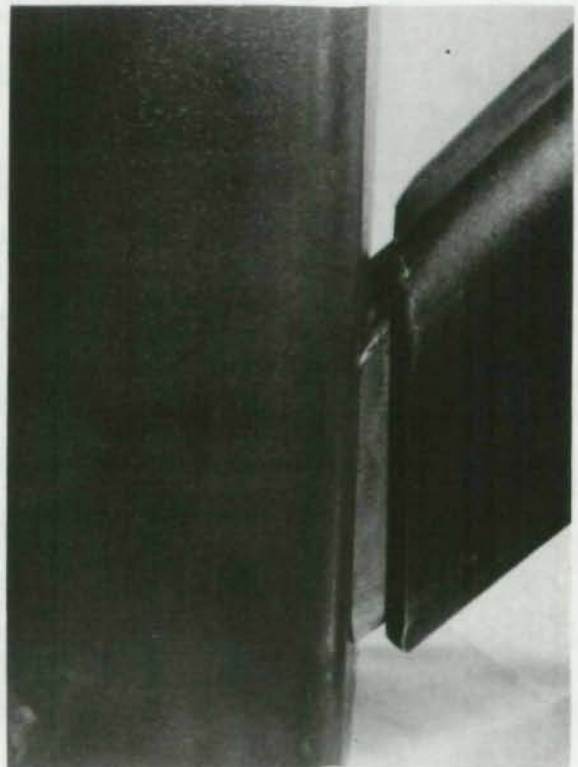
CJP (Key 17).



PJP (Key 19). Natural groove formed in heel zone.



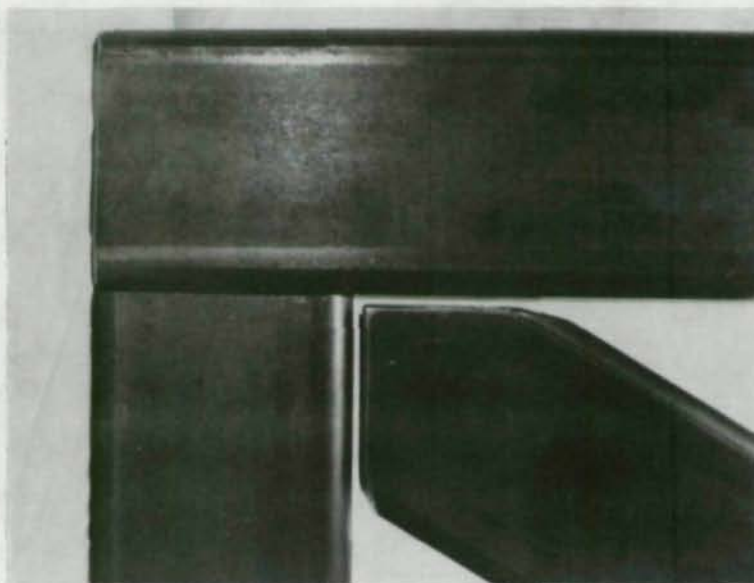
Fillet (Key 21). Note bevel in toe zone only.



PJP with backing (Key 20).

Figure 11. Stepped Y-connections.





CJP (Key 22).



PJP (Key 24).



PJP with backing (Key 25).

Figure 12. Matched, overlapping T-, & Y-connections.



CJP (Key 26).



CJP (Key 27).



PJP (Key 28).



Fillet (Key 30).

Figure 13. Stepped, overlapping T-, & Y-connections.