



1996 PRIZE BRIDGE AWARD: MOVABLE SPAN 8TH STREET BRIDGE OVER THE SHEBOYGAN RIVER



BY INCORPORATING THREE MAJOR INNOVATIONS, the 8th Street Bridge over the Sheboygan River in Sheboygan, WI, has redefined state-of-the-art for bascule bridge design. Most noteworthy of the innovations is that the bascule leaf is unbalanced and there is no counterweight or associated pit. Also, the roadway deck is a cast-in-place concrete slab composite with the steel framing below. And finally, the structural framing is remarkably simple in design. So innovative is the design that it was awarded a patent (Patent No. 5454127) by the U.S. Patent Office.

UNBALANCED BASCULE LEAF

AN UNFORTUNATE CHARACTERISTIC OF CONVENTIONAL BASCULE BRIDGE TECHNOLOGY is the large volume of space required in a pit below the roadway to accommodate the counterweight as it swings downward through an arc of travel when the bridge is raised. The counterweight and the pit, which is usually below water level, represent a significant part of the cost of construction. In addition, the pit is difficult to maintain.

For the 8th Street Bridge, the counterweight and associated pit were eliminated from the design. While this increased the force and power required to raise the bascule leaf, the demands on the machinery can be easily accommodated by modern hydraulic bridge drive systems. A life-cycle cost analysis showed that the savings in construction cost would more than compensate for the increased machinery and energy costs.

An additional benefit to the unbalanced design at the Sheboygan location was that elimination of the counterweight pit—and the resulting major reduction in excavation in the river bed—minimized the environmental impact at a U.S. EPA Superfund site.

ROADWAY DECK SLAB

BASCULE BRIDGES GENERALLY UTILIZE STEEL GRATING OR STEEL PLATES as the roadway deck. However, steel grating provides a rough roadway surface and allows slat-laden drippings to pass through, which has an undesirable environmental effect on the land and water below and also greatly accelerates the deterioration of structural elements below the grating. And steel plate roadway decks are expensive to install and require a complex, specially bonded wearing surface when used on bascule bridges.

The Sheboygan bridge uses a conventional cast-in-place lightweight concrete roadway slab designed to be composite with the supporting steel framing. This deck design greatly reduces costs and should result in a far more durable structure. The additional weight of the concrete deck can be accommodated by the bridge drive system that was used on the structure.

Special analyses were performed to assess stresses in the deck as the bascule leaf is raised, changing from an end-supported to a cantilevered condition. To improve deck durability, the deck concrete was poured with the leaf held in the cantilevered position: An effective "prestress" is developed in the concrete when the span is lowered to its end-supported position.

STRUCTURAL FRAMING

THE KEY TO THE STRUCTURE OF THE 8TH STREET BRIDGE is a massive cylindrical cross girder, about 5' in diameter, that runs across the full width of the bridge under the roadway deck, near the hinged end of the structure. It serves as the rigid spine on which all other primary structural components of the bridge are mounted.

The main longitudinal girders, one on each side of the bridge, are fastened rigidly to the cross girder. Also mounted rigidly on the cross girder are four pairs of "crank plates", which support the cylindrical cross girder and, when acted upon by the hydraulic pistons, impart torque to the girder to lift the bridge.

All support reactions and bridge-raising machinery forces are applied on the cylindrical girder, not the longitudinal girders. The inherent rigidity of the cross girder holds all bearings in proper alignment, regardless of the flex-

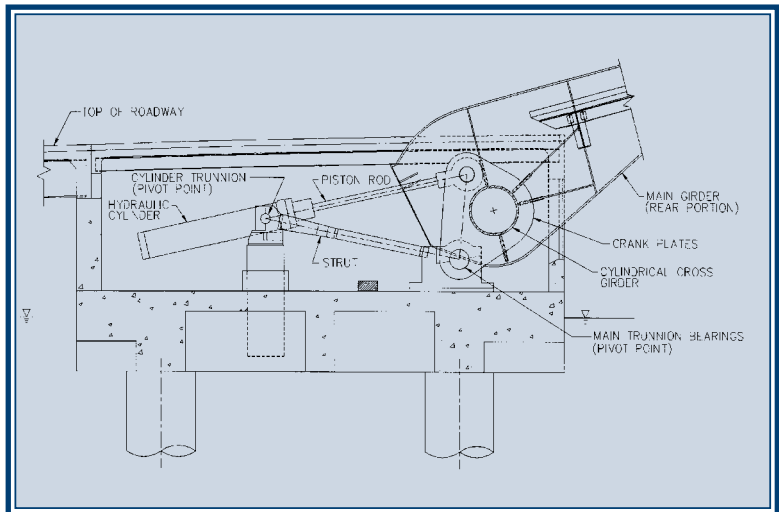

Judges Comments:

"An innovative operating system coupled with a beautiful design and appearance"

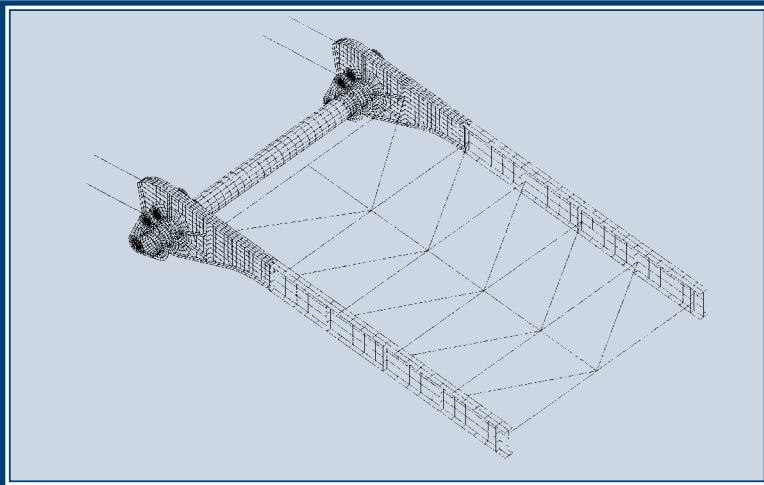

ibility of the longitudinal girders. Since there are no bearings mounted on the longitudinal girders, they need not be particularly stiff. Longitudinal girders of I section can be used—the greater torsional and lateral stiffness of a box section, as used in other bridges, is not required.

The use of I-section girders instead of the customary boxes results in major savings in construction cost. The I-sections also are more convenient to inspect, maintain and paint.

The project was completed on schedule, just 18 months after the start of construction, and within the original budget established by the owner, demonstrating that innovation in bridge engineering is not necessarily a risk.

Project Team

Designer:
Teng & Associates, Inc.
Chicago

General Contractor:
Lunda Construction Co.

Fabricator:
PDM Bridge
Eau Claire, WI

Erector :
Hi-Boom Erecting Inc.
Black River Falls, WI

Owner:
Wisconsin Department of
Transportation (District 3)

Project Data

**Steel
wt./sq. ft.
of deck:**
40 lbs.

Cost:
\$7.3 million

**Steel
tonnage:**
390

**Please note
that red text
denotes an
AISC member*