

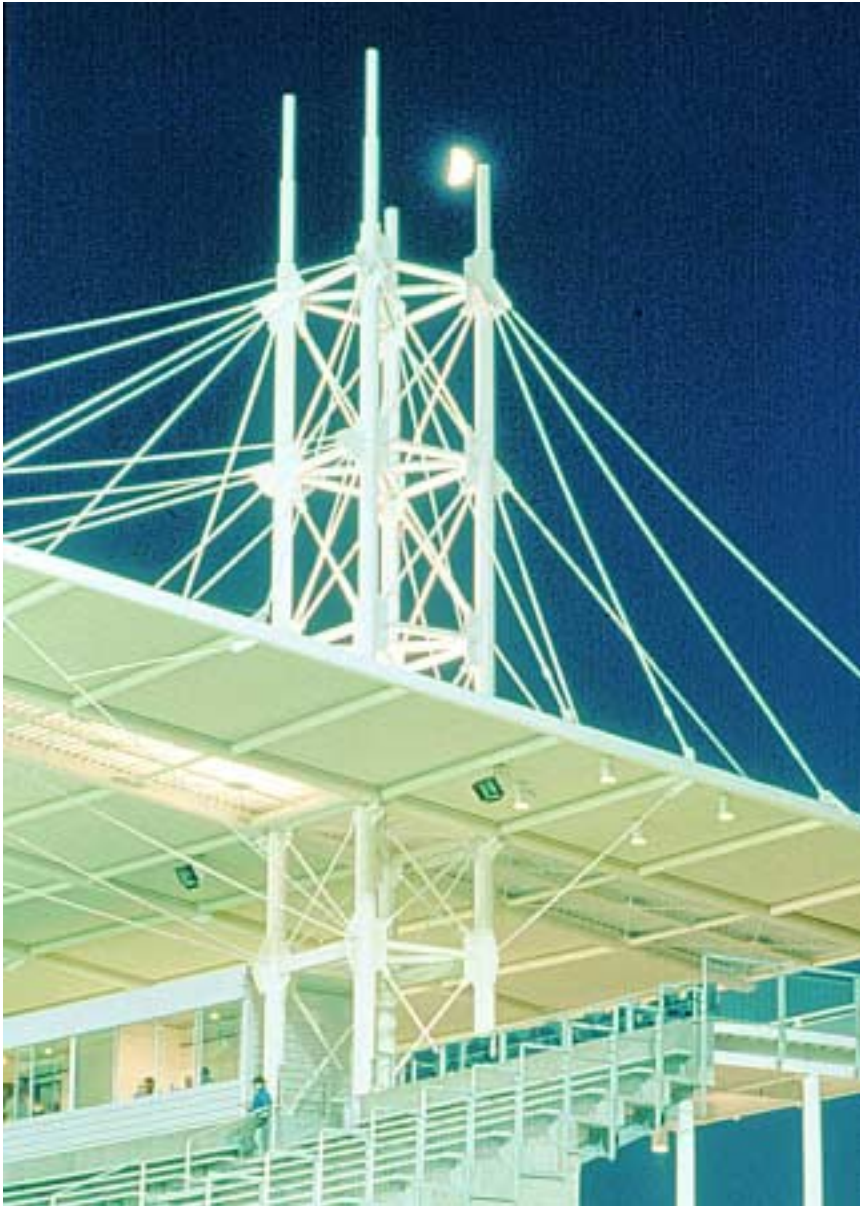

# Hillsboro Stadium

*Hillsboro, Oregon*



**T**he success of the Hillsboro Stadium project was based on the design team's ability to be creative in its response to the owner's (The Hillsboro Parks and Recreation Department) and architect's (GBD Architects) requirements.

The owner, due to cost overruns and a long construction schedule, abandoned a previous design by another team. KPFF, along with the other team members, came up with a design that met both the budget for the project and the design and construction schedule required by the owner. The Hillsboro Parks and Recreation Department received its funding for the stadium from a combination of private and public donations and a recently approved bond measure. When the overall 10-month schedule was broken down into tasks, KPFF was left with 30 days to complete the design and issue bid documents for the stadium, a significant engineering achievement.

KPFF provided structural engineering design and construction services for the Hillsboro Stadium in Hillsboro, OR. The project includes a 4,000-seat bleacher stadium with a 25,000-sq. ft. roof, suspended from four steel towers located along the backside of the stadium. The roof partially covers the bleachers and three enclosed private press boxes that

### Jurors' Comments:

Designed and built in 10 months, this stadium is a perfect blend of simple but elegant design, economy and speed through pre-fabrication. The canopied roof structure stands out like a jewel.

overlook the multipurpose Astroturf field, which supports baseball, football, and soccer. Six additional grass softball and baseball fields surround the stadium.

The seating was constructed using 25' long by 3' 9" wide pre-cast concrete planks supported by structural steel beams and columns. Below the bleachers are restrooms, concession booths, team locker rooms, and ground maintenance and storage facilities. The project was designed and built for the City of Hillsboro Parks and Recreation Department for use by local high schools, youth, and adult sports organizations. Completed in August of 1999, the construction cost for the stadium was \$7,400,000. The stadium included 400 tons of structural steel.

In order to meet the owner's demanding cost and budget constraints, the design team created a simple, structurally sound, and aesthetically pleasing design using prefabricated roof sections that could be installed while the supporting structure was built.

### Concurrent Construction

The key to the project's success was that different sections of the stadium could be designed, built, and installed concurrently. The

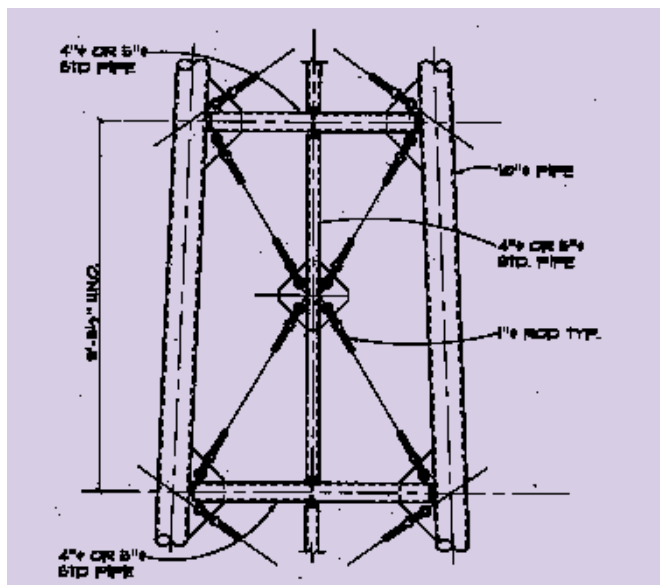
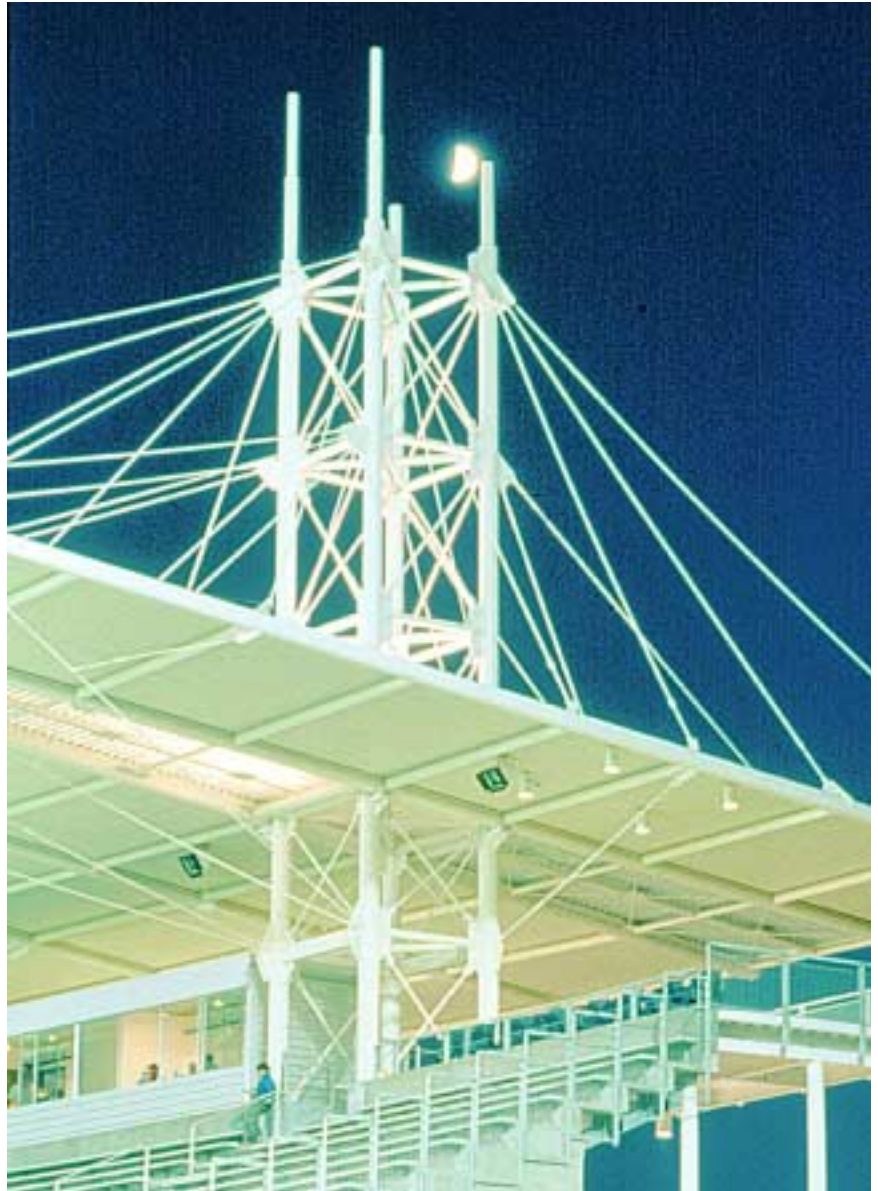



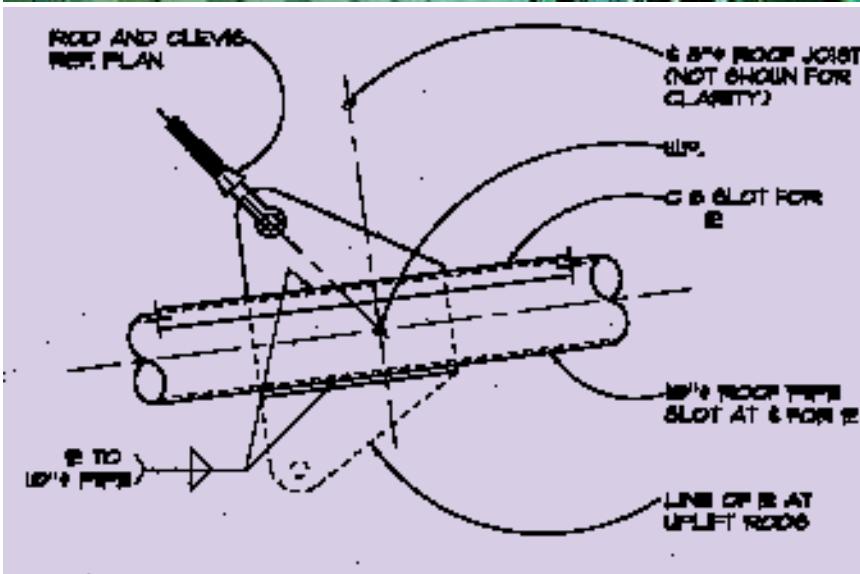

engineers designed a canopied-roof system that was completely independent of the stadium seating section. While the stadium seating area was being constructed, the roof was also being constructed in an adjacent field. Once the seating area was complete, the roof system was lifted into place and attached to 80 suspension rods and 16 uplift rods suspended from four steel towers.

The four steel roof towers were also prefabricated in two sections and lifted into place. The lower sections of the towers were fabricated and placed prior to construction of the seating area.

While the seating area was being installed, the upper roof tower sections were being constructed and were lifted into place prior to completion of the roof panels. The roof panels were constructed in three 53' by 100' sections, which were set between the towers, and two 25' by 100' sections, which were placed at the ends of the roof. Two independent cranes lifted the roof panels. It took approximately eight hours to lift and secure each panel. The framing in the wedge-shaped skylights was installed after the main roof panels were installed.

The suspension rods, which splay out from the top of the towers down to the roof structure, carry all of the gravity load of the roof system. The roof is offset from the roof towers, which creates an inherent eccentricity. The support towers must withstand constant overturning forces caused by the structures' eccentricity, wind, and seismic loads. Additionally, the support towers were designed to accommodate the unbalanced loads that occurred during construction when an adjacent roof panel had not yet been lifted into place. This eliminated the need for shoring and provided the steel erector with a wide range of erection sequences.

The seating raker beams attach to the roof towers, approximately 43' above the field at the press box floor, and provide stability to the roof towers. The steel raker beams act as a compression strut to transfer the loads down to the concourse level, which is 15' above the field level. The concourse level is rigidly anchored to a deep grade beam at the back of the stadium.

The owner was pleased with the aesthetic quality of the system and the design team's ability to create a structural system that could be designed and constructed within the required 10-month period while remaining within the owner's budget. The design team's hard work and innovative use of structural steel made this project a success for everyone involved, including the owner and the members of the community, who will have full use of the facility.



**Hillsboro Stadium,  
Hillsboro, OR**

Owner: The Hillsboro Parks  
and Recreation Department

Architect: GBD Architects,  
Portland, OR

Structural Engineer: KPFF,  
Portland, OR

Fabricator: Fought & Co.,  
Tigard, OR (*AISC member*)

Detailer: Baresel Corp. (*AISC  
& NISD members*)

General Contractor:  
Hoffman Construction Co.,  
Portland