

# Design of Vertical Bracing Connections for High-Seismic Drift

BY WILLIAM A. THORNTON AND LARRY S. MUIR

The effects of frame distortion have been routinely neglected in the design of bracing connections. No longer.

**IT IS COMING TO BE REALIZED** for high-seismic applications where story drifts of 2% to 2½% must be accommodated, that frame distortion cannot be ignored. Such story drifts are on the order of ten times the drifts that are expected for wind and low seismic ( $R \leq 3$ ) design, and they occur in part because the actual maximum considered earthquake (MCE) forces are reduced to about ½ of the forces such an event could produce. This is done by first using ⅓ of the MCE forces and then dividing them by an “R” factor on the order of 6, so the MCE load reduction factor is  $6 \times \frac{1}{2} = 9$ .

The rationale for this reduction factor is twofold: 1) The forces are of short duration and are reversing, so the response to them does not necessarily achieve the maximum values; and 2) It allows economical designs to be achieved. The price paid for this MCE force reduction is the high drift and the requirement for ductile response that allows large distortions without fracture and resulting building collapse. If one used an  $R$  of 1, or even ⅓, the drift under even the MCE forces would be no greater (and probably less because of the duration factor) than traditional wind design. Some designers of hospitals and nuclear power plants do just this. However, the current AISC *Seismic Provisions* (2005) have no requirement to consider frame distortions and the resulting distortional forces.

## Distortional Forces

These forces exist because a braced frame, although considered a pinned structure, is in reality a braced rigid frame. They would be reduced to essentially zero by the use of an actual pin, as shown in Figure 1, or they can be controlled by the use of a designed hinge in the beam, as shown in Figure 2 (both on next page). If no pin or hinge is used, the maximum distortional forces can be derived from the maximum distortional moment,  $M_D = \min\{2M_{P_{column}}, M_{P_{beam}}\}$

In this formula, the column is considered continuous above and below the location being considered. Figure 3 shows a statically admissible distortional forces distribution. These forces are to be added algebraically to those resulting from the Uniform Force Method (AISC 2005) of bracing connection analysis.

Note that when the brace force is tension, the distortional forces  $F_D$  are compression. These forces tend to “pinch” the gusset

and can cause it to buckle even when the brace is in tension. This gusset pinching has been observed in physical tests.

## For Example...

Figure 4 shows a connection designed to satisfy the current *Seismic Provisions*. This design, which does not consider distortional forces, is given in the AISC *Design Guide for Vertical Bracing Connections* (2009). The statically admissible interface forces for the connection of Figure 4 are given in Figure 5. These forces would be correct if a beam hinge, such as shown in Figures 1 or 2, were used. However, with no hinge, as shown in Figure 4, the maximum possible (demand) distortional moment is

$$\begin{aligned} M_D &= \min\{R_y M_{P_{beam}}, 2R_y M_{P_{column}}\} \\ &= \min\{1.1(826), 2(1.1)2260\} \\ &= 909 \text{kip-ft} \end{aligned}$$

From the geometry of Figures 3 and 4,

$$F_D = \frac{M_D}{\beta + e_b} \left( \frac{\beta}{\bar{\alpha}} \right)^2 = \frac{909}{14.5 + 8.5} \left( \frac{14.5}{18} \right)^2 = 609 \text{kips}$$

where  $e_b$  is the half depth of the beam.

The horizontal component of  $F_D$  is

$$H_D = \frac{\bar{\alpha}}{\sqrt{\bar{\alpha}^2 + \beta^2}} \times 609 = 474 \text{kips}$$



William A. Thornton is with Cives Engineering Corporation, Roswell, Ga., and Larry S. Muir is a steel consultant based in Atlanta.

This article has been excerpted from a paper to be presented at The Steel Conference, April 1-4 in Phoenix, Ariz. Learn more about The Steel Conference at [www.aisc.org/nascc](http://www.aisc.org/nascc). The complete paper will be available with the archived version of this article at [www.modernsteel.com/backissues](http://www.modernsteel.com/backissues).

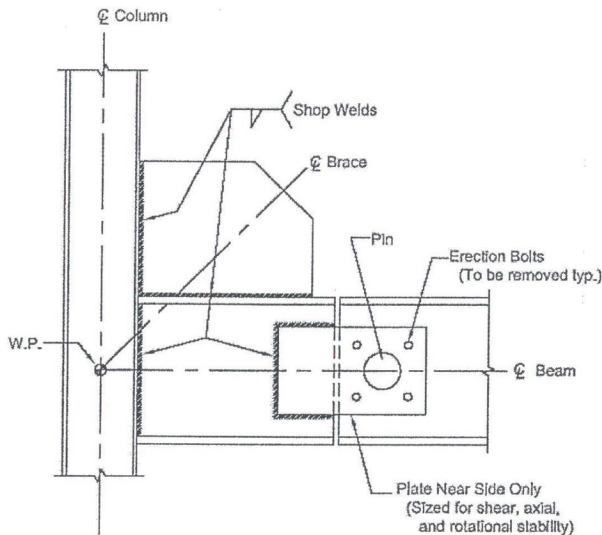

Figure 1. Connection to Minimize Distortional Forces

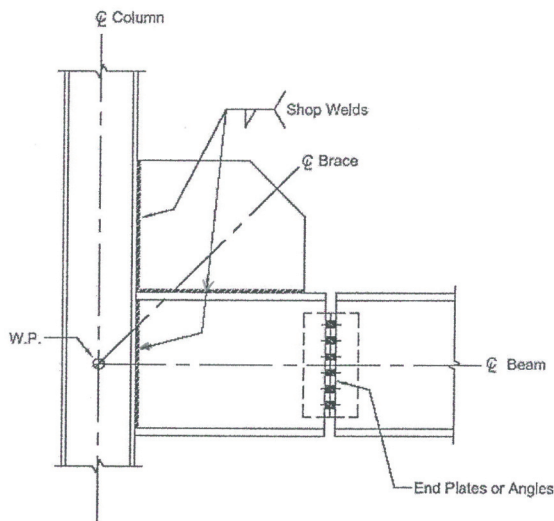

Figure 2. Shear Splice to Control Distortional Forces

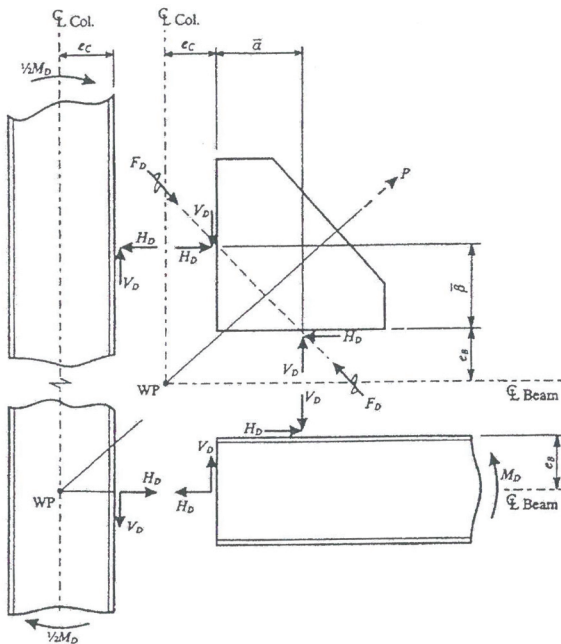

Figure 3. Admissible Distribution of Distortional Forces

This value, which is compression when the brace force is tension, can be compared to the 176-kip horizontal force of Figure 5 between the gusset and the column, which is tension when the brace force is tension. It can be seen that it is not reasonable to neglect the distortional forces.

Note that the large distortional forces may not be able to be achieved because of column and beam web yielding and crippling and gusset pinching (buckling when the brace is in tension). The AISC *Design Guide* proposes using the plate buckling theory given in the AISC *Manual* on pages 9-8 and 9-9 (2005) to control gusset pinching. The *Manual* formulation can be written as

$$F_{cr} = QF_y$$

$$Q = 1.0 \text{ for } \lambda \leq 0.7 \text{ (yielding)}$$

$$Q = 1.34 - 0.486\lambda \text{ for } 0.7 < \lambda \leq 1.41 \text{ (inelastic buckling)}$$

$$Q = \frac{1.30}{\lambda^2} \text{ for } \lambda > 1.41 \text{ (elastic buckling)}$$

$$\lambda = \frac{\left(\frac{b}{t}\right)\sqrt{F_y}}{5\sqrt{475 + \frac{1120}{\left(\frac{a}{b}\right)^2}}}$$

where

$a$  = length of “free” edge – distance between points A and B of Figure 4.

$b$  = the perpendicular distance from the “free” edge to the gusset junction point at the beam and column, point C of Figure 4. The parameters  $b/t$  (slenderness ratio) and  $a/b$  (aspect ratio) are the basic geometry parameters for plate buckling.

From the geometry of Figure 4,

$$a = 44.3 \text{ in. } b = 21.2 \text{ in.}, t = \frac{3}{4} \text{ in.}$$

$$\frac{a}{b} = 2.09, \frac{b}{t} = 28.3$$

$$\lambda = \frac{28.3\sqrt{50}}{5\sqrt{475 + \frac{1120}{2.09^2}}} = 1.48$$

$$Q = \frac{1.30}{1.48^2} = 0.594$$

$$\phi F_{cr} = 0.9 \times 0.594 \times 50 = 26.7 \text{ ksi}$$

The actual stress is

$$f_a = \frac{609}{0.75 \times 21.2} = 38.3 \text{ ksi}$$

Since  $38.3 \text{ ksi} > 26.5 \text{ ksi}$ , the gusset will buckle in the pinching mode when the brace is in tension. This buckling will prevent the distortional moment  $M_b = 909 \text{ k-ft}$  from being achieved, but this out-of-plane buckling is undesirable because it could cause low cycle fatigue cracks to form in the gusset and its connections.

### Beam Hinges

The idea is shown in Figures 1 and 2 and has been tested in the context of buckling restrained braced frames. A completely designed example with a beam hinge is shown in Figure 6. The

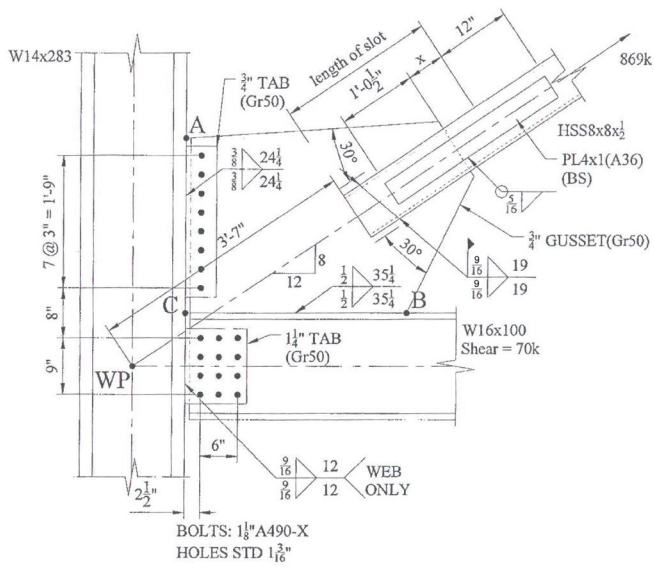

Figure 4. SCBF Connection

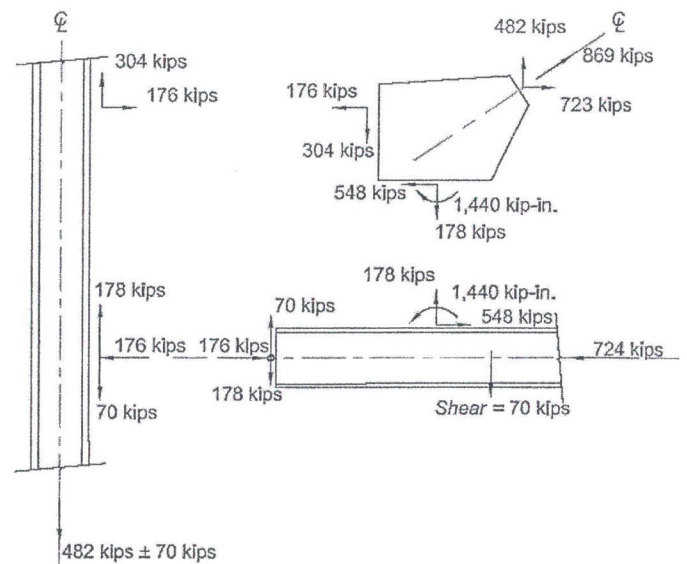

Figure 5. Admissible Force Field for Connection of Figure 4

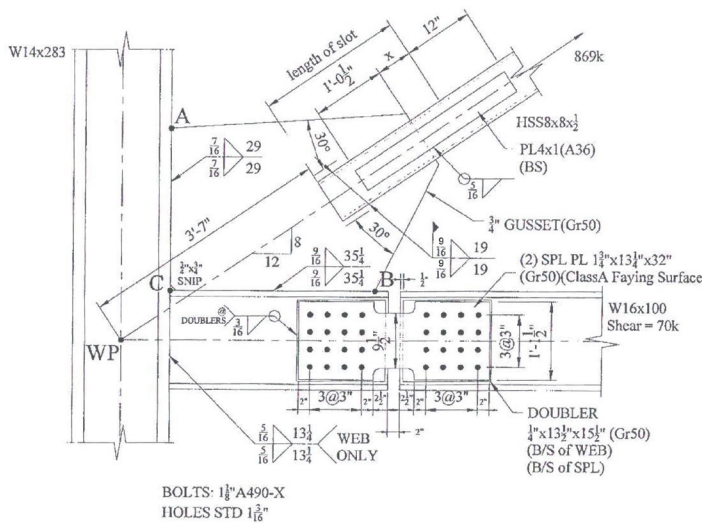

Figure 6. High-Seismic Design Including Distortional Forces

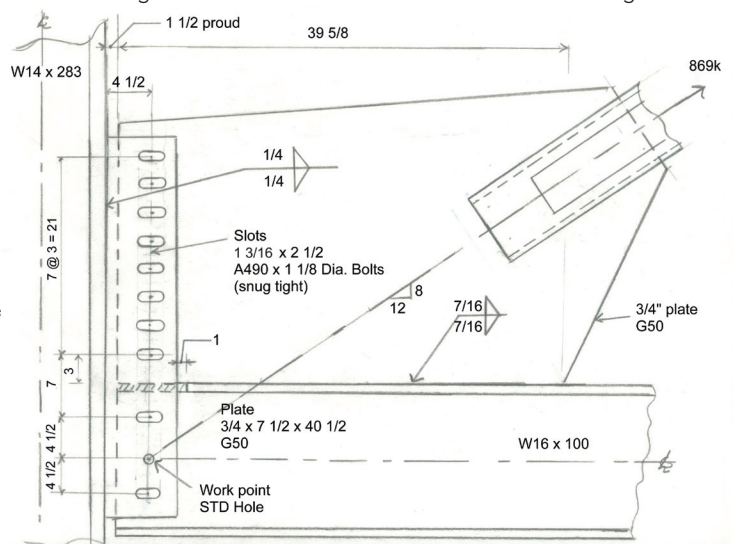

Figure 7. Arrangement to Eliminate Distortional Forces

loads and geometry are the same as the example of Figure 4. The *Design Guide* gives complete calculations for this example. Because of the beam hinge, the distortional force  $F_D$  is reduced to 204 kips. The design shown in Figure 6 satisfies all the usual limit states, plus gusset pinching, with the original 3/4-in. gusset plate.

### Work Point Location and Avoiding Binding

The usual work point location is at the intersection of the member gravity axes. This is done to adhere to the usual design assumption of pin-ended members in braced frames. A paper by both authors of this article suggests that the work point may be moved to a point that allows the pin-ended assumption to be achieved. Figure 7 shows the concept. The work point is moved to the centroid of the beam to column connection. At or near the work point, a standard hole in both the shear plate and the beam web is used to control the geometry of the structure. All of the other holes in the shear plate are special slots of a length to prevent the bolt from contacting the end of the slot during the specified required story drift. Standard holes are used for all holes in the beam web and the gusset. The setback (or proud) dimension between the gusset and

beam and the face of the column flanges is taken large enough to prevent binding as well.

The design shown in Figure 7 is for a 2 1/2% drift. The 1/2-in. setback and the 1/16-in. by 2 1/2-in. slots will accommodate this drift without binding. The admissible force field for the design of Figure 7 is given in Figure 8. Note that the work point location of Figure 7 results in a column moment of 482 (8.375 + 4.5) + 70 × 4.5 = 6520 K-in. If the column is continuous, this can be split into moments of 3,260 K-in. above and below the connection. The column must be designed for these moments in addition to the axial force it must carry.

Note also that within this model, gusset pinching is not a limit state and that the concrete floor slab must be held back from the column with a soft spacer, such as Styrofoam, for a distance similar to the setback dimension to prevent binding and spalling of the concrete and the inducement of unexpected loads in the steel.

### Fillet vs. CJP

The welds of the gusset to the beam and column shown in Figures 1 and 2 are fillet welds. The welds of the gusset or shear plates



to the beam and column, in the actual examples for Figures 4, 6, and 7, are shown as fillet welds. The reason for this is twofold: First, fillets are generally less expensive than CJP welds and second, fillets are stronger than CJP welds in resisting gusset out-of-plane bending.

Out-of-plane gusset bending is an issue when low-cycle high-stress (strain) fatigue occurs due to gusset buckling out-of-plane. This is thought to have caused fracture in the tests of Lopez at el (2004). Consider Figure 9, which shows a cross section of the gusset or shear plate and the beam or column flange and web. When a moment  $M$  is induced in the gusset due to buckling, the fillet welds resist with the forces  $F$  spaced at the distance  $e = t_g + 2/3w$  shown. With E70 electrodes and LRFD format,

$$F = (0.75)(0.6)(70)(1.5) \frac{w}{\sqrt{2}} = 33.4w$$

For the fillets to be stronger than the expected strength of the plate,

$$Fe \geq \frac{1}{4} t_g^2 R_y F_y$$

and

$$33.4w(t_g + \frac{2}{3}w) \geq \frac{1}{4} t_g^2 R_y F_y$$

Solving for the weld size  $w$

$$w \geq t_g \left( \frac{1}{2} \sqrt{2.25 + 0.045 R_y F_y} - 0.75 \right)$$

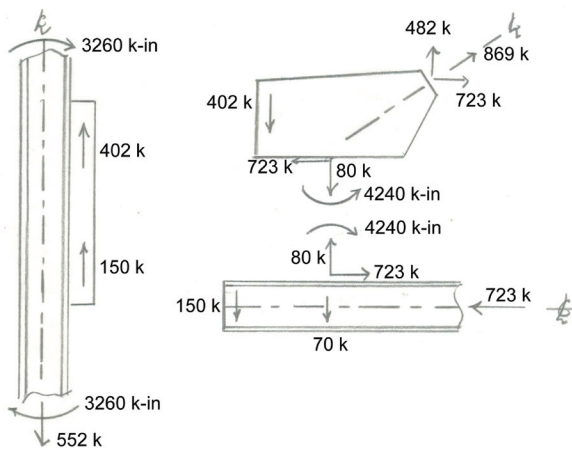

Figure 8. Admissible Force Field for the Connections of Figure 7

A weld size  $w$  that satisfies the above inequality will be stronger than the gusset in flexure.

For

$$t_g = 0.75 \text{ in. } R_y = 1.1, F_y = 50 \text{ ksi.}$$

$$w \geq 0.252 \text{ in.}$$

From Figure 7 the required gusset to beam weld of  $7/16$  in.  $>$  0.252 in., so the gusset (or the beam web at the  $k$  distance) will yield before the weld fractures. Also from Figure 7, the required shear plate to column weld is  $1/4$  in., which is within 0.8% of the flexural strength minimum of 0.252 in.

### New Guide Coming

A forthcoming AISC *Design Guide for Vertical Bracing Connections* (2009) treats many types of bracing connections and loadings. This paper, part of which is abstracted from the original *Design Guide*, presents two rational state-of-the-art treatments of the potential distortional forces induced by large seismic drifts.

In the first, the distortional forces are controlled by a beam hinge and in the second, they are controlled by work point location and detailing to prevent binding.

MSC

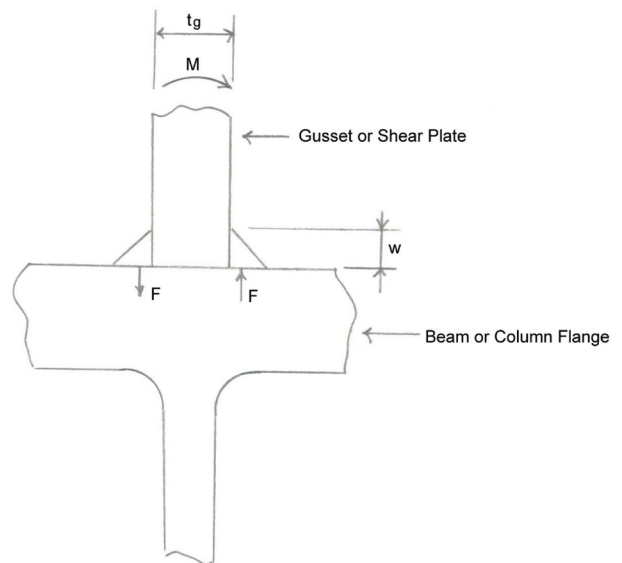

Figure 9. Section of Gusset or Shear Plate and Beam or Column

### References

AISC (2008), *Design Guide for Vertical Bracing Connections*, W.A. Thornton and L.S. Muir (to appear).  
 AISC (2005), *Manual of Steel Construction*, 13th Edition, AISC, Chicago.  
 AISC (2005), *Seismic Provisions for Structural Steel Buildings*, AISC, Chicago.  
 Fahnestock, Larry A., Ricles, James M., and Sause, Richard, (2006) "Design, Analysis, and Testing of an Earthquake-Resistance Buckling-Restrained Braced Frame," *SEAOC 75th Annual Proceedings*.

Lopez, Walterio A., Gwie, David S., Lauck, Thomas W., and Saunders, Mark (2004), "Structural Design and Experimental Verification of a Buckling-Restrained Braced Frame System," *AISC Engineering Journal*, Fourth Quarter, p. 177-186.  
 Walters, Mason T., Maxwell, Benjamin H., and Berkowitz, Russell H. (2004), "Design for Improved Performance of Buckling-Restrained Braced Frames," *SEAOC Annual Convention Proceedings*.  
 Muir, Larry S. and Thornton, William A., (2009), *Vertical Bracing Connections for Moderate Seismic Demand*, ASCE Structures Congress, Austin, Texas (to appear).