



# Science on Display

BY MARK KANONIK, P.E., LEED AP, AND ELIZABETH CHRESTLER

Steel framing facilitates combining historical style with contemporary functionality in Union College's new Peter Irving Wold Science and Engineering Center.

**FOUNDED IN 1795** and located in Schenectady, N.Y., Union College was the first college chartered by the Board of Regents of the State of New York. A small, independent liberal arts institution, it is committed to integrating the humanities and social sciences with science and engineering in new and exciting ways. Union College is also the first master-planned college campus in the United States, serving as a model for the planners of the University of Virginia, among others. As the college grew, its connection with the original 1812 master plan waned. However, the recently dedicated Peter Irving Wold Science and Engineering Center recaptures the campus identity through adaption of original architectural vocabulary, while creating a “face” for the science and engineering departments.

The 35,000-sq.-ft facility consists of a ground floor, two elevated floors, and a mechanical penthouse. The overall construction budget was approximately \$16 million, including \$2 million for utility

relocation and site preparation. Early on in the project, two framing systems were evaluated: a flat plate concrete structure and a traditional steel structure. Initial cost estimates concluded that a concrete structure would cost about \$250,000 more than a steel structure.

Erection of the steel superstructure took just a couple of weeks in late fall and early winter without the concerns of cold-weather construction that concrete has, further reinforcing the benefits of steel construction beyond that of a lower first cost. Approximately 241 tons of structural steel went into the project. The building framing was analyzed and designed using the program ETABS.

A key performance criterion for any science building is controlling structure vibrations, and the Wold Center is no exception. Much of the science and engineering departments is located within the Olin Building, which opened in 1998, and the Science and Engineering Building, which opened in 1968, both of which



Aerial Dimensions

- ▲ The main entrance complements a curved colonnade that was part of the original 1812 master plan.
- ▼ All engineering disciplines except for plumbing were completed by using the building information modeling (BIM) software Revit, supporting the ongoing coordination among disciplines.



A.J. Martin

- ▲ The atrium framing includes horizontal bracing in the roof plane.

were designed and constructed to different vibrational criteria than what is required for today's sophisticated laboratory equipment. Consequently, some highly sensitive equipment could only be used with advanced planning, an issue that the college wanted to address. The steel superstructure of the Wold Center was designed in accordance with criteria in AISC's *Steel Design Guide No. 11, Floor Vibrations Due to Human Activity*, with critical structural accelerations in the laboratories set at 2900 micro-in. per

*Mark C. Kanonik, P.E., LEED AP, is a senior structural engineer in the Albany, N.Y., office of EYP Architecture & Engineering. He has 22 years of experience. Elizabeth J. Chrestler, LEED AP, has seven years experience and is a structural engineering designer with the same firm in its Washington D.C. office. Both are AISC Professional Members.*



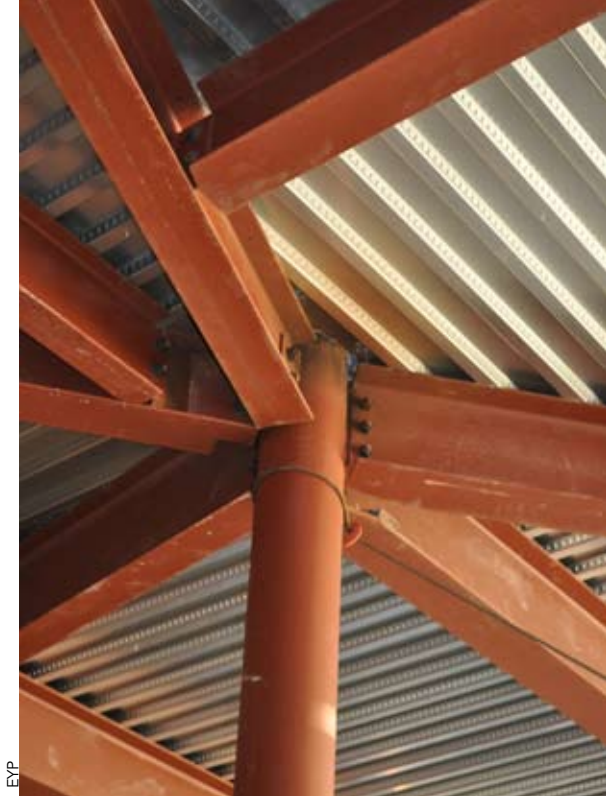

EYP

▲ Fig. 1: Pipe columns permit the use of standard connections when beams are skewed to the columns.

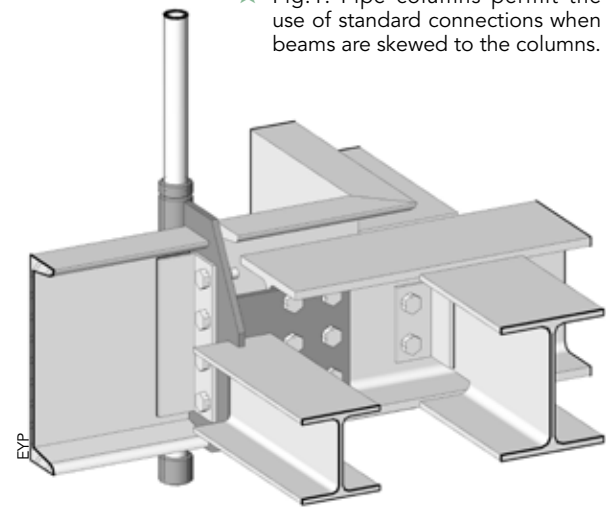

EYP

▲ Fig. 2: Three-dimensional detailing of the hanger connection simplified design, fabrication and construction.

▼ Fig. 3: A multitude of utilities within the footprint of the building created challenges but resulted in a pleasant surprise.



EYP

second based on a “moderate walking speed” and 900 micro-in. per second based on a “slow walking speed.”

Because the Wold Center connects two adjacent buildings, the floor-to-floor height within the Center had to match the adjacent buildings, resulting in floor-to-floor heights as low as 12 ft at the ground floor. Steel floor framing was initially limited to W14s to provide as much room as possible for the utilities, but shallow framing tends to worsen, not improve, vibrational characteristics. Column spacing was arranged around a 10 ft, 3 in. by 25 ft laboratory module, resulting in column bays of 21 ft by 25 ft in the laboratories—a relatively “tight” column spacing but necessary to achieve the desired vibrational characteristics. Laboratory spaces are located along exterior walls and separated from corridors and public spaces by classrooms and support spaces to further isolate them from the effects of people walking nearby. Filler beams are also spaced at a relatively close spacing of 6 ft, 8 in. on center to meet the desired vibrational characteristics of the floor system. Column bay sizes were increased in the classrooms and offices where vibration criteria was relaxed somewhat.

The Wold Center’s office wing is nearly one-quarter of a circle in plan, with an outer radius of approximately 90 ft and an inner radius of 60 ft, complimenting a curved colonnade in front of the building that was part of the original 1812 master plan. Only a few edge beams were horizontally curved, but connecting the rectangular laboratory wing with the curved office wing created some framing challenges, most notably five beams framing into a single column (see Figure 1). Pipe columns in lieu of traditional wide-flange shapes greatly simplified the connections, allowing the use of standard single-plate shear tab connections.

As the HVAC design progressed, a limited number of beams were increased to W16s, where the ductwork sizes and ceiling clearances permitted, to reduce dead-load deflections, to improve vibrational performance, or where a non-standard connection of the beam to a pipe column would have been required to carry gravity loads. All engineering disciplines except for plumbing were completed by using the building information modeling (BIM) software Revit. Given the shallow floor-to-floor heights and large quantity of utilities above each ceiling, weekly (and sometimes even daily) coordination between all disciplines was implemented to ensure that everything fit within its place.

Within the atrium, the second floor overlooking the atrium is hung from the low roof with rods and is connected to both the third floor entrance and the atrium floor via open stairs. The hanger connection presented a formidable engineering challenge, as the client wanted to make the connection as “clean” as possible without turnbuckles, clevises, and the like. The hanger itself takes its form from that of a cable-stayed bridge, and a 3D representation of the hanger was included in the contract documents when it became clear that traditional 2D detailing would be insufficient to fully explain the complicated construction of the hanger (see Figure 2). The hanger cable is a solid rod with threaded ends, but the threads are hidden within the beam-to-rod connection. A solid 1¾-in.-thick plate 2⅜ in. in diameter was tapped to create an oversized “nut” on which the beam-to-rod connection rested; this greatly simplified construction while allowing for adjustability of the connection.

Even though the new Wold Center connects two existing buildings, the site presented significant design and construction challenges. For instance, the grade within the Center’s footprint varies by 15 ft, and new foundations could not be placed close to the Olin Building without overstressing its basement walls. Furthermore, every major campus utility, including steam, electric, chilled water, telephone, and fiber optic communications, ran through the site (see Figure 3). Early in the project’s schematic design phase, the design team discussed several options for dealing with the utilities, including leaving them in place with a new foundation system spanning over the utilities as well as routing the utilities off-site and around the Olin Building. While every option was disruptive and time-consuming, it was ultimately

decided to route the utilities directly under the Wold Center, placing them all within a precast concrete box culvert with a trunk running adjacent to the Olin Building.

Preliminary design concepts called for the first floor atrium slab to be on-ground, meaning that the grade adjacent to the Olin Building would be raised, but this would have overstressed the basement walls. The soils had to be removed to install the utility tunnel, but it made no sense to then backfill the same soils that were just excavated. Though the cost to install the utility tunnel and to construct an elevated atrium floor was slightly higher than routing the utilities off-site, this decision had the unintended benefit of adding nearly 3,000 sq. ft of shell space to the ground floor with a minimal increase in the project's overall cost.

The Wold Center was designed to achieve LEED Gold status from the U.S. Green Building Council through the incorporation of many sustainable features; the use of structural steel, one of the most recycled building materials commonly available, was critical to this aspect of the project, and formal certification is expected soon.

Union faculty and students are engaged in cutting-edge research in renewable energy sources and energy-saving materials, and the Center is designed to be a "living laboratory" for sustainable practices. The roof of the atrium is home to the Roof-Top Energy Lab, where student-designed experiments can be set up, fully instrumented, and monitored continuously to evaluate their performance under actual outdoor conditions. Stainless steel tie-down plates are incorporated into the rooftop pavers to anchor equipment and experiments. Also, several panes of glass in the atrium clerestory are coated with different energy-saving coatings and are instrumented to provide real-time data to a kiosk in the atrium.

When Union College President Stephen Ainley selected the design team, he presented many challenges, including difficult site constraints and connecting two architecturally different buildings while respecting a historic, 200-year-old master plan, all within a modest budget. The Peter Irving Wold Science and Engineering Center at Union College successfully met these challenges through careful and deliberate inclusion of the Center's end-users, thoughtful architectural detailing that is respectful of the original master plan, and expertise-driven design in all disciplines. With its emphasis on interdisciplinary study and on the intersection between engineering and the traditional liberal arts and sciences, the Center further solidifies the college's excellence in educating undergraduates broadly and deeply, equipping them to make important contributions in the 21st century. MSC

#### Owner

Union College, Schenectady, N.Y.

#### Architect and Structural Engineer

EYP Architecture & Engineering, Albany, N.Y.

#### Construction Manager

A.J. Martini, Inc., Boston

#### Steel Fabricator

Bennington Iron Works, Bennington, Vt.  
(AISC Member)

#### Steel Erector

Green Mountain Steel Erectors, Inc., Bennington, Vt.  
(SEAA Member)



▲ Careful planning reduced the number of horizontally curved beams in the office wing to a minimum.



#### An Academic Town Square

Within hours after opening its doors to students and faculty, the Wold Center became the heart of campus. Its public spaces draw Union's liberal arts tradition into closer collaboration with science and engineering, breaking down the distinctions between teaching and research. Further, the central glass-walled atrium creates an academic town square where informal student and faculty collaborations take place and where members of the campus and surrounding communities come together for academic, social, and artistic programs.

Visitors to the atrium immediately notice a colorful set of lines integrated into the second-floor railing. The lines represent the light pattern emitted by the chemical oxygen when its atoms release photons as they fall into lower energy levels. Not only is oxygen an essential element for human life, it is closely tied to the core activities in the Wold Center. The oxygen spectrum symbolizes that there are fundamental elements in life, just as there are common aspects of teaching and research that take place in disparate disciplines.