

# steel quiz

The answers to this month's Steel Quiz can be found in AISC Design Guide 13 *Wide-Flange Column Stiffening at Moment Connections* as well as on the AISC and *Modern Steel Construction* websites ([www.aisc.org](http://www.aisc.org) and [www.modernsteel.com](http://www.modernsteel.com)).

1 For the following questions, assume that the inflection point is at the midpoint of each story and that the story heights are equal to 12 ft. Also assume that the beam axial load is transferred through the beam flange only and that the effect of panel-zone deformation on frame stability is not considered in the analysis.

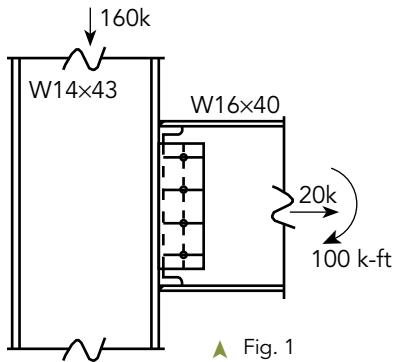

Use the loads shown in Figure 1 for ASD for design, or 1.5 times the loads shown for LRFD.

- What is the story shear,  $V_c$ ?
- How does the axial load affect the web panel zone shear check?
- What is the required web panel zone shear strength,  $V_p$ ?

2 Determine the maximum panel zone shear,  $V_p$ , for the interior column shown in Figure 2. Assume an inflection point at mid height of each story, and that the W21x50 is CJP groove welded to the W14 column flange. Use the following moments for ASD, or 1.5 times these moments for LRFD.

- ▶ Dead load moment from each beam,  $M_{DL} = 30.0$  kip-ft
- ▶ Live load moment from each beam,  $M_{LL} = 37.5$  kip-ft
- ▶ Moment due to wind load,  $M_{W-1} = M_{W-2} = 40.0$  kip-ft

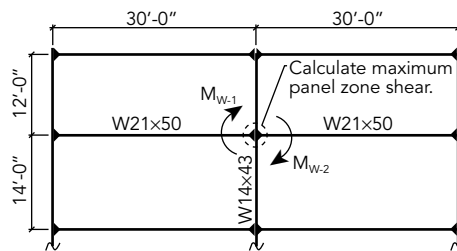

▲ Fig. 2

3 If you are checking panel zone shear for an OMF, IMF or SMF connection, can equations J10-11 and J10-12 in the 2010 AISC Specification be used?

4 Size the doubler plate thickness required along with the required weld sizes for Weld A and Weld B shown in Figure 3. The required shear strength of the doubler plate,  $V_{DP}$ , is equal to 30 kips for ASD and 45 kips for LRFD. Use ASTM A36 plate material.

- Adding a column web doubler
- Adding a full depth stiffener
- Upsizing a column to avoid the use of a stiffener and/or doubler
- Adding a partial stiffener

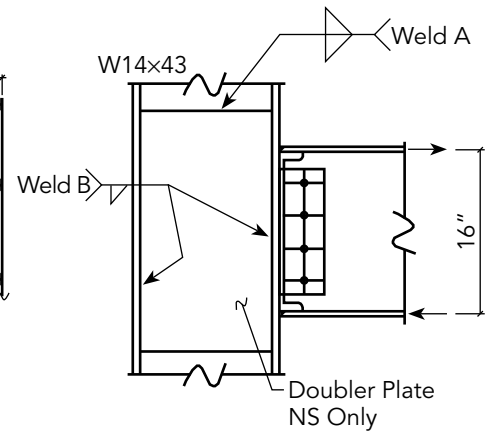

▲ Fig. 3

TURN TO PAGE 14 FOR ANSWERS

1 a) The story shear,  $V_c$ , is determined by dividing the sum of the moments transferred to the column by the distance between the inflection points,  $h$ . The total moment transferred to the column is equal to 100 ft-k and the distance between the panel points is equal to 12 ft. Therefore,  $V_c = 100 \text{ kip-ft}/12 \text{ ft} = 8.33 \text{ kips}$  for ASD; 12.5 kips for LRFD by similar process (see Figure 4, below).

b) The axial load transferred to the column does not affect the shear in the panel zone, just the shear in the column below the panel zone. Note that Section J10.6 states, "This section applies to double-concentrated forces applied to one or both flanges of a member at the same location." Double-concentrated force is defined in the AISC *Specification* as "two equal and opposite forces applied normal to the same flange, forming a couple."

c) The required web panel zone shear strength,  $V_{p1}$ , is equal to the beam flange force due to the moment (the axial force is ignored in this calculation), minus the story shear (see Figure 4). The flange force,  $P_f$ , is equal to the moment divided by the moment arm, which is equal to the depth of the beam minus the thickness of the beam flange. For ASD,  $P_f = 100 \text{ kip-ft} \times 12 \text{ in./ft}/(16 \text{ in.} - 0.505 \text{ in.}) = 77.4 \text{ kips}$ , and  $V_p = 77.4 \text{ kips} - 8.33 \text{ kips} = 69.1 \text{ kips}$ . For LRFD, by similar process,  $P_f = 116 \text{ kips}$  and  $V_p = 104 \text{ kips}$ .

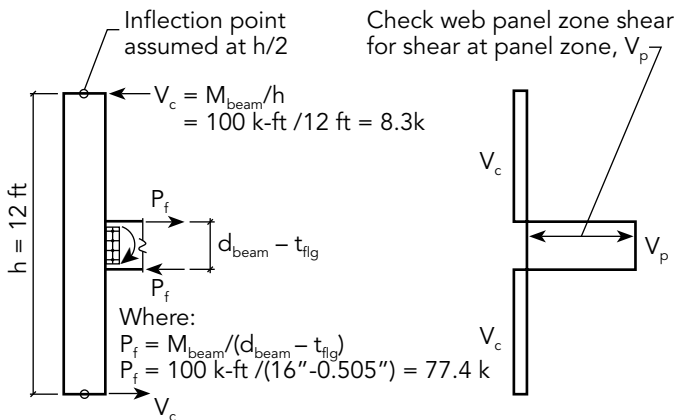

▲ Fig. 4

2 For the ASD solution, the required shear strength for the panel zone is 33.0 kips. The moment due to dead load is equal and opposite on both sides of the column and cancels out. To maximize the panel zone shear, live load is considered on one side only, and the controlling load combination is  $0.75L + 0.75(0.6W)$ . The sum of the moments at this location is equal to  $0.75M_{LL} + 0.75 \times 0.6 (M_{W1} + M_{W2}) = 0.75 \times 37.5 \text{ kip-ft} + 0.75 \times 0.6 \times (40.0 \text{ kip-ft} + 40.0 \text{ kip-ft}) = 64.1 \text{ kip-ft}$ . The distance between the inflection points is equal to  $(12 \text{ ft}/2) + (14 \text{ ft}/2) = 13 \text{ ft}$ .

The story shear is  $V_c = 64.1 \text{ kip-ft}/13 \text{ ft} = 4.93 \text{ kips}$ . The required strength for the web panel zone shear is equal to the total flange force (sum of moments divided by the moment arm) minus the story shear. This equals  $V_p = [64.1 \text{ kip-ft} \times 12 \text{ in./ft}/(20.8 \text{ in.} - 0.535 \text{ in.})] - 4.93 \text{ kips} = 33.0 \text{ kips}$ . For LRFD, the corresponding answer by similar process is 49.5 kips.

3 Yes. Commentary Section E1.6b in the AISC *Seismic Provisions* states: "The required shear strength of the panel zone may be computed from the basic code prescribed loads, with the available shear strength computed using Equations J10-11 and J10-12 of the *Specification*. This may result in a design where initial yielding of the frame occurs in the panel zones. This is acceptable behavior due to the high ductility exhibited by panel zones."

4 For LRFD, the required web doubler plate thickness is equal to  $t_{DP} = V_{DP}/(\phi \times 0.6 \times F_y \times d_{col}) = 45 \text{ kips}/(0.9 \times 0.6 \times 36 \text{ ksi} \times 13.7 \text{ in.}) = 0.168 \text{ in.}$  The ASD solution results in the same thickness by similar calculation. Use a  $1/4$ -in. plate.

For Welds A the flange force is delivered directly to the doubler, and these can be minimum-size fillet welds. For Welds B, the shear load that is transferred is equal to  $45 \text{ kips} \times 16 \text{ in.}/(13.7 \text{ in.} - (2 \times 0.53 \text{ in.})) = 57.0 \text{ kips}$ . The weld length is equal to 16 in. Therefore the required fillet weld leg size =  $57.0 \text{ kips} / 1.392 \text{ kips/in.}/\text{sixteenth} \times 16 \text{ in.} = 2.6 \text{ sixteenths}$ . The ASD solution results in the same requirement by similar calculation.

Can we use a  $3/16$ -in. fillet weld? Probably not, because a fillet weld detail must account for the plate bevel and its effect on the doubler capacity; the bevel changes the effective throat in most cases (this is illustrated in AISC Design Guide 13). This can be accounted for by making the plate thicker or the fillet weld larger or both. Depending on the preference of the fabricator, it may be more economical to prepare the doubler plate and use a groove weld. Refer to Figure 4-13 in AISC Design Guide 13 for more information.

5 c) Almost always. When it comes to designing column doublers and/or column stiffeners, it is nearly always more economical to size a column to avoid adding these types of reinforcement because shop labor is far more expensive than material cost. Sometimes, stiffening can't be avoided—but when it can it should be.



Anyone is welcome to submit questions and answers for Steel Quiz. If you are interested in submitting one question or an entire quiz, contact AISC's Steel Solutions Center at 866.ASK.AISC or at [solutions@aisc.org](mailto:solutions@aisc.org).