



# Well READ

BY DEAN HUTCHISON

One of D.C.'s oldest public libraries gets a makeover that bridges its early 20th century aesthetic with early 21st century practicality.

Maxwell Markenzie



**Dean Hutchison** ([cdh@coredc.com](mailto:cdh@coredc.com)) is a job captain with CORE.

**DESPITE THE RISE** in reading books on electronic devices, libraries are still important anchors in their communities (and many even allow card-carrying members to check out books for use on their devices).

The Mount Pleasant Neighborhood Library, located in the diverse Mount Pleasant neighborhood of Washington, D.C., is a beloved branch, known for its Spanish language collection and widely attended children's story time.

Dedicated in 1925, the Library was the third and final D.C. Public Library (DCPL) building constructed with funding from Andrew Carnegie. As part of the Mt. Pleasant National Register

Historic District, the library was designated historic in 1987 and is the third-oldest public library still in use in Washington.

Although beloved, the library had fallen into disrepair, and renovations over the years had altered the intended flow and design integrity of the original building. In addition, DCPL's Branch Library Program required that the library be expanded to keep up with the modern needs of a public library and come into compliance with modern codes. Architects CORE and HMA2 were selected to lead a team through a major renovation, restoration and expansion of the library in an effort to preserve the building's heritage and meet the changing needs of the neighborhood.

### Opening Closed Spaces

The main goal of the project was to increase the amount of usable space within the historic library and open up spaces that had become inaccessible due to previous renovations, utility functions and space limitations. An addition would be primarily used to house staff space, mechanical equipment and a replacement for the existing basement meeting room.

Tucked into a five-sided site in a residential neighborhood, the question of where to put the addition and how to attach it to the historic structure became crucial to the success of the project. In response, CORE contracted with ReStl Designers, Inc., as the structural engineers. ReStl provided invaluable input into designing a structure that not only had to be compatible with the existing building, but also had to squeeze into the limited amount of available property behind the existing structure. As a result, CORE designed a three-story addition with a concrete foundation and wide-flange structural framing from the first floor up.

Structural steel proved to be a prudent choice to allow the design to work within the complex geometries of the site and existing building. The addition is a wedge shaped "prow" that peaks out along the side of the existing building. The new structure frames an accessible entry and tranquil garden path to ul-

timately bring visitors into the main library under a metal-clad canopy. The canopy, framed by wide-flange members, is hung off the main structure by a HSS20x12x½ beam and provides a moment of tension before the openness of the interior architecture.

Structural analysis indicated that the masonry walls of the existing building could take a small amount of additional gravity load, but the addition needed to remain laterally independent. This resulted in a partial expansion joint between the two buildings. The composite framed slab at the first floor of the addition is totally separated from the existing building, bearing on new 5-in.-diameter HSS columns dropped adjacent to the existing perimeter. Above this level is a two-story open glass atrium serving to tie the existing building to the new addition. Both the second-story pedestrian bridge and the skylight framing at the roof are connected to the existing bearing wall with parallel long-slotted connections to transfer gravity load but not lateral load. Innovative flexible flashing details have been designed to accommodate these movements while precluding leaks and uncontrolled infiltration.

### Old Meets New

When entering the atrium, one simultaneously experiences the limestone exterior of the existing building and the terra-cotta exterior of the new building. Inserted into the atrium is a steel-framed monumental stair that rests on minimal HSS6x3 structural steel sections tied back to the addition framing. The steel-framed bridge at the second floor delicately brings the two structures together. In order to achieve the connection as minimally as possible, the bridge stringers are slotted into a bent steel plate welded to a face plate embedded into the existing structure.

The new building is skinned with terra-cotta, a modern use of a traditional material, realized as panels to form a rain screen wall with terra-cotta rods at the windows to provide shade to the interiors. The material was chosen as a reminder of the terra-cotta roof on the existing building, and the pattern of the panels reflects

- ◀ The atrium is slotted between the new and existing buildings. This part of the existing building's face was previously exposed to the outdoors and only visible from an inaccessible rear yard. The newly restored exterior now takes center stage as visitors enter the library. A steel-framed bridge connects the second floor of the addition through an expanded opening that was once a window to the exterior.
- ▼ The pedestrian bridge, prior to cladding.
- ▼ The prow at the new entry. The canopy support beam can be seen below the second-floor framing member.
- ▼ Supporting members inside the existing building bolted to the existing floor slab and exterior wall.



All photos this page by CORE



▼ The terra-cotta-clad addition connected to the existing building via a steel-framed atrium.

- ▲ The existing building and addition are brought together by a metal-clad canopy and glazed atrium.
- ▼ A detail of the connection between the skylight and the building.

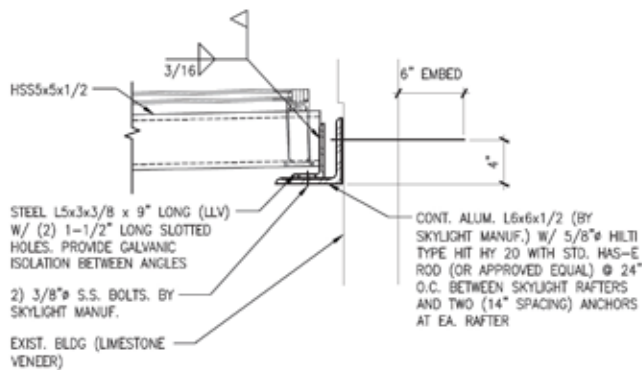

**3 STRUCTURAL DETAIL: SKYLIGHT TO EXISTING BUILDING**  
NOT TO SCALE



the colors and shades of the existing limestone and the terra-cotta roof as they move up the side of the new building. This terra-cotta screen extends over the roofline to become an architectural screen for the rooftop equipment supported by galvanized HSS framing that bears down on the structural frame. The effect is that the building uniquely appears to be a monolithic structure without exposing the mechanical equipment on the rooftop.

The existing building has been completely opened up to use as much space as possible for reading rooms and stacks. The terrace level was not originally used for reading rooms, but has been transformed into a space for teens and adults to read and study. The first floor has been renovated and restored to bring back its original grandeur, while on the third floor the staff spaces were relocated to the addition to allow the children's space to expand over the entire floor. Originally, an opening through all three floors allowed a cast-iron stack system to be inserted. Although unique, the system did not meet current library functions or building codes and had to be removed. New W12x19 supporting beams were stitched into the existing structure to support the new floors and allow for a code-compliant egress stair and more reading room space.

During construction, challenges in dealing with an existing building and a tight site required additional coordination to bring everything together between the architect, structural engineer and steel fabricator/erector, Crystal Steel Fabricators, Inc. Numerous on-site visits were required by the team to reconcile existing floor elevations with the new structure at all three floors. The visits helped ensure that the expansion

joint between the two buildings performed flawlessly, and also helped develop solutions to challenges such as how to route electrical through to glass handrail systems while preserving the airy glass look and feel in the atrium.

Designed to LEED Gold standards, the new library has continued to be a jewel in and for the neighborhood. The renovation and addition have increased the area of the building from 18,000 sq. ft to 25,000 sq. ft and more importantly, the usable areas to the public have increased from 65% of the old building to 80% of the new building. Although filled with challenges due to an oddly shaped site, an active and engaged community, numerous required agency reviews, a unique cladding system and a tightly designed framing system, these elements combine to create a library for the 21st century that acknowledges and embraces its grand historic past and complements its future with a modern addition. ■

**Owner**

District of Columbia Public Library

**Construction Manager**

Smoot Construction

**Architect**

CORE and HMA2

**Structural Engineer**

ReStl Designers, Inc.

**Steel Fabricator, Erector and Detailer**

Crystal Steel Fabricators, Inc., Delmar, Del. (AISC Member/AISC Certified Fabricator)