

Technology, MEET Constructability

BY DAVE RUBY, SE, PE

The second installment of the “But It Worked in the Model!” series serves as a cautionary tale about the overdependence on technology and the underestimation of constructability factors.

TODAY’S SUCCESSFUL DESIGN-BUILD TEAMS, composed of experienced designers and knowledgeable construction professionals, collaboratively develop designs based on two major ideas.

The first is the concept of constructability, or the infusion of construction knowledge and experience into planning, design, procurement and field operations to achieve overall project objectives. The second is the use of advanced technology or enhanced data-based models, virtual construction and project planning.

Technology has improved efficiency in design, enhanced document production and allowed structures that were beyond our imagination just a few short years ago to be built. However, in the design development process, the lateral load path or boundary conditions assumed during the early phase of concept development may go undetected during analysis modeling—and then may not be properly identified within the final design documents or model. The oversight may go unnoticed during the bidding and fabrication processes and subsequently may lead to lateral instability of the structure during construction.

A Case of Omission

With these concepts and culture in mind—this “silo-less” environment—and with the hope that collaborative, constructability-infused design will soon become the standard for the design community, let’s explore a recent project, which included an undefined lateral-load-resisting system. This was compounded by a detailer’s poor execution during shop drawing

preparation, a subsequent structural engineer of record’s inadequate approval process and finally lack of a site-specific erection procedure, ultimately resulting in a building failure.

Our example begins with a single-story flat roof structure with an open-web steel joist roof and reinforced masonry shear walls (Figure 1). The building is architecturally enhanced by a dome roof structure above the lobby (Figure 2). The structural design documents presented the framing as rather simple with no obvious signs of complexity. However, the design documents did not contain critical information about the structure’s stability requirements. As noted in the AISC *Code of Standard Practice for Steel Buildings and Bridges*, ANSI/AISC 303-16 (available at www.aisc.org/standards): “The owner’s designated representative for design shall identify the following in the contract documents: (a) The lateral-load-resisting system and connection diaphragm elements that provide for lateral strength and stability in the completed structure.”

The design documents did not note the interaction of the reinforced masonry shear walls with the metal deck roof diaphragm, nor did they identify the structural interdependence of the dome’s tension and compression rings. In addition, the documents did not identify the interdependence of the structural steel and nonstructural steel elements of the lateral-load-resisting system. The initial design and modeling of the structure may have produced a conclusive result, confirming the strength and stability of the design concept. However, the design documents/model failed to communicate the nature of the structure to the fabricator and erector.

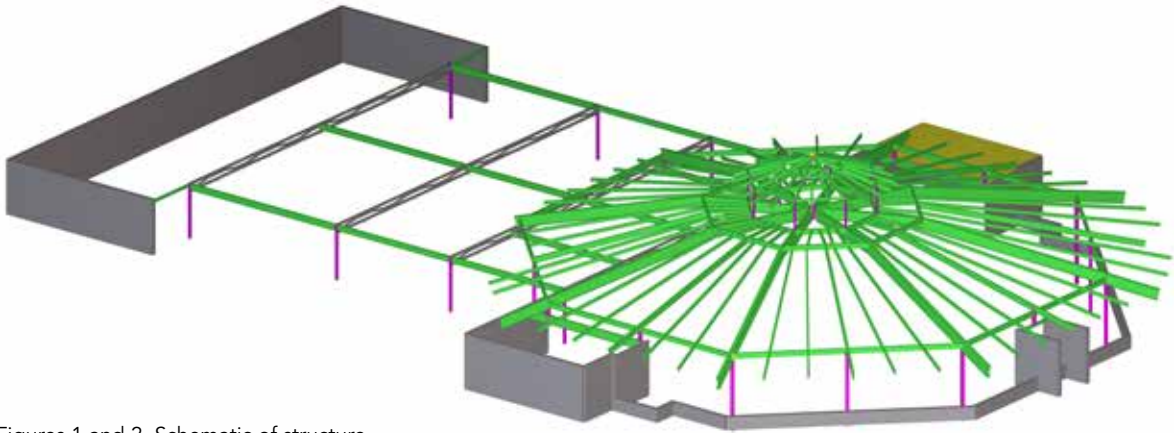

▶ Figures 1 and 2. Schematic of structure and dome with tension and compression rings.

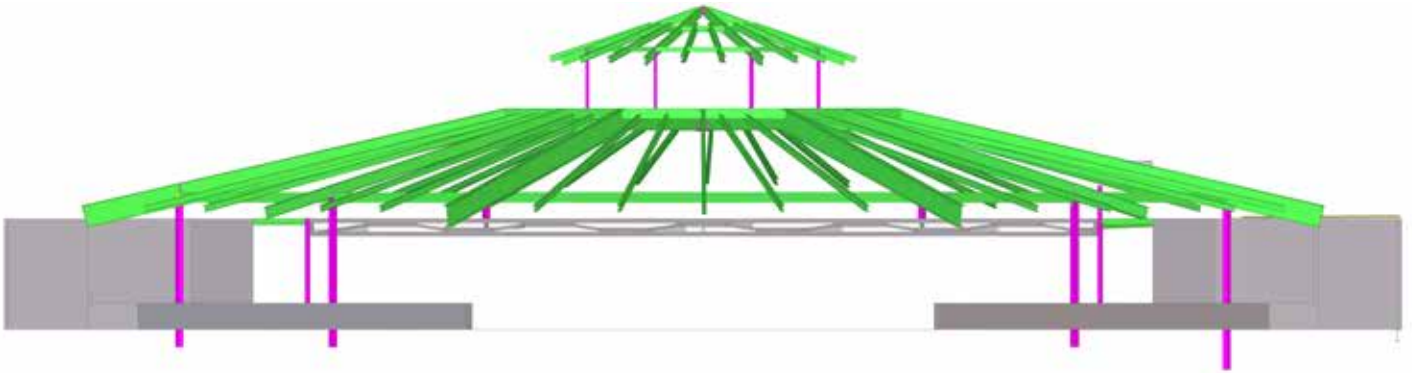

▲ Figure 3. The tension ring after initial failure.

With the majority of the structural steel in place, the roof joists installed and installation of the metal deck on the flat roof portion of the structure nearing completion, a sudden breach of the dome tension ring precipitated a partial collapse of the structure (Figure 3). At the time of the collapse, the majority of the flat roof and dome structural elements were in position but not fully connected. Tension ring members were tack-welded in position, ties to the supporting shear walls were incomplete or nonexistent and the lateral-load-resisting flat roof diaphragm was not attached to the exterior shear walls. Thus, the lateral-load-resisting system did not exist. The owner and the contractors were perplexed, and in this case the structural engineer of record's response was, "But it worked in the model!"

Dave Ruby (druby@rubyandassociates.com) is the chairman and founding principal of Ruby+Associates Structural Engineers in Bingham Farms, Mich.



What Went Wrong?

Several issues were revealed following the failure. First, the engineer neglected to define the nature of the structure or to describe the lateral-load-resisting system or the importance of the interface between its structural steel and nonstructural steel elements.

Second, the fabrication and erection contracts were executed separately by the construction manager, a relationship that can result in limited communication between the fabricator and erector. In this case, there was no evidence of discussion between the two related to the installation or stability of the structure.

Third, the delegated connection design was performed by the fabricator's in-house detailer. The in-house detailer apparently developed the field connection details without considering the dome's tension/compression system stability requirements (unidentified by the contract documents), without regard for stability and without input from the erector.

Fourth, in the absence of information related to the nature of the structure, the fabricator and erector proceeded without an understanding of the structural concept, the importance of the lateral-load-resisting system and the continuity of the tension ring elements in maintaining the stability of the dome

structure. Had the fabricator or erector understood the nature of the structure and its lateral stability requirements, substantial initial connections of the diaphragm and tension ring would have been completed upon installation.

Fifth, the erector accepted the fabricator's tension ring connection detail and deemed the temporary tack weld of the tension ring connections to be adequate (Figures 4 and 5). And without direction otherwise, as to be expected in the field, the dome was erected.

Lastly, the structural engineer's approval process was somewhat dubious. Inconsistencies exist when comparing the erection documents to the contract documents. Figure 6a depicts the design detail for the connection of the metal roof deck diaphragm to the shear wall. As we know, this detail is critical to the lateral stability, since the deck acts as the primary diaphragm element for the structure.

Critical Connections

The photograph of the as-built connection after the collapse shows a separation between the wall and the roof deck (Figure 6b). This design detail was not included in the metal deck or structural steel installation drawings as submitted by the fabricator.

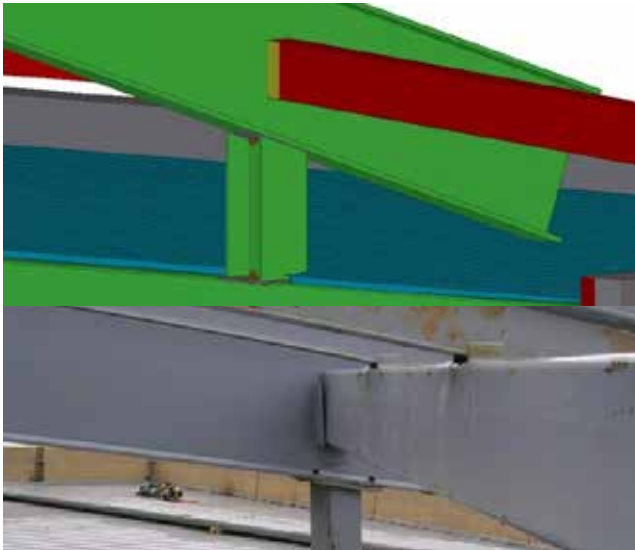

▲ Figure 4. W16x31 rafter frames into column with welded tube connections on both sides (model above, field below).

▼ Figure 5. Typical tube connection for W30x108 rafter.

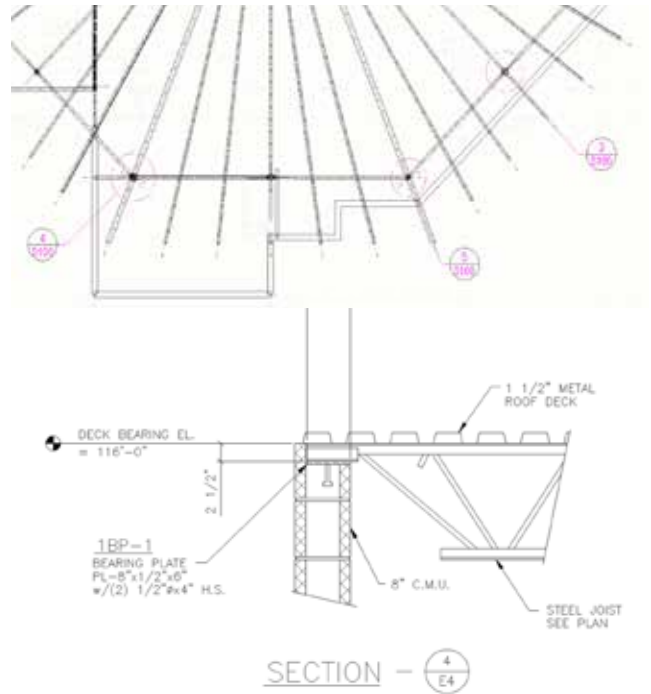
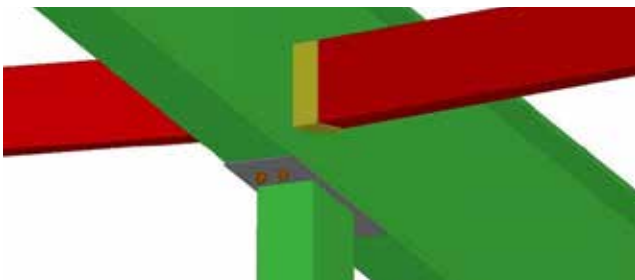

▲ Figure 6a. Details from the erection drawings.

▼ Figure 6b. Separation between wall and roof deck.



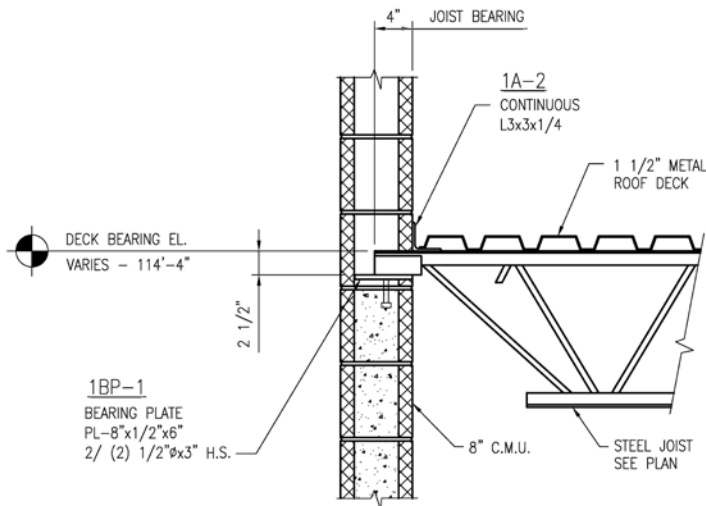

▲ Figure 7a. Detail from the erection drawing.

▲ Figure 7b. As-built construction.

Similarly, the detail (Figure 7a) depicts a continuous angle spanning the length of the wall connecting the roof deck to the shear wall and effectively completing the diaphragm. Once again, the photograph (Figure 7b) displays the absence of any such connection, as light can be seen pouring through the gap between the deck and wall. Though each case admittedly displays a lack of quality control and poor construction practice, an overriding concern is the lack of a thorough shop drawing approval by the structural engineer and an apparent disregard for the importance of the metal deck connection in effectively distributing the lateral load to the shear walls.

In addition, note the stub in Figure 7b, which shows a support post for the dome roof structure that translated during the collapse. The dome rested on short posts without any provision for lateral load transfer to the metal deck diaphragm or subsequently to the reinforced masonry shear walls. All the components were there in some fashion, but the interdependence on the structural steel and nonstructural steel elements were totally undefined in the contract documents and therefore did not become an integral part of the installation documents.

Lessons Learned

Structural engineering professionals design structures that are stable upon completion. Their analysis and design model includes defined boundary conditions and a lateral-load-resisting system that is communicated to the contractor within the design documents. In our example, the engineer not only failed to communicate the nature of the structure, the essence of the lateral-load-resisting system and the interrelationship of various elements and materials necessary for structural stability, but based on their approval process it is likely that they also didn't comprehend the nature of the structure or the necessary interrelationship of the various elements.

At times, the contractor, fabricator and erector may have experience that indicates something may be missing from design drawings. But in our competitive, low-bid environment, there is little incentive for a contractor to voluntarily fill in gaps within design documents. The contractor is better served by raising

questions of concern during the bid clarification process, thus ensuring that all bidders are made aware of the potential issue. In this case however, the contractor proceeded, assuming that the structural engineer's design model and related design documents were accurate and complete.

The AISC *Code* states, in Section 3.1.4 and Section 7.10.1 (a):

3.1.4. When the structural steel frame, in the completely erected and fully connected state, requires interaction with nonstructural steel elements (see Section 2) for strength and/or stability, those nonstructural steel elements shall be identified in the *contract documents* as required in Section 7.10.

7.10.1. The owner's designated representative for design shall identify the following in the contract documents:

(a) The lateral-load-resisting system and connecting diaphragm elements that provide for lateral strength and stability in the completed structure.

Had the structural engineer for this particular project complied with the *Code* and had this information been included in the contract documents, would the failure have occurred? Most likely not.

With any project and in general, it is important to recognize the significance of even the most mundane tasks, amplify the need to share knowledge and experience and encourage the development of a collaborative relationship within the design and construction communities. Let's abandon our silos and actively share our knowledge. Too often we find the source of project problems stem from incomplete communication related to the structural concept, a misunderstanding of the boundary conditions or simply an undefined load path. These are the elements of design that must be communicated. When we neglect to share our knowledge, we are forfeiting our most powerful tool as engineers and ultimately compromising the value of our work. ■

See Dave Ruby's first "But It Worked in the Model!" article in the April issue, available at www.modernsteel.com.