

# Modern Steel Construction

December 2020

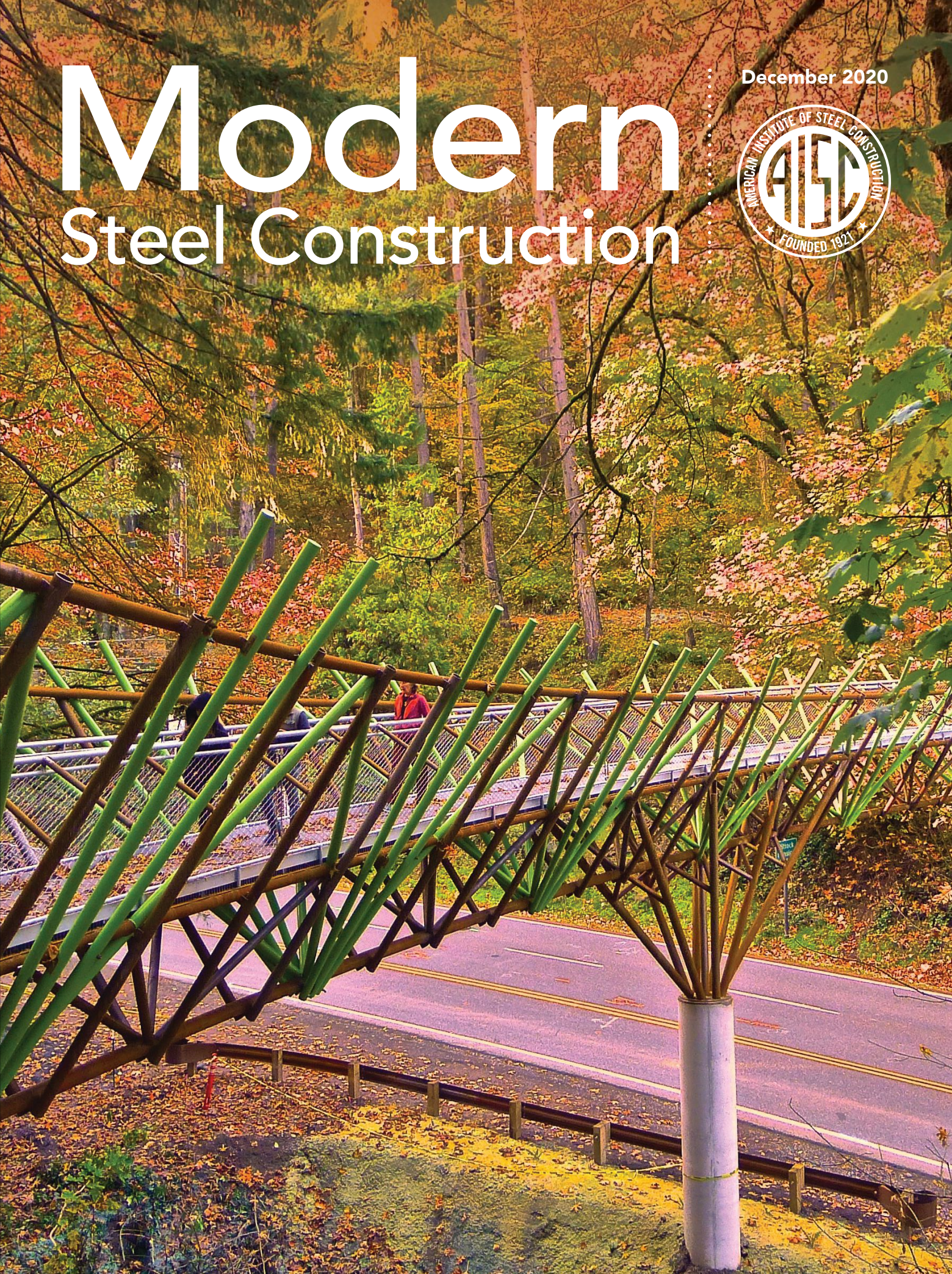



# HIGH SPEED ROBOTIC

## STEEL BEAM ASSEMBLY

- Accomplishes work of 5 fitters per shift
- Maintains 1/24" accuracy over 60' profiles
- Fit and tack pieces at 1.5 minutes per part

[www.peddinghaus.com/steel/assembler](http://www.peddinghaus.com/steel/assembler)



THE  
PEDDIASSEMBLER

**Peddinghaus**

**STRONGER** THAN  
STEEL®

[www.peddinghaus.com](http://www.peddinghaus.com) | [info@peddinghaus.com](mailto:info@peddinghaus.com) | (815) 937-3800





# Are You Redi...

## GET REDI FOR A SIMPLIFIED, LOW-COST ALTERNATIVE TO CONVENTIONAL CONCRETE CORE CONSTRUCTION.

Conventional methods of concrete and CMU core construction can be a real challenge. Unpredictable weather and unacceptable concrete tolerances often bring production schedules to a screeching halt. And that can be costly.

Now there's a better way.

**RediCor** is a factory-built, ready-to-set modular steel form system that simplifies concrete core construction. The structurally true modules stack like building blocks and are ready for concrete once they're set – saving time and money. So, are you Redi?



Optional preinstalled stairs, embeds and connections improve safety and schedule.

**NUCOR**<sup>®</sup>  
**VULCRAFT**

Powerful Partnerships.  
Powerful Results.

VISIT US AT [REDICOR.COM](http://REDICOR.COM) FOR THE REDICOR STORY.

**REDICOR**<sup>®</sup>  
Modular Steel Form System  
BY VULCRAFT

# Modern Steel Construction

December 2020

## in every issue

### departments

- 6 EDITOR'S NOTE
- 9 STEEL INTERCHANGE
- 12 STEEL QUIZ
- 62 NEWS & EVENTS
- 66 STRUCTURALLY SOUND

### resources

- 64 ADVERTISER INDEX
- 65 MARKETPLACE & EMPLOYMENT

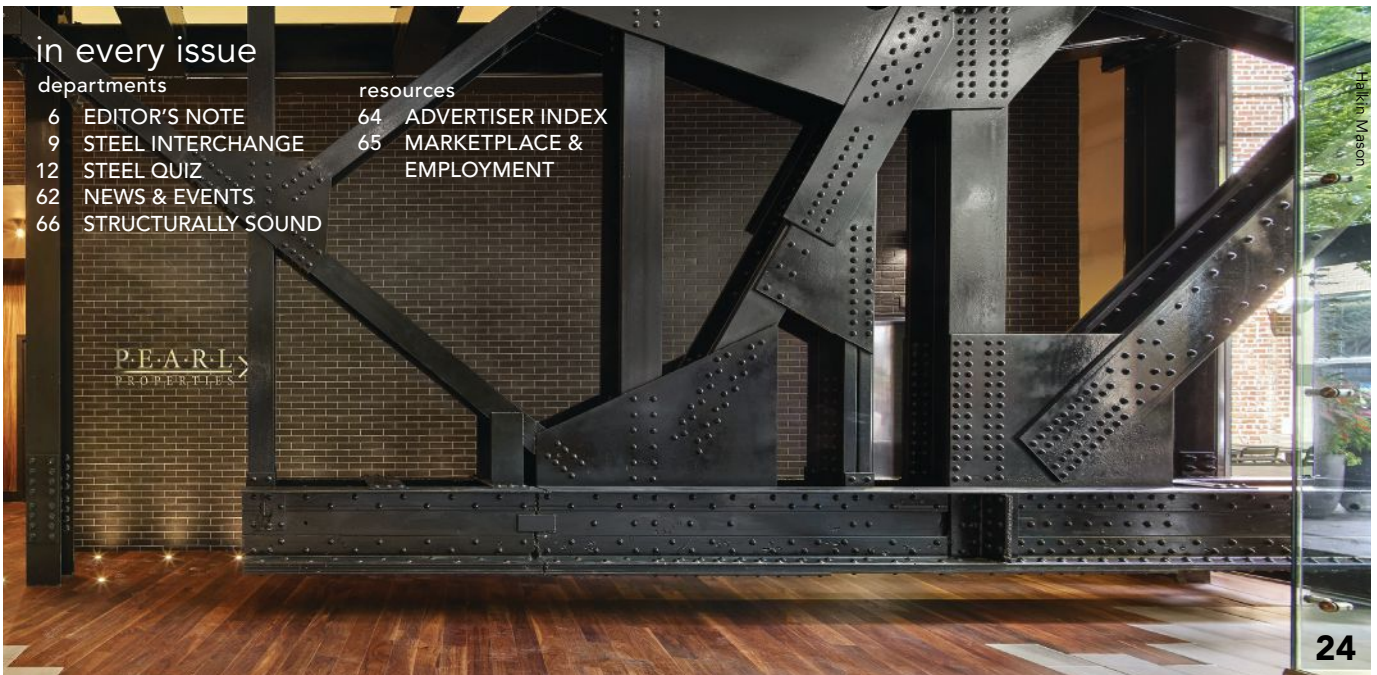

## features

### 24 **What's Cool in Steel**

Every year, *Modern Steel* presents a compendium of fun projects showcasing the cool use of steel. The 2020 list includes a Mississippi facility geared toward maximum entertainment, an Oregon pedestrian bridge that blends in with nature, a striking stage in Iowa's capital city, a Philadelphia high-rise with an attention-commanding truss, and several other attractive steel wonders. And in addition to these recently constructed projects, we're featuring a blast (zone) from the past that demonstrates the staying power of steel.

### 54 **Picturing the Future**

The winners of a student research competition share what they've learned about a variety of steel projects, old and new.

### 58 **Almost There**

BY GEOFF WEISENBERGER

Despite taking place entirely online, SteelDay 2020 sees a big jump in participation from last year.

## columns

### steelwise

### 16 **The Short Shank Redemption**

BY GIAN A. RASSATI, PhD, JAMES A. SWANSON, PhD,  
AND CHAD M. LARSON

Expert advice on bolt design for structural joints.

### field notes

### 20 **Make It Here**

INTERVIEW BY GEOFF WEISENBERGER

Atlas Tube CEO Barry Zekelman doesn't just want you to use American-made steel.

He wants you to use American-made *everything*.

### business issues

### 22 **Connect and Collect**

BY ANNE SCARLETT

Your clients are eager to talk. Now is the time to set up a client perception survey to connect with them and collect their thoughts.

**ON THE COVER:** An Oregon bridge that becomes one with nature is just one of several "What's Cool in Steel" items, p. 24. (Photo: Ed Carpenter)

MODERN STEEL CONSTRUCTION (Volume 60, Number 12) ISSN (print) 0026-8445; ISSN (online) 1945-0737. Published monthly by the American Institute of Steel Construction (AISC), 130 E Randolph Street, Suite 2000, Chicago, IL 60601. Subscriptions: Within the U.S.—single issues \$6.00; 1 year, \$44. Outside the U.S. (Canada and Mexico)—single issues \$9.00; 1 year \$88. Periodicals postage paid at Chicago, IL and at additional mailing offices. Postmaster: Please send address changes to MODERN STEEL CONSTRUCTION, 130 E Randolph Street, Suite 2000, Chicago, IL 60601.

**DISCLAIMER:** AISC does not approve, disapprove, or guarantee the validity or accuracy of any data, claim, or opinion appearing under a byline or obtained or quoted from an acknowledged source. Opinions are those of the writers and AISC is not responsible for any statement made or opinions expressed in MODERN STEEL CONSTRUCTION. All rights reserved. Materials may not be reproduced without written permission, except for noncommercial educational purposes where fewer than 25 photocopies are being reproduced. The AISC and Modern Steel logos are registered trademarks of AISC.



Printed on paper made from a minimum of 10% recycled content.



# Steel Fabricator's Competitive Advantage

## Steel Fabrication Management Software That Can Help You Win More Business

Steel fabricators that use Tekla PowerFab avoid the need to add a margin of error to their competitive bids because they have a high degree of confidence in their cost estimates. PowerFab users are able to submit bids that are as competitive as possible while accurately meeting their desired profit margin.

Don't get left behind, visit [teklapowerfab.com](http://teklapowerfab.com) to learn all the ways Tekla PowerFab can help you increase your competitive advantage including improving bid accuracy.



## editor's note



Just as every kaleidoscope collector knows about Sir David Brewster and every botanist knows of Luther Burbank, everyone who studies data visualization starts with Edward Tufte.

And if you've ever read any of Tufte's books or heard him lecture, he'll almost certainly reference the holy grail of data visualization, *Minard's Map of Napoleon's March on Moscow*. The graphic combines data on the size of the French army over time and distance with information on temperature. It shows how Napoleon lost and why we don't all speak French. (If you Google Minard's map, be prepared to spend time marveling over it!)

When done well, data visualization is the perfect illustration of a picture being worth a thousand words. But it's also incredibly difficult to execute well. Fortunately, we don't need to be Minard or Tufte to provide value in our graphics. A great example is on AISC's website at [aisc.org/economics](http://aisc.org/economics). If you visit that page, you can see a producer price index, using Federal Reserve Economic Data, that compares the cost of hot-rolled structural steel, ready-mix concrete, and softwood lumber.

On the surface, the chart is a simple visual reminder that while the price of structural steel has remained remarkably stable for the past decade, concrete has climbed 33%, and wood has risen even more (and also has the most price volatility).

For me, though, the chart has a deeper meaning. For the last three decades, nary a day has gone by when I haven't repeated the mantra: "Least weight does NOT equal least cost." And to understand why this is so, you only need to look at the chart (though an additional chart showing the increase in labor costs would help). Steel material costs remain flat, but labor costs, both for fabrication and

erection, have increased. Where we once touted a one-third rule (material, fabrication, and erection each made up roughly one-third of the cost of steel contract), today the cost of material has a much lower impact.

For designers, this means two things.

First, when you're looking to optimize a design, you shouldn't be optimizing for weight. Instead, you should be looking at things that can reduce the cost of fabrication and erection, such as increasing member sizes to reduce camber, considering doublers, and adding stiffener plates.

And second, and even more importantly, you should be thinking about your fabricator as a partner and not simply a contractor. By bringing a fabricator on board early in the design process and asking for their advice, you can truly optimize your design to reduce the overall cost rather than just cutting weight and calling it a day.

Fortunately, there are many resources available to help. *Modern Steel Construction* ([www.modernsteel.com](http://www.modernsteel.com)) regularly publishes articles with tips on reducing fabrication costs, and AISC's education archives ([aisc.org/education-archives](http://aisc.org/education-archives)) contain recordings of numerous sessions at NASCC: The Steel Conference with practical advice on optimizing design.

Just keep repeating my mantra, and we'll all have better designs.

  
Scott Melnick  
Editor

# Modern Steel Construction

## Editorial Offices

130 E Randolph St, Ste 2000  
Chicago, IL 60601  
312.670.2400

## Editorial Contacts

EDITOR AND PUBLISHER

Scott Melnick  
312.670.8314  
[melnick@aisc.org](mailto:melnick@aisc.org)

SENIOR EDITOR

Geoff Weisenberger  
312.670.8316  
[weisenberger@aisc.org](mailto:weisenberger@aisc.org)

DIRECTOR OF PUBLICATIONS

Keith A. Grubb, SE, PE  
312.670.8318  
[grubb@aisc.org](mailto:grubb@aisc.org)

PRODUCTION SPECIALIST

Erika Salisbury  
312.670.5427  
[salisbury@aisc.org](mailto:salisbury@aisc.org)

GRAPHIC DESIGN MANAGER

Kristin Hall  
312.670.8313  
[hall@aisc.org](mailto:hall@aisc.org)

## AISC Officers

CHAIR

Jack Klump, Cianbro Fabrication & Coating Corporation

VICE CHAIR

Stephen Knitter  
Geiger & Peters, Inc.

SECRETARY/LEGAL COUNSEL

Edward Seglias, Cohen Seglias  
Pallas Greenhall & Furman, PC

PRESIDENT

Charles J. Carter, SE, PE, PhD

SENIOR VICE PRESIDENT

Scott Melnick

VICE PRESIDENT

Carly Hurd

VICE PRESIDENT

Lawrence F. Kruth, PE

VICE PRESIDENT

Brian Raff

VICE PRESIDENT

Mark W. Trimble, PE

## Editorial Advisory Panel

Caroline R. Bennett, PE, PhD  
University of Kansas

Amanda Dean, PE

Walter P Moore

Bryan Frazier,

Zalk Josephs Fabricators, LLC

Keith R. Griesing, PE

Hardesty and Hanover

Stephen Knitter

Geiger & Peters, Inc.

## Advertising Sales

M.J. Mrvica Associates, Inc.

2 W Taunton Avenue

Berlin, NJ 08009

856.768.9360

[mjmrivica@mrivica.com](mailto:mjmrivica@mrivica.com)

## Address Changes and Subscription Concerns

312.670.2401  
[subscriptions@aisc.org](mailto:subscriptions@aisc.org)

## Reprints

Erika Salisbury

312.670.5427

[salisbury@aisc.org](mailto:salisbury@aisc.org)



100 percent **reliable** so you  
can be 100 percent **accurate**.



SDS/2 customer Joe Bintner, Detailer at  
Drake-Williams Steel in Omaha, NE.

**SDS/2 Estimodeling** is the only software on the market to provide automatic connections for estimates without relying on third-party software. Generate fast and accurate model-based estimates for cost-optimized fabrication and get a jumpstart on project detailing.

Learn how Drake-Williams Steel is making smarter bids and winning more projects with SDS/2 Estimodeling at [SDS2.com/Drake-Williams](https://SDS2.com/Drake-Williams).



A NEMETSCHEK COMPANY



# Digital Manual Sale!

## Get 50% Off a One-Year Subscription



Need a convenient supplement to your paper copy of the *Steel Construction Manual*? We're currently offering a one-year digital subscription of the 15th Edition *Steel Construction Manual* (through December 31, 2021!) for 50% off! This online product provides the entire contents of the *Manual*, including the most recent revisions, and can be accessed from anywhere with an internet connection.

### Features include:

- Access with your AISC username and password from anywhere with an internet connection
- Completely web-based using HTML 5—no plug-ins or software to install
- Embedded hyperlinks for references
- Detailed table of contents
- Fully text searchable
- Reproduces the print edition exactly:
  - Tables appear in aligned, two-page spreads
  - Equations appear exactly as shown in the *Manual*

[aisc.org/publications](http://aisc.org/publications)



**Smarter. Stronger. Steel.**

American Institute of Steel Construction  
312.670.2400 | [www.aisc.org](http://www.aisc.org)



If you've ever asked yourself "Why?" about something related to structural steel design or construction,

*Modern Steel's* monthly Steel Interchange is for you!

Send your questions or comments to [solutions@aisc.org](mailto:solutions@aisc.org).

## steel interchange

All mentioned AISC codes and standards, unless noted otherwise, refer to the current version and are available at [aisc.org/specifications](http://aisc.org/specifications). You can find any referenced Modern Steel Construction articles at [www.modernsteel.com](http://www.modernsteel.com).

### Evaluating a Floor System Designed in 1913

We are currently working on a renovation project where we would like to determine the strength of an existing floor beam (see Figure 1). The structure was originally designed in 1913. According to the original design drawings, the beams are encased in concrete, and there appears to be a wire passing through the beam web and embedded in the slab. Are you familiar with this type of framing?

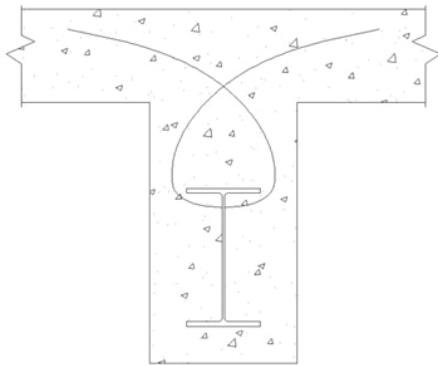

Fig. 1.

I think you may have "System M" by the Standard Concrete Steel Company of New York City as described on page 19 of *Comparison of Various Floor Systems in Reinforced Concrete* by Wolfe & Wiersema, dated 1913. That document is available as a free PDF from the Illinois Digital Environment for Access to Learning and Scholarship via [tinyurl.com/systemmstandardco](http://tinyurl.com/systemmstandardco).

In addition, a Google search for "standard concrete steel company" "system M" brings up some further information.

Larry Muir, PE

### Fatigue in Weld Metal

The number of cases in Appendix 3 of the AISC Specification for Structural Steel Buildings (ANSI/AISC 360) examining fatigue in the weld metal is limited. Where can I find more information on checking fatigue in weld the metal?

A great resource to learn more about fatigue and weld metal is the International Institute of Welding's report *Recommendations for Fatigue Design of Welded Joints and Components*, which can be accessed at [tinyurl.com/fatdesweldrecs](http://tinyurl.com/fatdesweldrecs).

As for the Specification, there are a few cases in Appendix 3 (in Sections 3 and 5) that apply to fatigue in the weld metal, though most cases address fatigue cracks in the base metal. The overwhelming majority of fatigue research has been devoted to base metal cracks, which are critical in most practical cases. However, fatigue cracks can also initiate and grow in the weld metal.

The fatigue performance of any steel element is dependent on several factors, including material toughness, residual stresses, transverse constraint, and the stress concentrations caused by geometric discontinuities. Because the equations in Appendix 3 are empirical, they should be used only for the conditions for which they were developed.

Another design method, the hot-spot method, has been developed for calculating fatigue performance of configurations that do not have experimental testing available. For this method, a single master curve is used. The master curve considers all variables except geometric discontinuities. However, either equations or finite models must determine the stress concentrations caused by the geometric discontinuities.

Bo Dowsell, PE, PhD

### Prying Check Methods

In AISC Design Example II.A-1B, "All-Bolted Double-Angle Connection Subject to Axial and Shear Loading" (in *Companion to the AISC Steel Construction Manual, Volume 1: Design Examples*, available at [aisc.org/15.1-design-examples-voll](http://aisc.org/15.1-design-examples-voll)), the prying is checked using Equations 9-26 and 9-27 in the AISC Steel Construction Manual. I was wondering if I could have used Equation 9-19 instead?

Yes, a designer can approach the prying action analysis either way. Regarding the use of Equations 9-26 and 9-27, the text states: "Alternatively, when the fitting geometry is known, the available tensile strength per bolt,  $B_c$ , determined per AISC Specification Sections J3.6 or J3.7, is multiplied by  $Q$  to determine the available tensile strength including the effects of prying action,  $T_c$ ..."

Equation 9-26, in combination with Equation 9-27, allows the designer to use known geometry, using the available tensile strength of the bolts due to combined tension and shear.

If you are interested in learning more about prying action, a great resource is the July 2016 *Modern Steel* article "A Quick Look at Prying." In addition, a more in-depth version of this article is available at [aisc.org/pryingcheck](http://aisc.org/pryingcheck).

Jennifer Traut-Todaro, SE





**Carlo Lini** ([lini@aisc.org](mailto:lini@aisc.org)) is AISC's director of technical assistance, and **Jennifer Traut-Todaro** ([traut-todaro@aisc.org](mailto:traut-todaro@aisc.org)) is a senior staff engineer with AISC's Steel Solutions Center. **Bo Dowswell**, principal with ARC International, LLC, and **Larry Muir** are both consultants to AISC.



**STEEL SOLUTIONS CENTER**

Steel Interchange is a forum to exchange useful and practical professional ideas and information on all phases of steel building and bridge construction. Contact Steel Interchange with questions or responses via AISC's Steel Solutions Center: 866.ASK.AISC | [solutions@aisc.org](mailto:solutions@aisc.org)

The opinions expressed in Steel Interchange do not necessarily represent an official position of the American Institute of Steel Construction and have not been reviewed. It is recognized that the design of structures is within the scope and expertise of a competent licensed structural engineer, architect or other licensed professional for the application of principles to a particular structure.

The complete collection of Steel Interchange questions and answers is available online at [www.modernsteel.com](http://www.modernsteel.com).

## Slip-Critical in Bolted Moment Connections

**Does the AISC Specification require that bolted moment connections be made slip-critical?**

The AISC *Specification* does not require the use of slip-critical connections for moment connections, and the AISC *Steel Construction Manual* does not recommend the use of slip-critical connections for moment connections.

One typical configuration of field-bolted moment connections is the bolted flange plate. Due to the flange tilt tolerance on the column, it is common (in my experience) for fabricators and erectors to prefer oversized holes for these connections—and for this use of oversized holes to lead to using slip-critical connections. However, it should be understood that there is no requirement to use oversized holes for bolted flange plate moment connections; it is simply a common preference in our industry.

*Larry Muir, PE*

## Slip-Critical in Welded Moment Connections

**I am designing a moment connection where the beam flanges are welded to the support. Does the bolted connection to the beam web need to be made slip-critical?**

The May 2012 *Modern Steel Construction* SteelWise article “Developing  $M_p$ ” states: “A common misconception is that slip-critical joints are necessary at the web connection to limit the vertical movement of the beam after the flanges have been welded. This would presumably prevent secondary bending and shear stresses in the beam flange in the area between the column flange and the weld access hole. However, the tests showed no decrease in strength when bearing joints were used. Furthermore, most of the tests with slip-critical joints had slip occur at some point in the testing, effectively rendering the web connection a bearing joint anyway.”

There is no requirement, or even recommendation, in the AISC *Specification* or *Manual* to use a slip-critical connection at the web of moment connections.

*Larry Muir, PE*

## Fillet Welds Placed Over Gaps

**I am designing a weld between a slotted HSS brace and a gusset plate. The weld size required for strength is  $\frac{5}{16}$  in. There will likely be a gap between the HSS material and the gusset plate for fit-up purposes. Should I increase the size of the fillet weld to account for the possibility of a gap?**

No. The design documents should only show the weld size required for strength, as addressed in Clause 4.3.4 of AWS D1.1/D1.1M:2020: *Structural Welding Code—Steel*. The shop drawings will address adjustments to the required fillet weld size based on the effects of joint geometry as required in Clause 4.3.5.2. Clause 7.22.1 permits a root opening not larger than  $\frac{3}{16}$  in. ( $\frac{5}{16}$  in. in some cases) as long as the leg of the fillet weld is increased by the amount of the root opening. So if a  $\frac{5}{16}$ -in. fillet weld is required in the design documents and a gap of  $\frac{1}{8}$  in. exists between the HSS wall and gusset plate prior to welding, then a  $\frac{7}{16}$ -in. fillet weld would need to be placed or the contractor would need to demonstrate that the required effective throat has been obtained. Note that for gaps less than or equal to  $\frac{1}{16}$  in., no adjustment to the fillet weld leg size is necessary.

*Carlo Lini, PE*



# A WORLD OF STEEL PROCESSING MACHINERY...

## The Solution That Best Fits Your Needs.



BEAM  
PROCESSING



**EXCALIBUR - VICTORY**  
Mono spindle CNC  
Horizontal Drilling Systems



**ORIENT range**  
Mono spindle CNC  
Profile Processing Center



**VANGUARD range**  
Three spindle CNC Profile  
Processing Lines



**LIBERTY range**  
Three spindle CNC  
Profile Processing Lines



**ENDEAVOUR - VALIANT range**  
Three spindle CNC Profile  
Processing Lines



**ENTERPRISE range**  
CNC Gantry Drilling Lines



**RAZ - FLEX range**  
CNC Coping Robot and Systems



**KATANA range**  
Band Sawing Systems



PLATE  
PROCESSING



**P range**  
CNC Punching, Drilling  
and Marking Systems



**TIPO D range**  
CNC Punching, Drilling  
and Cutting Lines



**KRONOS range**  
CNC High definition Plasma  
and Oxy Cutting Systems



**GEMINI range**  
CNC Drilling, Milling  
and Thermal Cutting Systems



**TIPO G range**  
CNC Drilling, Marking and  
Thermal Cutting Systems



**TIPO B range**  
CNC Punching, Marking and  
Thermal Cutting Systems



**TIPO C range**  
CNC Punching, Drilling and  
Thermal Cutting Systems



ANGLE  
AND FLAT  
PROCESSING



**A range**  
CNC Punching, Drilling,  
Marking and Shearing Systems



**SP range**  
Super Performance  
CNC Punching and Shearing Systems



**HP range**  
CNC Punching, Drilling, Notching,  
Marking and Shearing Systems



**XP range**  
High performance CNC Punching  
and Shearing Lines



**RAPID range**  
CNC Drilling, Marking  
and Cutting Systems



SURFACE  
TREATMENT



**Shot blasting System**  
Surface treatment systems

A drive to constantly improve, to meet increased demands for higher efficiency and throughput, has made FICEP a global leader for the past 88 years.

Don't just take our word, ask our customers... FICEP equipment owners have seen the results, with unmatched reliability and increased productivity.

Call and let us show you solutions designed specifically for your operation.



**FICEP Corporation**  
2301 Industry Court, Forest Hill, Maryland 21050  
Phone (410) 588-5800  
Fax (410) 588-5900

[www.ficepcorp.com](http://www.ficepcorp.com)

As a fabricator, time is money, and the margin for errors is non-existent. FICEP Corp. understands and is prepared to help you achieve higher through-put with greater control and precision.

Contact us for solutions that increase your productivity, and join fabricators across the globe who trust the world's leader in steel processing equipment.



# steel quiz

This past summer, the American Institute of Architects (AIA) and AISC collaborated on and published the white paper *Design Collaboration on Construction Projects Part I: Delegated Design, Design Assist, and Informal Involvement—what does it all mean?* Available at [aisc.org/design-collaboration-iaa](http://aisc.org/design-collaboration-iaa), it provides the answers to this month's Steel Quiz.

TURN TO PAGE 14 FOR THE ANSWERS

## GET CONNECTED WITH LNA SOLUTIONS

- **CLAMPS DIRECTLY TO EXISTING STRUCTURES**
- **EASY INSTALLATION**
- **HOT-DIP GALVANIZED**
- **NO DRILLING**
- **GUARANTEED LOADING + FACTOR OF SAFETY**
- **NO WELDING**



LNA SOLUTIONS  
A KEE SAFETY COMPANY

LNA Solutions, Inc. | Buffalo, New York | (888) 724 2323  
email: [inquiries@LNASolutions.com](mailto:inquiries@LNASolutions.com) | [www.LNASolutions.com](http://www.LNASolutions.com)

- 1 True or False:** The three collaborative techniques discussed in the paper—delegated design, design-assist, and informal involvement—are considered alternatives to the design-build project delivery method.
- 2 True or False:** Only one of the stated techniques can be implemented at a time on a given project.
- 3 True or False:** Architects must collaborate only with construction managers, who in turn collaborate with specialty contractors and product manufacturers.
- 4** During informal involvement collaboration, which of the following is *not* an example of a matter on which the contractor may advise the design professional?
  - a. Cost estimates for portions of the work
  - b. Modification suggestions for the specifications
  - c. Constructability of a design element
  - d. Production schedules
- 5** The goal of design-assist as a project delivery method is to provide contractors the opportunity to:
  - a. Suggest modifications while the design is being developed
  - b. Dictate all aspects of the design
  - c. Rework design elements following the design stage
  - d. All of the above
- 6 True or False:** During delegated design collaboration, the contractor assumes responsibility for developing design details and the governing performance criteria.



# Scooping up the PDHs

## AISC Continuing Education

### Live Webinars

December 10

Design of Strengthening for Existing Steel Members

Presented by Joseph S. Schuster, SE, PE

1:30 – 3:00 p.m. ET | 1.5 PDHs

[aisc.org/webinars](https://aisc.org/webinars)

### Education Archives

Did you know that AISC offers 30-minute to 6-hour presentations on demand? Viewing is free—so grab some hot chocolate (extra marshmallows!) and check them out!

And if PDHs are what you're after, you can purchase, take, and pass a quiz to earn a certificate. There are over 200 hours of options to choose from.

[aisc.org/educationarchives](https://aisc.org/educationarchives)



**Smarter. Stronger. Steel.**

American Institute of Steel Construction  
312.670.2400 | [www.aisc.org](http://www.aisc.org)



- 1 **False.** Footnote 4 clarifies this: "The design collaboration techniques discussed in this paper should not be confused with the design-build project delivery method. Design-build describes a contractual structure in which the owner hires one entity, a design-builder, to be responsible for both the design and construction of a project. The design collaboration techniques discussed herein can be used in a design-build scenario as the design professionals in a design-build project are often sub-consultants to the design-build entity, resulting in the same issues that make design collaboration appealing in other delivery methods."
- 2 **False.** Any project may employ more than one of these collaborative techniques at a time. When project collaboration includes some level of reliance on information or services provided or some level of design delegation, it is critically important to the project's success that the responsibilities of all parties involved in the collaboration are clearly stated in the contract documents.
- 3 **False.** It can be just as important for architects to collaborate directly with specialty contractors and product manufacturers.
- 4 **b.** "Modification suggestions for the specifications" is not an example of informal involvement but rather an example of a design-assist service provided by the contractor.
- 5 **a.** The goal of design-assist is to provide contractors with an opportunity to suggest modifications to design elements while the design is still being developed.
- 6 **False.** The design team is responsible for the adequacy of the performance criteria. The contractor is responsible for achieving the portion of the design delegated and may incur liability for this portion, as well as assume professional design responsibility and liability for its design.



**STEEL SOLUTIONS CENTER**

Everyone is welcome to submit questions and answers for the Steel Quiz. If you are interested in submitting one question or an entire quiz, contact AISC's Steel Solutions Center at 866.ASK.AISC or [solutions@aisc.org](mailto:solutions@aisc.org).

# Handrail? Easy.



## CNC Plasma Tube & Pipe Processing Machine



- Round: 0.75" - 6"
- Square/rectangle/channel/angle: 0.75" - 4"
- Material length up to 24'



Bend-Tech Dragon Software imports from Solidworks, Tekla, and other CAD programs.





**1847**

Seneca Falls Convention launches women's suffrage movement.

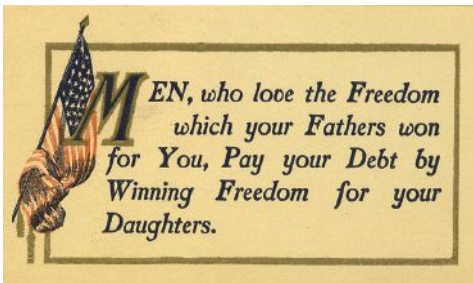

**NINE STEEL BRIDGES**

that are still in service today were open to traffic when it happened.

**5,189 SUCH BRIDGES**

were already open when the Nineteenth Amendment finally granted women the right to vote in 1920.

**1933**

Police drag the Charles River after a "cod-napping" in the Massachusetts State House.

At least

**13,525 STEEL BRIDGES**

that are still in service today were already open to traffic.



Scott D Flickr

**1863**

President Abraham Lincoln delivers the Gettysburg address.

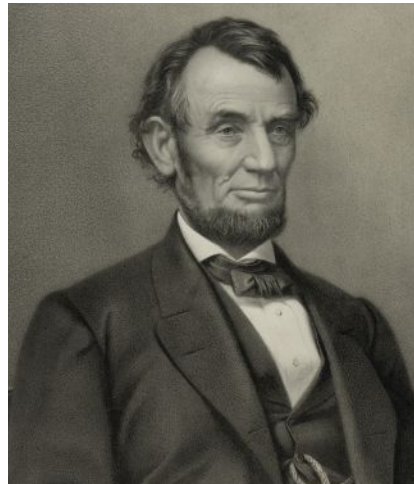

**63 STEEL BRIDGES**

that are still in use today were already open to traffic.

**EVERY DAY IN THE U.S., AN AVERAGE OF 77 MILLION VEHICLES CROSS MORE THAN 25,000 STEEL BRIDGES BUILT BETWEEN 1838 AND 1938.**

These are just a few of the stories these bridges could tell: dazzling innovation, events that changed the world, and quirky people being...well, quirky.

Visit [aisc.org/timeline](http://aisc.org/timeline) for more.



**Smarter. Stronger. Steel.**

National Steel Bridge Alliance  
312.670.2400 | [www.aisc.org](http://www.aisc.org)



# steelwise

## THE SHORT SHANK REDEMPTION

BY GIAN A. RASSATI, PHD,  
JAMES A. SWANSON, PHD, AND  
CHAD M. LARSON



**Gian Andrea Rassati** ([gian.rassati@uc.edu](mailto:gian.rassati@uc.edu)) and **James A. Swanson** ([james.swanson@uc.edu](mailto:james.swanson@uc.edu)) are both associate professors in the College of Engineering and Applied Science at the University of Cincinnati. **Chad M. Larson** ([clarson@lejeunebolt.com](mailto:clarson@lejeunebolt.com)) is president of LeJeune Bolt Company.

Expert advice on bolt design for structural joints.

**MOST BOLTED STEEL STRUCTURES** rely on the predictable transfer of shear load among the steel plies within a given joint through bearing on the structural bolts holding them together.

Bolts loaded in shear are said to “resist” shear in service, and this resistance is established primarily by bolt strength, which is in turn controlled by whether the shear plane intersects the bolt’s threaded section or its body. Of critical importance in design assumptions for these joint types are the locations of the shear planes, which transfer these loads through a combination of material bearing capacity and bolt shear resistance.

Many reading this will already know that the condition where the shear plane intersects the body of the bolt is referred to as “X” (as in threads eXcluded)—and when the shear plane intersects the threaded section of the bolt, the condition is called “N” (threads Not excluded); both conditions are shown in Figure 1. There is a difference in bolt shear area of approximately 20% between the X and N conditions and also, importantly, a corresponding difference in strength.

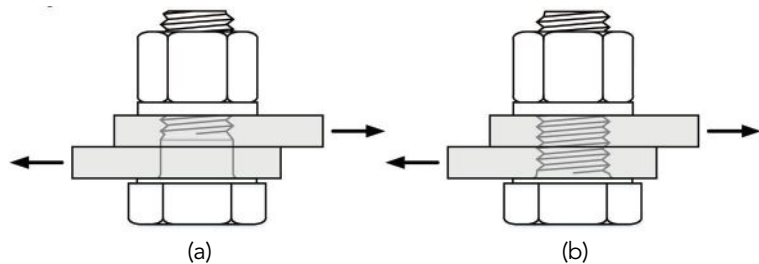

Fig. 1. Shear plane excluded from the threads (a) and not excluded from the threads (b).

Structural bolts are intentionally made with shorter threads than other bolt grades. This geometry is designed to increase the available bolt body length, and therefore increases shear resistance when the design provides shear through the body. As such, it is critical that design considerations and bolt geometry related to shear capacity are in alignment and well understood. A high percentage of structural bolts are relatively short in length and are used to connect relatively thin plies of material, so structural bolt geometry in such cases is particularly important. Key considerations on bolt shear location can be boiled down to a few items:

- the outer ply thickness of the connected material
- the available length of the bolt body
- the bolt orientation within the hole (possibly)

### More Bolts, More Problems

Simple, right?

In theory, yes, though problems can arise. Let’s discuss three of them.

**Problem 1: Manufacturing Bolts.** Bolt manufacturers, as required by standards such as ASTM F3125/F3125M-19e2 and F3148-17a, must adhere to an ASME dimensional standard, namely ASME B18.2.6-19. This ASME standard defines *control dimensions* and *reference dimensions*. The former are those dimensions used during manufacturing to adhere to the standard; the latter are those dimensions provided for information only or for the purpose of calculating a control dimension. This distinction is important but is also one of the sources of confusion. The exact details of the ASME dimensional specification are covered in depth in two *Engineering Journal* papers from earlier this year (see the sidebar) but can be broken down into the following, with reference to the dimensions shown in Figure 2:

- Bolts can be made considerably shorter than the nominal length ( $L$ ).
- The thread transition ( $Y$ ) might use significant length in the region between the threads and the full body length ( $L_B$ ) that is not included as part of the reference thread length.
- Producers are not required to measure thread length ( $L_T$ ). Thread length is a reference dimension and is what remains after the overall length, length of body, and length of grip ( $L_G$ ) dimensions are met.
- When the calculated remaining minimum body length is shorter than a certain multiple of the thread pitch (based on bolt diameter), ASME requires that the bolt be fully threaded. This is misunderstood by many and is in conflict with the reference thread dimension.

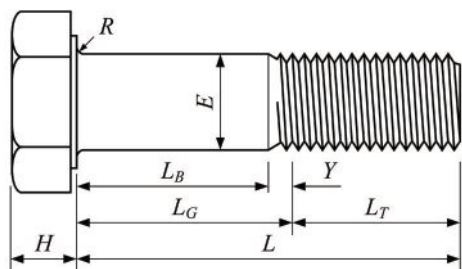

Fig. 2. Dimensions of a heavy-hex bolt, per ASME.

**Problem 2. The transition area between the threads and the body.** Y marks the spot. Structural bolts are commonly cold-formed with rolled threads. This manufacturing process leaves a transition area between the bolt body and the rolled threads. Should we consider this transition area X—or is it N? It is difficult to know the exact dimension, shear mechanism, and strength in this region. The location and length can change between producers or even between bolt production lots. Previous editions of the RCSC *Specification for Structural Joints Using High-Strength Bolts* ([aisc.org/specifications](http://aisc.org/specifications)) have permitted shear in this “thread run out” area to be considered in the X condition, stating that strength loss would be negligible. The mentioned *Engineering Journal* papers have caused a more conservative approach to be taken by RCSC, and the upcoming 2020 edition of the RCSC *Specification Commentary* will treat this transition area as N—i.e., threads not excluded—moving forward.

**Problem 3. Using these dimensions in design.** Where assumptions may not meet reality. Engineers and detailers are familiar with Table 7-14 in the AISC *Steel Construction Manual* ([aisc.org/manual](http://aisc.org/manual)) and Table C-2.1 in the RCSC *Specification*. These tables provide users with numerous dimensions, including a fixed bolt thread length as a function of the bolt diameter. Many engineers and detailers (and likely many design software packages) use one of these tables to determine bolt length based on the grip, and by extension might make assumptions on available bolt body length. Users might take the nominal bolt length ( $L$ ) and subtract the reference thread length ( $L_T$ ), and assume the remaining amount is the available bolt body length. This method can lead to some discrepancies between the calculated (assumed) and the actual available bolt body length.

How different might these dimensions be? Comparing the calculated bolt body length ( $L_B$ ) using Table 7-14 in the AISC *Manual* to the minimum dimensions required in ASME 18.2.6, we can find some notable differences in the presumed length of the bolt body. A comparison is shown in Table 1, below.

Table 1. Comparison of minimum ASME body length with assumed AISC body length.

Nominal Length, $L$	Potential Minimum ASME Body Length vs. Assumed AISC Body Length ( $L_B$ ) in Inches													
	$5/8$ "-11		$3/4$ "-10		$7/8$ "-9		1"-8		$1\ 1/8$ "-7		$1\ 1/4$ "-7		$1\ 1/2$ "-6	
	ASME $L_B$ Min <sup>1</sup>	AISC Table 7-14 <sup>2</sup>	ASME $L_B$ Min <sup>1</sup>	AISC Table 7-14 <sup>2</sup>	ASME $L_B$ Min <sup>1</sup>	AISC Table 7-14 <sup>2</sup>	ASME $L_B$ Min <sup>1</sup>	AISC Table 7-14 <sup>2</sup>	ASME $L_B$ Min <sup>1</sup>	AISC Table 7-14 <sup>2</sup>	ASME $L_B$ Min <sup>1</sup>	AISC Table 7-14 <sup>2</sup>	ASME $L_B$ Min <sup>1</sup>	AISC Table 7-14 <sup>2</sup>
$1\ 1/2$	...	0.25	...	0.125	...	...	...	...	...	...	...	...	...	...
$1\ 3/4$	0.28	0.50	...	0.375	...	0.25	...	...	...	...	...	...	...	...
2	0.53	0.75	0.37	0.625	...	0.50	...	0.25	...	...	...	...	...	...
$2\ 1/4$	0.78	1.00	0.62	0.875	0.47	0.75	...	0.50	...	0.25	...	0.25	...	...
$2\ 1/2$	1.03	1.25	0.87	1.125	0.72	1.00	0.44	0.75	...	0.50	...	0.50	...	0.25
$2\ 3/4$	1.28	1.50	1.12	1.375	0.97	1.25	0.69	1.00	...	0.75	...	0.75	...	0.50
3	1.53	1.75	1.37	1.625	1.22	1.50	0.94	1.25	0.66	1.00	0.62	1.00	...	0.75
$3\ 1/4$	1.78	2.00	1.62	1.875	1.47	1.75	1.19	1.50	0.91	1.25	0.87	1.25	...	1.00
$3\ 1/2$	2.03	2.25	1.87	2.125	1.72	2.00	1.44	1.75	1.16	1.50	1.12	1.50	0.81	1.25
$3\ 3/4$	2.28	2.50	2.12	2.375	1.97	2.25	1.69	2.00	1.41	1.75	1.37	1.75	1.06	1.50
4	2.53	2.75	2.37	2.625	2.22	2.50	1.94	2.25	1.66	2.00	1.62	2.00	1.31	1.75
$4\ 1/4$	2.78	3.00	2.62	2.875	2.47	2.75	2.19	2.50	1.91	2.25	1.87	2.25	1.56	2.00
$4\ 1/2$	3.03	3.25	2.87	3.125	2.72	3.00	2.44	2.75	2.16	2.50	2.12	2.50	1.81	2.25

<sup>1</sup> Potential minimum length of body ( $L_B$ ) per ASME 18.2.6 -19

<sup>2</sup> Calculated length of body ( $L_B$ ) using AISC Table 7-14—Nominal bolt length minus reference thread length

... Fully threaded (although some unthreaded portion under the head, in any configuration, may remain)



As seen in the table, there is a misalignment of expectations. There may be bolts that are expected to have an unthreaded shank but might be fully (or mostly) threaded because of the requirements of ASME. This may lead to cases that are fully compliant with ASME, where the bolt body is not present even though it might be expected based on AISC or RCSC, resulting in a change from the X to the N condition, as shown in Figure 1.

To further add to the confusion, in cases where ASME considers bolts to be “fully threaded,” the unthreaded section under the head of the bolt may be any diameter. Producers may make this short, unthreaded section differently, some using full body diameter, some using pitch diameter, and some using a transition from one to the other. Figure 3 shows three bolts of the same nominal length and diameter ( $\frac{7}{8}$  in. in diameter by 2 in. long), all meeting the ASME standard, having different thread lengths, and all considered fully threaded.



Fig. 3. Three ASME-compliant “fully-threaded” bolts.

Figure 4 shows five bolts of the same nominal length and diameter ( $\frac{7}{8}$  in. in diameter by 2 in. long). Case (a) is provided for comparison purposes and would not meet the ASME standard, while cases (b) through (e) all meet the ASME standard. Figure 4 (a) shows a bolt with a body length with a transition of 0.50 in. and a body diameter of  $\frac{7}{8}$  in. as one might assume from Table 7-14 of the *Manual*; (b) shows a bolt with a body length of 0.22 in. and a body diameter of  $\frac{7}{8}$  in.; (c) shows a bolt with a short body with a diameter of  $\frac{7}{8}$  in. that tapers immediately to the pitch diameter of the threads near the transition; (d) shows a bolt with a body length of 0.22 in. and a body diameter that is approximately equal to the pitch diameter of the threads; and (e) shows a bolt with almost no body whatsoever. Since the bolt is considered to be “short,” ASME would identify each of

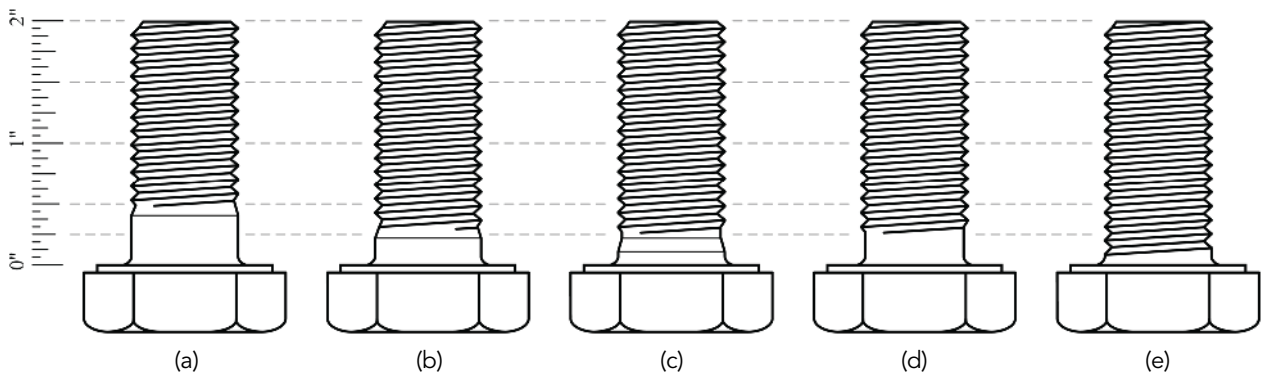

Fig. 4. Different Variations of  $\frac{7}{8}$ -in. by 2-in. ASME-compliant high-strength bolts.

these as a fully threaded bolt. Note that variations in bolt length are also permitted but, for the sake of brevity, are not illustrated in Figure 4. The  $\frac{7}{8}$ -in.-diameter, 2-in.-long bolt has a tolerance on length of +0.00 in. and -0.19 in. The threaded length of the bolt is not a constant, and the negative tolerance on length does not directly affect the minimum body length of the bolt.

### Oh, no! Should X be N?

“OMG, I designed joints with bolts as X (threads excluded), and you’re telling me that I might really have N (threads not excluded)! Is my joint or structure going to fail?”

By now, some might be growing uneasy, thinking of joints that have been designed as if the bolt threads were excluded from the shear plane, and now realizing that those bolts may in fact have threads in the shear plane. Before anyone gets too panicked, there are some considerations on the actual capacity of a bolt in a joint that may allay some anxiety.

First, bolts are rarely manufactured very close to the minimum strength required by their governing ASTM standard. ASTM F3125 Grade A325 and F1852 bolts are nominally made to 120 ksi at a minimum. Based on existing research, the actual material strength of these bolts could be over 140 ksi, a 17% increase from the minimum. The ratio of shear capacity in the N and X conditions is approximately 0.80. Combining the potential bolt overstrength with the decrease in strength from the X to N condition, one arrives at a capacity that could be 93% of the desired value. For Grade A490 and F2280 bolts, the margin of overstrength may not be as large, but in all cases overstrength is potentially significant.

Many readers will recognize that bolts are designed with a resistance factor of 0.75, representing a 25% decrease of the nominal calculated capacity of an individual bolt. The resistance factor theoretically accounts for material strength variability, as well as for the accuracy of the equations used to calculate the nominal strength. It is not correct to just say, “Oh, well. I lose 20% of strength, but I put a 25% hit on that strength to begin with, so I still have a margin.” That margin may be eroded by unknowns against which the resistance factor was intended to guard, but it is not outrageous to think that the strength loss associated with going from the X to the N condition will be mitigated in some significant measure by the resistance factor.

Additionally, the “actual” bolt body length may in fact be greater than the minimum, placing the body of the bolt in shear anyway. The ASME dimensions are minimums, and there is a very real

possibility that the actual bolt body is longer despite the worst-case condition associated with the minimum dimension.

But wait, there's more! A joint will have at least two bolts in it—and it is common for a joint to have tens or even hundreds of bolts. The design equation accounts for the length of a joint decreasing the design shear strength to account for different demands in individual bolts in long connections, and these decreases are often conservative. Additionally, adding a bolt to a connection represents a finite, incremental change in the connection strength that makes it jump by the entire amount associated with the added bolt. For example, if a joint with two bolts did not have quite enough capacity to support a given load, then the addition of a third bolt would provide the desired capacity, plus an excess capacity that might be significant. Rounding up bolt numbers or rows initially could have provided additional capacity.

While the considerations above were made on the resistance side, it is worth considering the demand side. Load factors and load combinations are used to establish demands on joints, which account for uncertainties in load intensities as well as the likelihood of different types of loads occurring concurrently at their largest value. The actual loads carried by a joint may be less than those predicted by load combinations. It is not uncommon for joints to be designed for arbitrarily determined forces (half of uniformly distributed load—UDL—for example) rather than being designed for the shear forces that would result from the actual loads carried.

Furthermore, connections are often designed so that the controlling limit state is not the bolt shear capacity, but rather some other, more ductile limit state. Often, the bearing strength or block shear strength of the connected material controls the design of the connection, particularly when thinner plies are joined, which fortunately is also when bolts manufactured as “fully threaded” are most likely to be used. In other cases, the strength of the connected members themselves may govern the design of the component. Additionally, bolts are designed with a higher reliability factor than members. Finally, the slip resistance of bolted joints is not affected by this issue. This altogether implies that other failure modes may prevail before our X-turned-N bolt reaches capacity. Several of the possible limit states might be controlled by less penalizing resistance factors.

### But are my designs safe?

We do not know of any structural failure that can be attributed to this issue. A more formal study was performed, running thousands of Monte Carlo simulations on several joint configurations to investigate the probability of failure. Also investigated was the associated reliability factor of joints that employ bolts with a suspect body length, or a body length known to be shorter than originally assumed in design. (Monte Carlo simulations are a compilation of several cases using randomized values of the variables that control the strength of a joint to provide a meaningful statistical sample of the strength outcomes.)

This study is described in the second referenced *Engineering Journal* paper. It was concluded that the reliability of joints with bolts that have been designed as X but may ultimately be in the N condition depends on several factors, including the grade and size of bolts, the length of the joint, and which edition of the AISC *Specification* the designer used. For many joints, the target reliability is still

met despite the reduced bolt capacity, and many other joints still meet the reliability that is desired of members, if not that of joints, implying a probability of failure of the joint that is similar to the probability of failure of a member—a routinely accepted risk.

The shear strength equations were changed in the 2010 *Specification*, in part because of the bolt overstrength issue mentioned earlier, resulting in a calculated strength per bolt that is 20% higher than previous editions of the *Specification*. The results of the Monte Carlo simulations show that joints designed based on versions of the *Specification* predating the 2010 edition are considerably more forgiving, especially for compact joints ( $L \leq 16$  in.), slightly less so for long joints ( $L \geq 50$  in.), and definitely less so for intermediate length joints ( $16 \text{ in.} < L < 50 \text{ in.}$ ). Table 2 summarizes these results.

Table 2. Reliability indices for bolted shear joints designed as X but installed as N ( $L/D = 3.0$ ).

Grade	AISC Specification Prior to 2010			AISC Specification 2010 and 2016		
	120	120	150	120	120	150
Diameter, in.	$\frac{5}{8}-1$	$1\frac{1}{8}-1\frac{1}{4}$	$\frac{3}{4}-1\frac{1}{8}$	$\frac{5}{8}-1$	$1\frac{1}{8}-1\frac{1}{4}$	$\frac{3}{4}-1\frac{1}{8}$
Compact	3.94	3.59	3.24	3.36	2.99	2.65
Intermediate	2.61	2.29	2.01	2.28	1.94	1.64
Long	3.07	2.79	2.54	2.48	2.19	1.95

Considering that a reliability index of 2.5 (which is the target reliability for members in the *Specification*) corresponds to a probability of failure of 0.621%, Table 2 provides guidance to designers for assessing the risk incurred for a joint that may have bolts in the N condition when designed for X.

### Designing for the Future

To ensure that future joints are designed conservatively, it is recommended that:

- The design of shear connections considers the minimum available body length published in ASME B18.2.6, instead of using reference thread lengths provided in tables.
- The transition area between the threads and body should be considered in the N condition.

Engineers should carefully weigh the considerations presented here and in the referenced *Engineering Journal* papers before considering replacement or redesign of bolts in the joints of existing structures. In short, don't panic. Keep calm—and bolt on. ■

#### • A Longer Take on Short Shanks

The first quarter 2020 issue of AISC's *Engineering Journal* included two papers written by Swanson, Rassati, and Larson that present a longer discussion of the topic covered in this article. “Dimensional Tolerance and Length Determination of High-Strength Bolts” and “A Reliability Study of Joints with Bolts Designed with Threads Excluded but Installed with Threads Not Excluded” discuss concerns with designs that assume bolts are installed with the shear plane excluded from the threads, but in practice result in the shear plane crossing the threads, especially for cases involving short bolts. AISC members can read both articles—and access the entire archive of *Engineering Journal* articles—at [aisc.org/ej](http://aisc.org/ej).



# field notes

## MAKE IT HERE

INTERVIEW BY  
GEOFF WEISENBERGER

Zekelman Industries CEO Barry Zekelman doesn't just want you to use American-made steel. He wants you to use American-made *everything*.



Field Notes is *Modern Steel Construction's* podcast series, where we interview people from all

corners of the structural steel industry with interesting stories to tell. Listen in at [modernsteel.com/podcasts](http://modernsteel.com/podcasts).



**Geoff Weisenberger** ([weisenberger@aisc.org](mailto:weisenberger@aisc.org)) is senior editor of *Modern Steel Construction*.

**WHEN BARRY ZEKELMAN** and his brothers took over Atlas Tube (an AISC member HSS producer), the tiny company was on the verge of bankruptcy. Today, Zekelman Industries (the parent company of Atlas) is a \$2.7 billion company—with Barry at the helm as executive chairman and CEO—and is the largest HSS and tube producer in North America. And through a new advertising campaign, he is working to push for industries of all types to grow and maintain their manufacturing operations here in the U.S.

Zekelman Industries' "Make It Here" ad campaign has appeared in prominent publications like the *Wall Street Journal*, *Fortune*, *Inc.*, *USA Today*, *Forbes*, *Entrepreneur*, and *Fast Company*. Can you tell me a little bit about what prompted it? What's it all about, and who is it designed to reach?

I think what really prompted it was my own feeling and my own experiences with making things in America and what it's done for the communities where we have our businesses and operations. I get a little bit tired of hearing people say that you can't make things competitively in North America or that industry here is dying. I just don't believe that. We're living proof that it isn't true. We're regarded as the most efficient tube producer in the world, we consume two-and-a-half-million tons of steel a year, we're the largest structural tube producer in North America, and we're expanding. We're in the process of installing the largest ERW [electric resistance welded] tube mill in the world for the largest hollow structural sections [HSS] that will be available in ERW form.

I believe that a rising tide floats all boats, and I think that a lot of the problems we have today—the angst, tension, anxiety, drugs, unemployment, crime—are rooted in the fact that many communities have lost a sense of purpose thanks to so many jobs being vacated, and the cost of that is far greater than people can ever imagine. We always try to get goods as cheaply as we can, but the back-end price is crumbling communities and unrest. We need to get back to the old "making it here" mentality and support our communities.

**It's a very holistic and unifying message. Have you seen a good response to the campaign?**

We've seen a tremendous response. I'm getting calls and emails from all different segments of industry and business, and not necessarily about our company specifically. That's not what this is about. I'm not looking for someone to come to me to buy some tube because of those ads. People are coming to me asking me for advice on how they can get something, not just steel, made here in America, and I try to use my resources to hook them up with the right people. We want to create a network of people that can talk to each other and share their ideas and maybe help each other build businesses here. I believe people want to do the right thing. There will always be those who take a very easy path and go to China or Thailand to quickly find what they're looking for. It might take a little more effort and money to get what they need in the U.S., but the benefits of doing so are fantastic.

**What do you say to a building owner who tells you they're putting up a new high-rise and they'd like to use American steel, but they can get the steel, say, 5% cheaper from overseas?**

First off, I'd ask, "Are you sure about that?" There are lots of different ways to value engineer things via different technologies. Number two, think about the cost of the steel going into that building. It's a fraction of the total cost, and 5% is a fraction of that. Also, think about where your money is going. With our new ERW mill, the machinery itself is about \$70 million. I was told we could save \$10 million by getting the castings and main housings in China, and I said, "Absolutely not. No way." It's a lot of money, but consider that it's an asset that might last 50 years.

There's another piece of equipment we're getting, and I demanded that the steel be fabricated in American shops. I wanted to build as much of it in America as we can, and it cost us a couple hundred thousand dollars more. But we're using American Steel, producing American tube made by American workers who are going to pay American taxes. You have to look at the whole circle of life. You don't always have to squeeze every bit of juice out of the lemon. When you pluck everything off the tree, there's nothing left. You need to leave some fruit hanging there and let the tree flourish. We need to rethink the whole value proposition of what we're doing here and what it really means in terms of jobs.

**It's widely known or at least perceived that there's a shortage of younger people looking into manufacturing for their careers. Do you have any thoughts on the best ways to get the next generation to consider jobs in welding, ironworking, fabrication, mills, or just manufacturing in general?**

We've done a terrible disservice, basically telling kids from a very young age that getting dirt under your fingernails is a bad thing. I don't think there's anything wrong with going to a college or university, but there's also nothing wrong with working with your hands. But we've sent too many kids down the college path that maybe weren't meant for it, we've given them this grand illusion, and now we're paying for it. We've got lots of people out there who don't know how to work with their hands, who look down upon it, and we're losing that skill set. So we have to help young people identify the best pathway for them and let them

know they can excel in the trades. I mean, I know welders who are making more money than lawyers. We need to publish the incomes of some of the people who have gone into the trades and have them communicate how much they enjoy their jobs. It's gratifying to make something or point to something that you made.

We need to promote that happiness and show that our industry is thriving, and we also need to show the investment we put into it. Our industry and many others have high-paying, high-gratification jobs with a lot of room to learn and expand and grow, and I think young people need to see that. We need to go to schools and show kids cool machinery and cranes and robotic welding and plate benders and lasers that cut sheet and tube, and show them how cool it is because it is cool. It's a very cool industry and there's a lot of sophistication, and it can be a lot of fun.

**What makes you optimistic about the construction industry moving forward? And thanks to COVID, do you see major shifts in terms of what types of buildings are going to be built?**

So the trend of everything moving to suburbia will only last for so long. People need to be together. You can't just keep doing everything on a Zoom call. Sure, we're seeing a massive increase in warehouses, distribution, data centers, and power generation to power the data centers. And if suburbia is going to keep exploding, you're going to have to have buildings around to support it. It'll be a different type of construction, and buildings are going to have to be bigger for the occupancy. I do think it's an overreaction, but we'll have to figure it out.

Right now, a lot of businesses are getting pummeled. We still haven't seen the full effect of these small businesses that are going to get crushed. That's the problem. The little guy is getting crushed.

**You and your brothers took over the company's leadership in 1986 upon your father's passing. Did you ever have another career path in mind when you were younger, or do you feel that you were destined to join the family business?**

My father's business was more than just tube. In 1986, the tube operation had five employees and was within months of bankruptcy. I was always mechanically inclined, and I knew how tube was made because I'd walked through the plant. But other than that, I didn't know a damn thing. I actually wanted to be a fighter pilot. We were naive and we sat down and looked at the business and basically said, "Let's just give it a shot and see how it goes." And that was it. I learned how to run a mill, I learned how to do the paperwork, I learned how to run a crane and load the truck, I learned how to run a slitter. We did whatever it took, and now here we are. Most of all, I learned how to surround myself with great people who know what they're doing, and I empowered them to go do it, and that's the beauty of this company. It's not our shiny equipment, it's the team we have and what they do, and how they do it, and how they execute, and how they watch each other's backs, and how they take care of our customers, and how they take care of our suppliers—and we have a lot of fun. ■

*If you'd like to hear more from Barry, including his thoughts on Buy American provisions, advice from his father, and his passion for racing, visit [modernsteel.com/podcasts](https://modernsteel.com/podcasts).*



# business issues CONNECT AND COLLECT

BY ANNE SCARLETT



**Anne Scarlett** is president of Scarlett Consulting, a Chicago-based company specializing in AEC-specific strategic marketing plans, marketing audits, and coaching. She is also on the adjunct faculty at Columbia College of Chicago and DePaul University. She can be contacted via her website, [www.annescarlett.com](http://www.annescarlett.com).

Your clients are eager to talk.  
Now is the time to set up a client perception survey to connect with them and collect their thoughts.

**AS WE ENTER MONTH TEN** of the pandemic, everyone remains stretched thin, both personally and professionally.

In some ways, we are busier than ever. In other ways, we've recaptured valuable time thanks to less commuting, less business travel, and fewer "standard" entertainment options. Many of us are still working to some degree in isolation, despite the countless video meetings, which can result in Zoom fatigue.

With this in mind, when I was recently contacted by a couple of firms to conduct surveys on their behalf, I was cautious about managing expectations in terms of participant enthusiasm, openness, and reachability. Luckily, I was pleasantly surprised on all counts. Participants were ready to connect, be heard, to contribute.

While there are several methodologies for conducting client perception surveys, my personal favorite for AEC professional service firms is a journalistic interviewing method, using the tried-and-true telephone. One-on-one phone interviews result in detailed, emotion-rich responses that can be used in myriad ways for your business.

## Why Surveys?

Simply put, a client perception survey checks all the right boxes: time well spent, effort well spent, and money, you guessed it, well spent. Here is just a short list of expected useful outcomes from conducting a survey. Doing so can:

- **Provide two to three touchpoints to existing clients or hot prospects.** Specifically, in the form of an initial introduction, phone interview, and follow-up.
- **Help you identify your clients' industry challenges and trends.** To encourage responses beyond the pandemic, inviting pre-pandemic responses is also an option.
- **Demonstrate your level of commitment toward client happiness.** Nothing says, "We care," like listening.
- **Float ideas.** This provides your firm with the opportunity to try out new ideas for client input.
- **Test your assumptions.** Sometimes, you get a piece of humble pie as the result of these surveys, further reinforcing the importance of collecting this information.
- **Provide an opportunity to summarize and share relevant results.** It's a fair and reasonable trade to provide all participants with a few findings from your survey if they're interested. This can be done in a casual blog or a more formalized article or white paper.
- **Help round out your existing marketing plan.** The strongest business development and marketing plans carefully consider data from external sources. Without this input, action items might be off-the-mark and opportunities might be overlooked.

## Why Now?

While the full impact and eventual aftermath of the pandemic remain fuzzy, there is no time like the present to collect information. For example, when you are scenario planning for 2021 and beyond, your survey data can help inform your alternatives. Even better, when we finally have more clarity about the world at large, you'll already be ahead of the game, ready to slice and dice the data and put it to good use.

Conducting a survey right now saves you that extra step later, when you will mobilize and make proactive business decisions. Even if you need to revisit and clarify survey findings after the COVID dust settles, it will still be faster than starting a survey from scratch.

Conducting a survey now also allows you to connect with those who may have been hit directly by the pandemic. Simply put, you will have a chance to offer genuine and timely empathy to your clients.

## What to Include?

So what are some best practices for client perception surveys? And how can you best craft, execute, and interpret the data?

Essentially, you'll be looking for themes among the responses. That said, you may uncover isolated but worthy nuggets, such as "real" language or a mini-anecdote that can be woven into your marketing messages.

Here's some advice when it comes to designing the survey and formulating questions:

- **Develop an open-ended line of questioning.** It's no surprise that questions need to have enough wiggle room for the respondent to elaborate.
- **Limit the prepared questions to four or five at the most, and consider the sequence.** Strategically sequence the questions to hook clients' interest right away while also letting them warm up by beginning with the big picture and moving toward more specific topics.
- **Carefully craft questions to glean the most depth from responses.** If you seek feedback on, say, specific aspects of your business offerings from a prior project, then those can just as easily be answered in a scaled-online survey. For each question that you are considering, challenge its value to make sure that it is worthy in this context.
- **Recognize that your sample size will be small.** I usually aim to survey 15–20 clients to represent each market sector or practice group. Quality greatly outweighs quantity, and you can always expand your reach through a separate, scaled-online survey.

In advance of the survey, you should:

- **Announce the survey.** (Obvious, right?) Send an email to targeted recipients, introducing the survey and requesting participation. Make sure they understand the type of information you are collecting, whether it be overarching industry insights, perception of your brand, or favored service providers. In a succinct message, let them know the general gist of the survey, along with how you hope to use the information.
- **Offer to give more details about the questions.** If a participant expresses interest and would like to know more first, don't hesitate to share the short set of questions. Sometimes people like to think things through first before sharing their perspectives.

When you're ready to perform your interviews, consider the following:

- **An unbiased third party can tease out additional candid responses.** If at all possible, the interviewer should either

be a trained consultant or a trusted internal colleague that doesn't know the participant directly. In fact, due to reductions in billable work, this is a perfect use of time for a savvy, communicative professional. (Pro tip: If you plan the interviews to be conducted by an internal colleague, then be sure to practice the interviews with them first through role-playing. It will be worth the effort, and it will definitely serve to strengthen the participants' experience.)

- **Voicemails are OK!** Leave voicemails that are reasonably succinct but give enough information to express your genuine gratitude for your clients' participation.
- **Respect your clients' time and read their tone:** During the call, you'll be able to tell if they are rushed, chatty, or somewhere in between. Regardless, kick things off by confirming that it's a good time for a 15-minute conversation, and let them know you will be setting your phone alarm. They may request to finish in 10. They may reach 15 minutes and agree to speak awhile longer because they are enjoying the conversation. Be flexible.
- **Let it flow.** The top priority is to get the client sharing in their own words. Try to probe without influencing their response. Make it feel like a conversation rather than an interrogation. It should be enjoyable for the interviewee, and they should feel like they are truly contributing to an important result: the actionable client perception report.
- **Create communication options.** Twice during my recent surveys, a few participants from the same company requested to participate as a small group. We did this on Zoom, and it gave them the opportunity to build off one another's responses while also remaining independent and willing to respectfully disagree.
- **Capture the "calling notes" but know it won't be perfect.** Unless you request permission to record the calls, you will be frantically typing as the respondent talks. It's OK if it's messy. Do your best to document the important bits, and know that you are not expected to be a professional transcriber.
- **Offer anonymity:** One of the best benefits from this type of interview-based survey is the language: quotes (for white papers and blog posts), testimonials (to vouch for your company), and "real talk" (for marketing materials and advertising). However, if the respondent prefers to remain anonymous, then this must be established in advance. Even so, their input will still be useful in your overall findings.
- **During tough times (e.g., pandemics), be sure to empathize.** While we can't possibly know what each individual is experiencing during this time, we can undoubtedly relate to the fact that we have all been incredibly challenged. Uncertainty continues while we remain hopeful that solid answers are imminent. Even the smallest sliver of human-to-human connection can help build rapport between the interviewer and the participant, between you and your client.

Very few things are certain these days, but it's safe to say that people still appreciate feeling heard, and they still want to help and contribute. A client perception survey provides an opportunity for both. ■





Every year, *Modern Steel* presents a compendium of fun projects showcasing the cool use of steel. While this section has traditionally run in August, along with our Hot Products section, this year we figured we'd leave the heat in that issue and bring the cool to December.





# What's Cool in Steel

.....

The 2020 list includes a Mississippi facility geared toward maximum entertainment, an Oregon pedestrian bridge that blends in with nature, a striking stage in Iowa's capital city, a Philadelphia high-rise with an attention-commanding truss, and several other attractive steel wonders. And in addition to these recently constructed projects, we're featuring a blast (zone) from the past that demonstrates the staying power of steel.

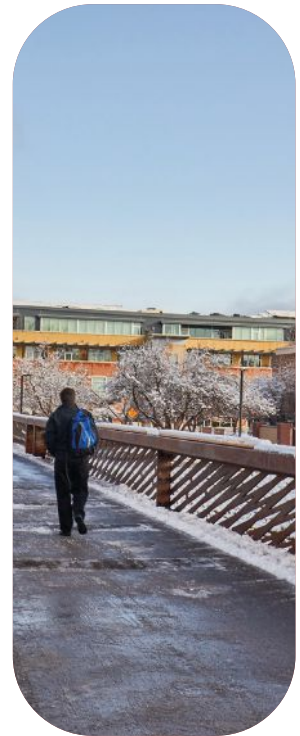
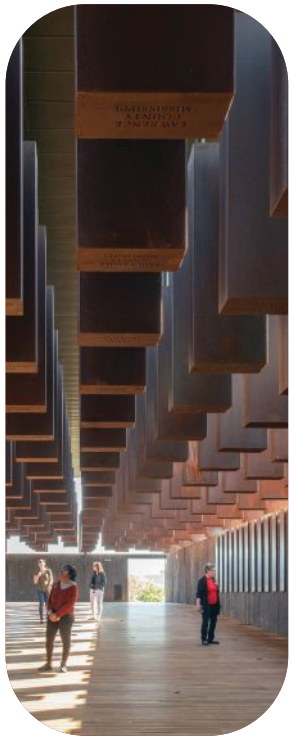



## Cool Tri-Chord Truss

Portland's Wildwood Trail winds 30 miles through contiguous forested parks along the western edge of the city, rarely crossing roads. For many years, the busiest road crossing was at West Burnside, a major city arterial, where runners and walkers were forced to negotiate three lanes of heavy traffic with short sight lines.

At the request of a local citizens group, artist Ed Carpenter developed a bridge that would blend seamlessly with the experience of the trail. Carpenter was himself a 40-year trail runner and "survivor" of the crossing at West Burnside. And he had already designed a number of unusually expressive bridges in addition to monumental sculpture commissions around the world.

Carpenter spent two years in a mostly solo effort studying different schemes, collaborating with KPFF Consulting Engineers, and meeting with more than 20 neighborhood groups, nonprofits, city commissioners and bureaus, and then-Mayor Charlie Hales, promoting the project before convincing Portland Parks Foundation to take on the role of prime sponsor.

Now known as the Barbara Walker Crossing, the bridge eventually became a project of the Portland Parks Foundation in partnership with Portland Parks and Recreation (PP&R), Portland Bureau of Transportation (PBOT), and Metro. The curved steel bridge, whose basic structure is a tri-chord truss of weathering and painted steel, is 178 ft long.

KPFF provided structural engineering, civil engineering, surveying, and project management for the bridge. The three-dimensional steel truss is an efficient structure type for a bridge on a curved geometry. The open nature of the truss, along with the flexibility in the placement of the structure's vertical and diagonal members, enabled Carpenter's aesthetic vision for the bridge to be realized.

The design evokes the sword ferns and vine maples lining the entire length of the Wildwood Trail. In addition, it strives to honor the design objectives of providing a seamless experience for walkers/runners, fitting into the surrounding forest context with minimal intrusion, appearing transparent and delicate yet iconic, and being built via off-site fabrication, quick to erect and easy to maintain.

The bridge is constructed of four different round hollow structural section (HSS)

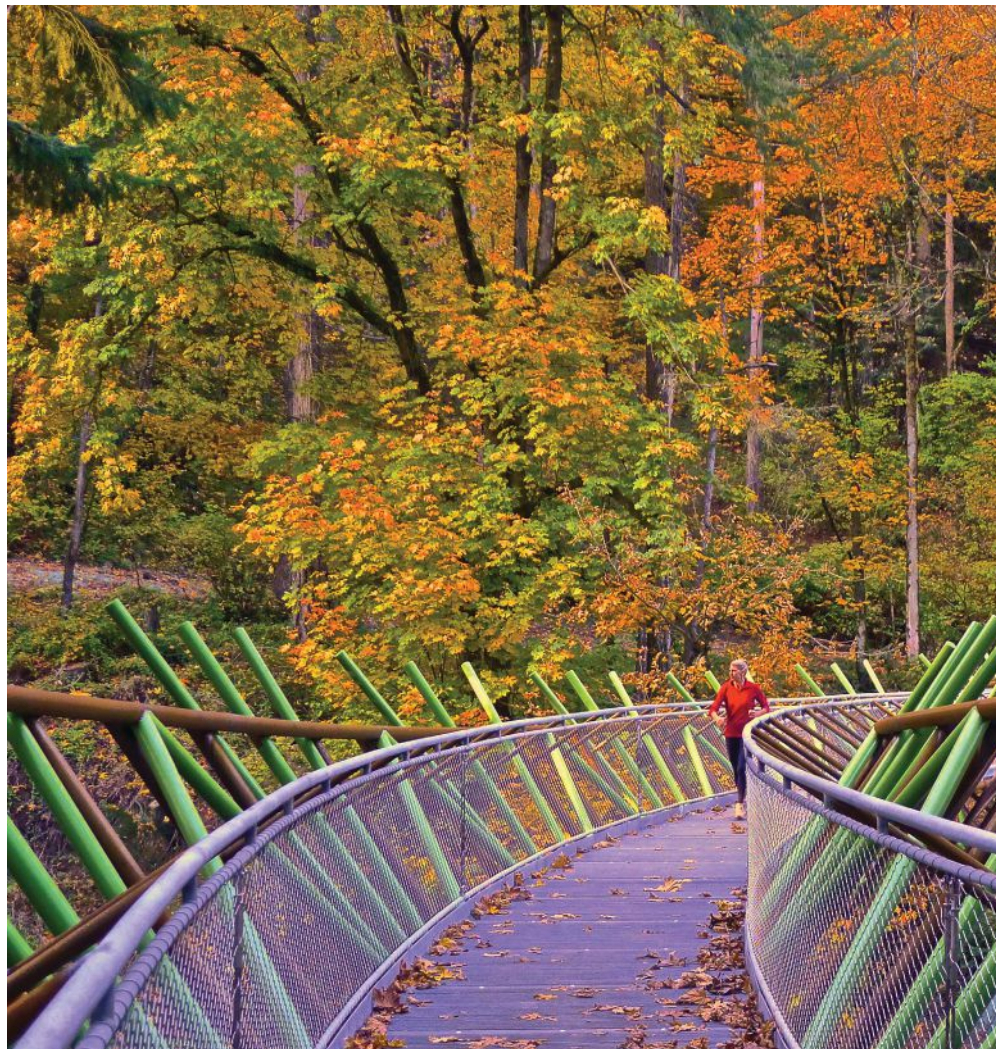



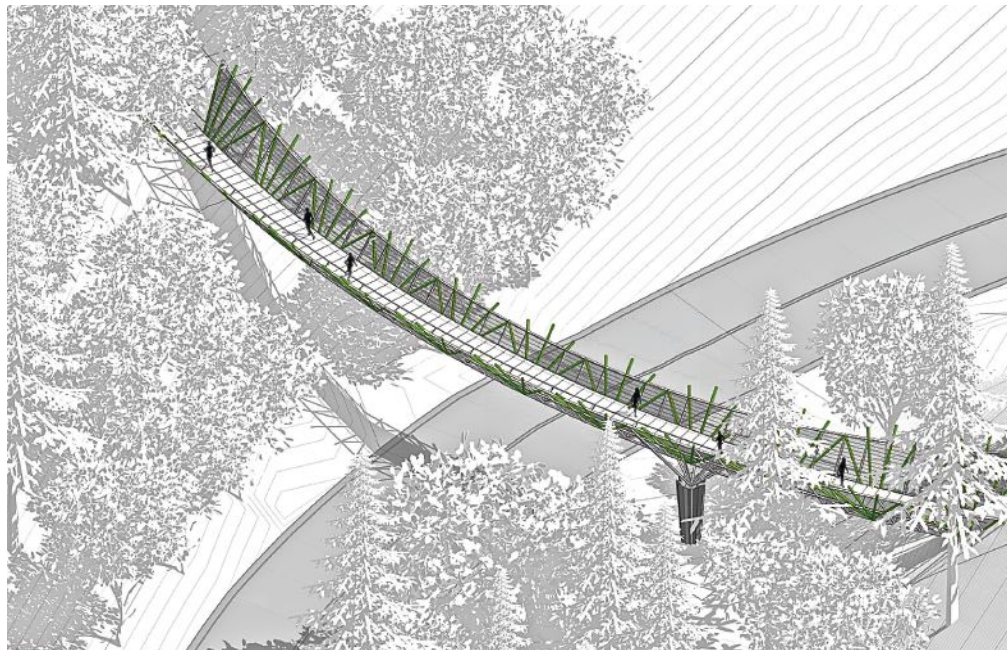



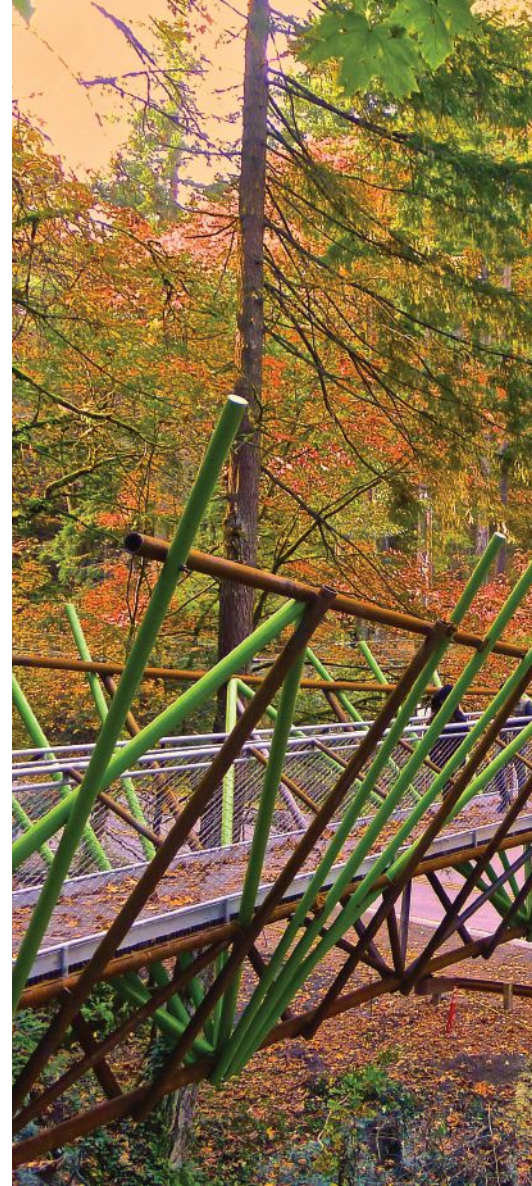
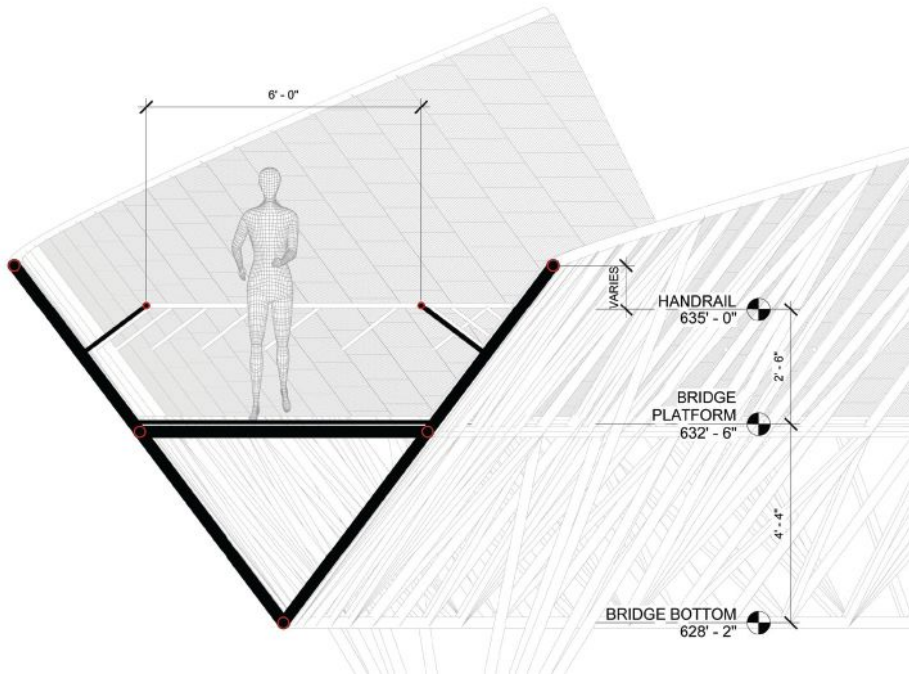





types: 3-in., 3½-in., 5-in., and 1½-in. (the latter for the handrails). The steel totals 19 tons, all of it weathering steel except for the galvanized steel handrail. A multi-coat, high-performance Tnemec Paint system (light green) was used for some of the weathering steel members while others were left unpainted, allowing the steel to mimic leaves, branches, and trunks. Supreme Steel fabricated the steel for the bridge, with Albina Company, Inc. (both AISC members) providing bending-rolling services for the curved portions.

Transportation of a nearly 180-ft-long, curved bridge presented challenges. Approaching the bridge site from the east would require transportation through downtown Portland, while the approach from the west included a narrow tunnel. The latter approach was selected, and the bridge was broken up into three curved sections that could each fit through the tunnel.

The erection process involved installing the south section and shortest span first, followed by the two remaining sections that formed the longer span. The longer span was spliced on the ground to avoid any temporary shoring in the roadway, and erection was completed during a single three-day closure of the roadway.





Greg Slay



Max Marketing

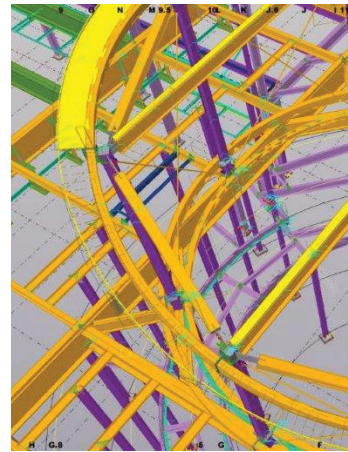

Max Marketing







## Cool Entertainment Experience

The Mississippi Arts and Entertainment Experience, informally called the MAX, is the result of twenty years of effort on the part of local and state government officials, local celebrities, and community leaders. Through their persistence and determination, the MAX has materialized into a state-of-the-art venue for the arts, entertainment, and education in downtown Meridian, Miss.

The MAX is a 60,000-sq.-ft structure containing a 22,000-sq.-ft exhibit space, with the other 38,000 sq. ft housing a broadcast studio, an outdoor performance area and courtyard, a multipurpose area, and an art studio. The MAX displays the work of Mississippian actors, actresses, authors, musicians, performers, and industry leaders in entertainment. Steel (550 tons) was chosen as the primary framing system for its strength and openness compared to other structural materials (the MAX, like most museums and exhibit spaces, required large, clear-span spaces).

LPK Architects led the design team and was assisted by Gallagher and Associates, an internationally recognized museum planning and design firm, along with Canizaro Cawthorne Davis. Walter P Moore and Associates (WPM) was the structural engineering firm of record for the project, and Slay Steel was the steel fabricator, with Bracken Construction Company, Inc., acting as the erector; both Slay and Bracken are AISC members.

The team desired an open cylindrical volume (the Hall of Fame) that required some creative structural engineering. While a unique element to the building, the solution was relatively straightforward. WPM used a continuous HSS12×6× $\frac{3}{8}$  with a curve radius of 22 ft (curved by AISC member bender-roller Whitefab) to provide a circular ring around the rotunda and provide support for the 3-in. steel roof deck. The lateral stability of the rotunda was provided by four bays of rod bracing with conventional clevises and turnbuckles.

Additionally, the design called for structural glass fin walls along the north and east elevations to showcase both the Hall of Fame and the exterior courtyard spaces, allowing patrons inside the building to engage with entertainment taking place outside.

The site chosen for this project is directly adjacent to a major railroad track and train switching yard, which raised concerns

related to vibration and noise levels. WPM performed a vibration study that included field monitoring ambient ground-borne vibrations for 24 hours to capture typical freight train, commuter train, and vehicular traffic effects. This study was performed to confirm whether any modifications to the steel structure would be required to mitigate any potential vibration concerns. Ultimately, the measured ground-borne vibrations were determined to be within acceptable limits for human perception.

The complexity of the engineering was combined with the creative requirements of the architectural and exhibit teams regarding the use of 3D building information technology (BIM) and Autodesk Revit models during the design phase. The roof framing consisted of standard steel roof deck over wide-flange beams supported by heavy wide-flange girders and incorporates multiple long cantilevered sections. Deflection compatibility during the various stages needed to be considered and optimized in design and then reviewed and adjusted with Bracken to ensure pieces fit-up during the various stages of erection. The cantilevers range in length from 32 ft to a maximum of 47 ft at the northeast corner, each with different loading, resulting in numerous loading conditions to be verified. WPM provided very specific end-of-cantilever tip cambers for each beam with the intent that after the dead load deflection had occurred, the cantilever tips would be at the specified elevation. Once it was all detailed in accordance with the specific cambers, the members fit up well in the field.

Prior to erection, deflection compatibility was again of utmost concern, but with the focus redirected to movement during the building's service life rather than construction. Installation of the structural glass fin walls required 36 ft of structural glass with 24-in.-deep glass fins at 5 ft on center to be suspended from the same cantilevered roof girders with stringent deflection criteria. High winds loads on the structural glass in conjunction with unbalanced roof live loads on long cantilevered members required upsizing of several roof beams and girders to minimize potential movement.

Since the MAX has opened, it has been a hub for artists and entertainers from the area. Not only that, but it can also be credited with bringing a new architectural icon and renewed interest to downtown Meridian.





### Cool Homage to Roller Coasters

Des Moines' Riverview Park is breathing new life into an old public space.

The area was previously home to an amusement park that operated from 1915 to 1978. The park was sold, closed, and dismantled, sitting empty for decades until its recent redevelopment, which includes the new steel-framed Riviera Stage. The park is bordered by the Des Moines River to the south and west, held back by a levee, and a lagoon to the north and east. The new park, which is connected to the city's trail system, was conceptualized by the Parks Area Foundation of Des Moines and designed by Architects Schipper Kastner (ASK) Studio, with Raker Rhodes Engineering providing structural design services.

The Riviera Stage, the new park's focal point, is an elevated performance stage (50 ft wide by 32 ft deep) with a large open green space for concertgoers. The stage is situated below two structures designed with the park's past in mind. The open-air canopy is reminiscent of the former amusement park's Riviera Ballroom, and the arch structures invoke visions of roller coasters. The stage is

covered by a steel canopy, constructed of round HSS sections. The canopy consists of two main arches (HSS14×0.625) with a radius of 46 ft and rising nearly 40 ft above the ground. The main roof structure (shapes ranging from HSS5.5 to HSS12.75) is suspended from the arches by HSS hangers and tied to two 12-ft-long by 4-ft-wide by 18-ft-tall concrete piers. The roof is topped by ¼-in. steel plate with plate stiffeners spaced at 4 ft on center. All connections are fully welded. Flying over the canopy is a superstructure comprised of two arch box trusses spanning 120 ft and rising 60 ft into the air, supporting a 95-ft-long box sign truss. The arch trusses are a premanufactured product, supplied by ClearSpan (a fabric structure manufacturer) and stitched together with round HSS horizontal web members. The sign truss and canopy structure were fabricated by AISC member Johnson Machine Works, with AISC member Chicago Metal Rolled Products providing bending-rolling services for the curved steel elements. The stage and concrete piers are supported by reinforced concrete spread footings, and due to relatively soft and compressible soils on the site, foundations are supported by vibratory stone columns.

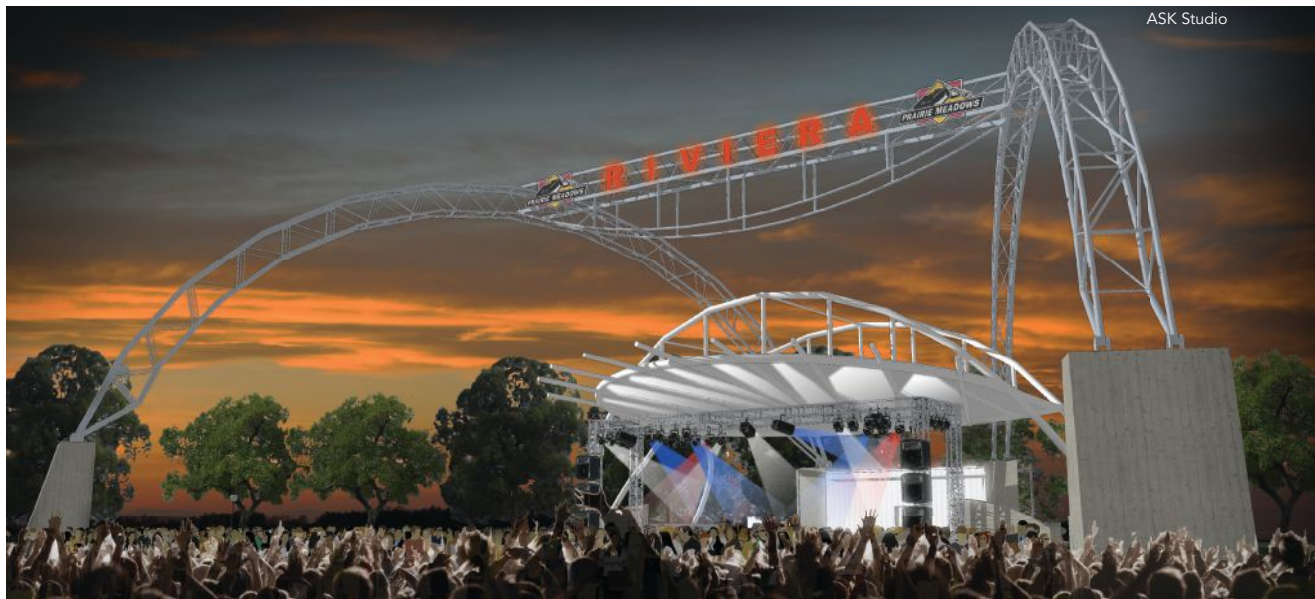
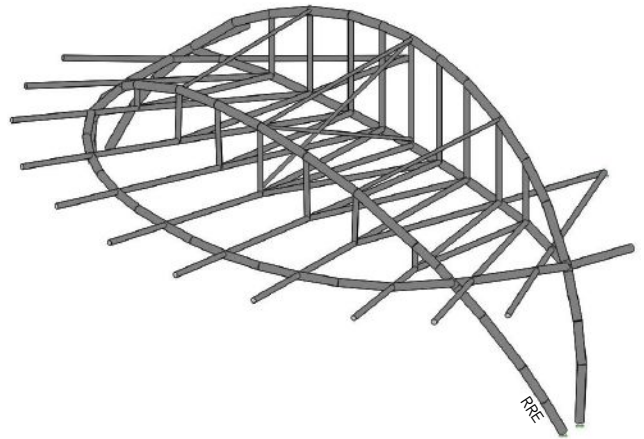

The project also includes various secondary structures, including a donor's plaza, an entry monument sign over an existing pedestrian bridge, and two age-oriented, accessible playgrounds. Extensive site work was also performed, including raising the grade to help protect against flooding and new sidewalks connecting directly to the local trail system.

Due to budgetary constraints, the project was broken into three construction phases: 1) stage, foundations, and related utilities; 2) site work and; 3) Canopy, arch structure, and other miscellaneous secondary structures. Each phase was bid separately and awarded to three separate contractors. The phased construction was particularly challenging for the fabrication and construction of the canopy and arch structures because the foundations (including anchor rods and embed plates) were built by a separate contractor under a previous phase. This required careful field verification of as-built conditions prior to fabrication of the canopy structure. Another fabrication challenge was constructing connections between intersecting round HSS tubes at various angles. Careful fabrication of copes was required, and connections were fully

welded (up to ½-in. fillet welds and complete joint penetration welds were required). In order to ensure proper fit-up, Johnson assembled the canopy at its shop. The canopy was then split into the largest practical shipping sections, shipped to the site, and then spliced back together on-site via full-penetration welds. Once the canopy was erected, the decking was laid and fastened to the structure using powder-actuated fasteners.

Erection of the arch structure followed the stage canopy. The four premanufactured arch trusses consisted of five segments, which were bolted together on the ground. The arches were then lifted into place and secured to the concrete piers. Once in place, the arches were stitched together with field fabricated webs. Due to the varying width of the arch boxes, the length and angle of each web varied from piece to piece. Finally, the sign truss was lifted into place and connected to the arches. After completing steel erection, lighting and sign work were installed on the structures.

While no longer an amusement park, the new iteration of the green space provides its own form of entertainment and revitalizes the area as one of the city's most scenic outdoor gathering spaces.



## Cool Tower and Truss

The Harper stands out—especially its 110-ft-long ground-level exposed truss that projects from the lobby to the exterior.

Located at the site of the former Boyd Theater, the 25-story, 260,000-sq.-ft mixed-use building in Philadelphia features 183 apartments and two floors of retail space, as well as office space, an outdoor pool, and an underground garage. Designed by DAS Architects Inc., the building reaches 314 ft above grade and is the tallest all-steel structure in the city with no concrete core.

The Harper features several creative solutions to structural desires posed by the owner and the architect. Of paramount importance to the retail plan was the elimination of every other column on the standard 24-ft by 26-ft column grid that was used in the parking area and the apartment tower. As a result, outside of the tower footprint, engineer the Harman Group used long-span steel girders that enable large column-free spaces in the retail area. Below the apartment tower, nine columns were transferred out using five stick-framed trusses (not including the lobby truss) and two built-up plate girders.

The owner was keen to reduce costs incurred by transferring out columns to create more retail space. The Harman Group responded by using A572 – Grade 65 steel for all columns and truss members 90 lb per ft and heavier. As a result, the design saved approximately 200 tons of material, and the owner saved approximately \$180,000, an amount significantly higher than Harman’s design fee. And according to Arcelor-Mittal, the Harper is the first residential tower and only the second building in Philadelphia to use 65-ksi steel.

The construction site was challenging thanks to the limited material lay-down area and crane capacity. This lack of space and crane capacity, typical for an urban environment, meant that the transfer trusses could not be built on the ground and lifted in one piece to the transfer level. Zero camber can be difficult to achieve when stick-building trusses. The top or bottom chord of the truss is erected first and will deflect significantly under its own weight. If not corrected, the transfer columns will start off too low, causing the entire building to be too low at those column locations.

The trusses were stick-built and the deflection in the top chords, just from self-weight, was between  $\frac{5}{8}$  in. and  $1\frac{1}{4}$  in. To correct for this deflection, the trusses were erected and all of the bolt holes were stuffed but not tightened. Then, steel erector Independence Steel/XLE (an AISC member) jacked up the trusses to set zero camber, and shoring and spreader beams were added to distribute the load from the jacking operations. Next, the tower crane was used to pull up on the truss until the crane hit its load limit, then jack pressure was applied. As the jacks took the load off the crane, the crane applied more force until the trusses were level.

After the surveyor verified that the truss was at the proper elevation, all of the bolts were tightened to meet the project’s specifications. When the bolts were tightened, the jacks and crane were released and the surveyor did a final elevation check. After tightening all the bolts, deflection due to self-weight of the truss was minimal:  $\frac{1}{16}$  in. or less (almost exactly zero camber).

Back to the lobby truss, it is actually the balcony truss from the Boyd Theater. When the theater was demolished, the truss was carefully cut into five sections that would be light enough to be removed by the crane. Thanks to custom supports, the repurposed, non-loadbearing truss, weighing approximately 75 tons, now “floats” above the lobby floor.





# “Elevating” Train Stations with Elliptically Curved Pipe

Cermak-McCormick Place  
Elevated Train Station, Chicago IL

Chicago Metal Rolled Products curved 68 pieces of round 8” HSS .375” wall A500 grade B pipe to an ellipse curvature featuring multi-radius bends for the structural ribs that hold up stainless steel panels and polycarbonate skylights of the Cermak-McCormick Place “L” Station in Chicago, IL. The tube structure was designed so the covered platform was both light-filled and weather-protected while still providing direct views of the city.



**Call us at 866-940-5739**

For savings on quality roll-curving  
of structural steel, sheet and plate  
delivered to meet your schedule.



**CHICAGO METAL  
ROLLED PRODUCTS COMPANY**

CHICAGO • KANSAS CITY  
[cmrp.com](http://cmrp.com)







**1 Angle Leg Out** We bend ALL sizes up to:  
 10" x 10" x 1" Angle

**2 Angle Leg In**  
 10" x 10" x 1" Angle

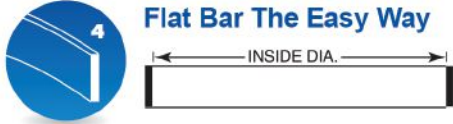
**3 Flat Bar The Hard Way**  
 24" x 12" Flat

**4 Flat Bar The Easy Way**  
 36" x 12" Flat

**5 Square Bar**  
 18" Square

**6 Beam The Easy Way (Y-Y Axis)**  
 44" x 335#,  
36" x 925#

**7 Beam The Hard Way (X-X Axis)**  
 44" x 285#

**8 Channel Flanges In**  
 All Sizes

**9 Channel Flanges Out**  
 All Sizes

**10 Channel The Hard Way (X-X Axis)**  
 All Sizes

**11 Tee Stem In**  
 22" x 142<sup>1</sup>/<sub>2</sub># Tee

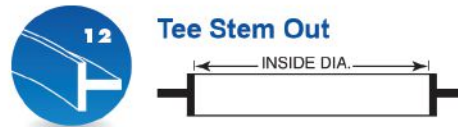
**12 Tee Stem Out** We bend ALL sizes up to:  
 22" x 142<sup>1</sup>/<sub>2</sub># Tee

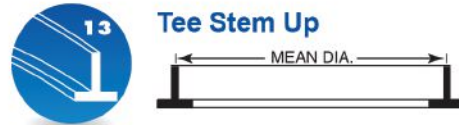
**13 Tee Stem Up**  
 22" x 142<sup>1</sup>/<sub>2</sub># Tee

**14 Angle Heel In**  
 8" x 8" x 1" Angle

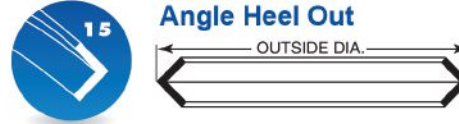
**15 Angle Heel Out**  
 8" x 8" x 1" Angle

**16 Angle Heel Up**  
 8" x 8"x1" Angle

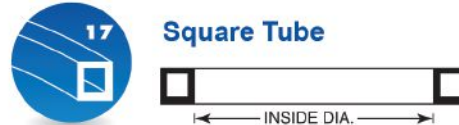
**17 Square Tube**  
 24" x 1<sup>1</sup>/<sub>2</sub>" Tube

**18 Rectangular Tube The Easy Way (Y-Y Axis)**  
 20" x 12" x 5/8" Tube

**19 Rectangular Tube The Hard Way (X-X Axis)**  
 20" x 12" x 5/8" Tube

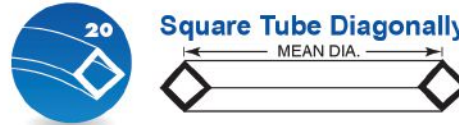
**20 Square Tube Diagonally**  
 12" x 5/8" Square Tube

**21 Round Tube & Pipe**  
 24" Sched. 80 Pipe

**22 Round Bar**  
 All Mill Produced Sizes

We also roll stair stringers, helical hand rails, off-axis bends, formed shapes and extrusions.

Visit [cmrp.com](http://cmrp.com) for more information.



**CHICAGO METAL**  
**ROLLED PRODUCTS COMPANY**

CHICAGO • KANSAS CITY





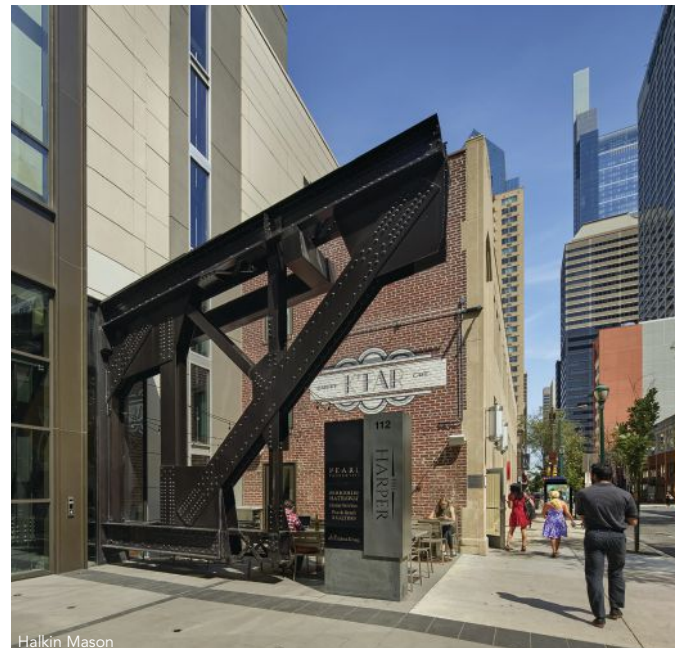
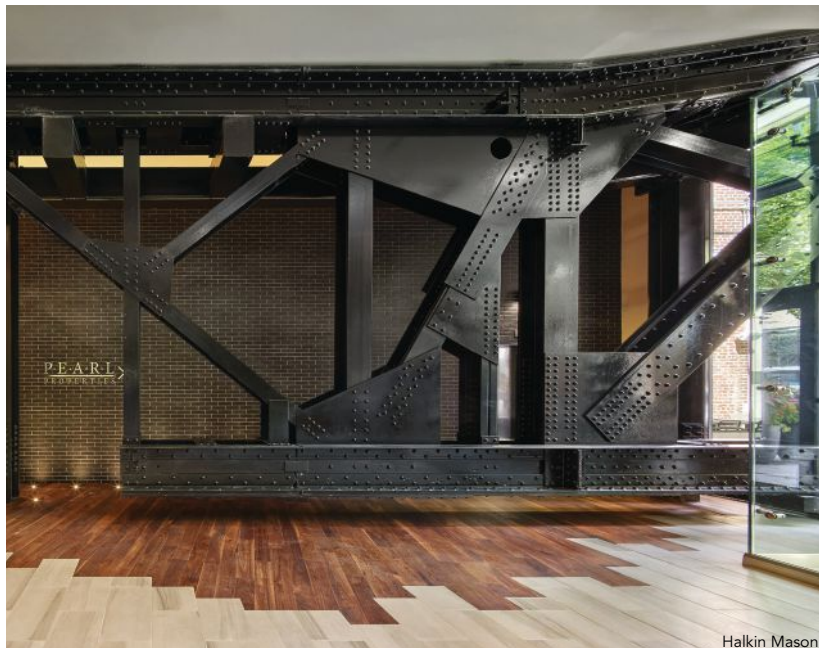
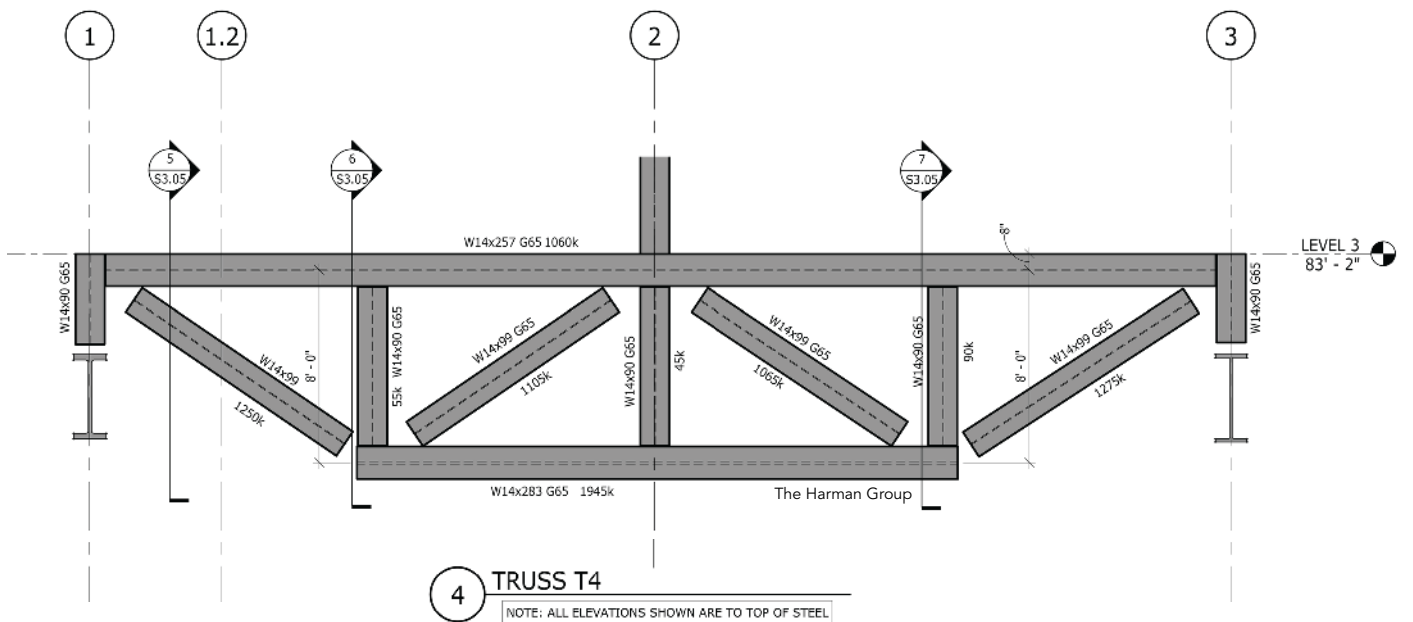
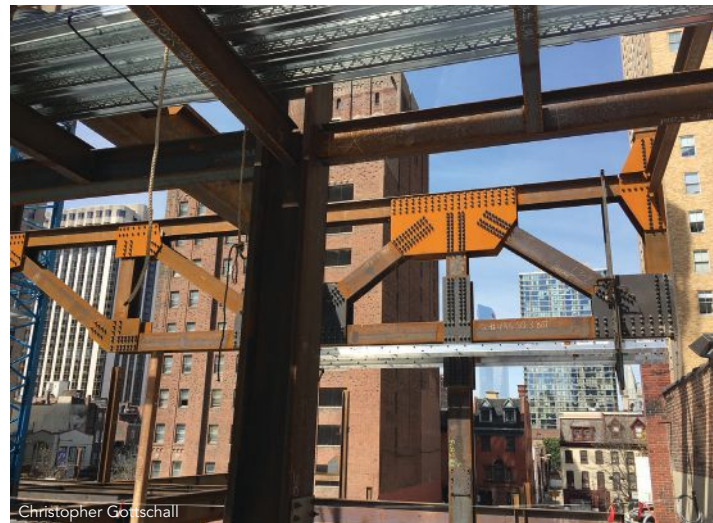



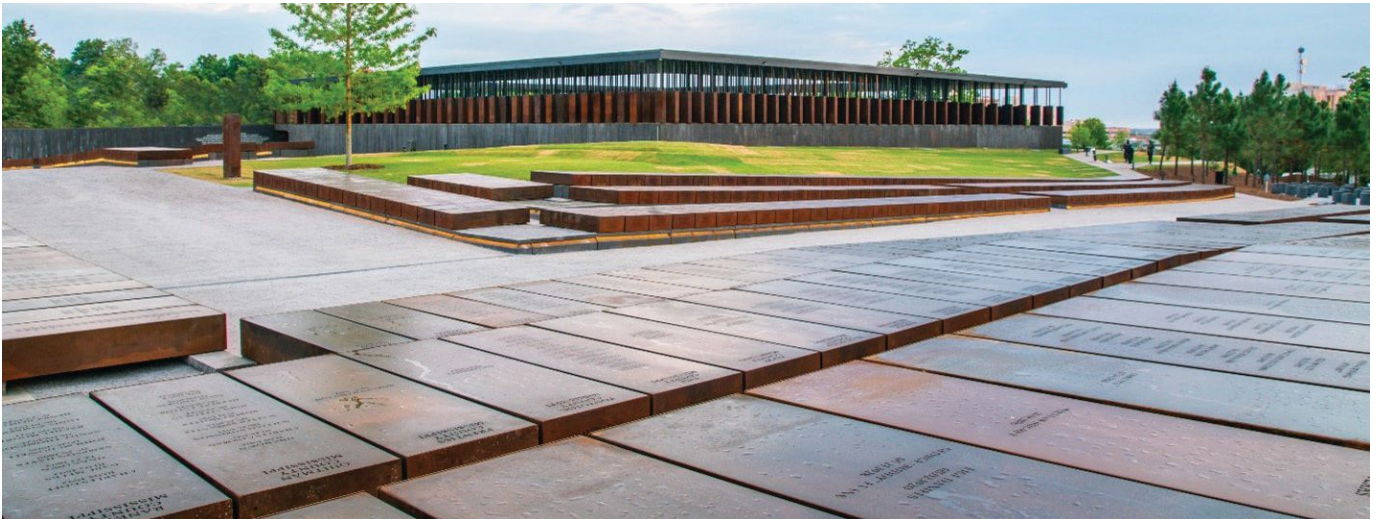

All photos: Omar Garza

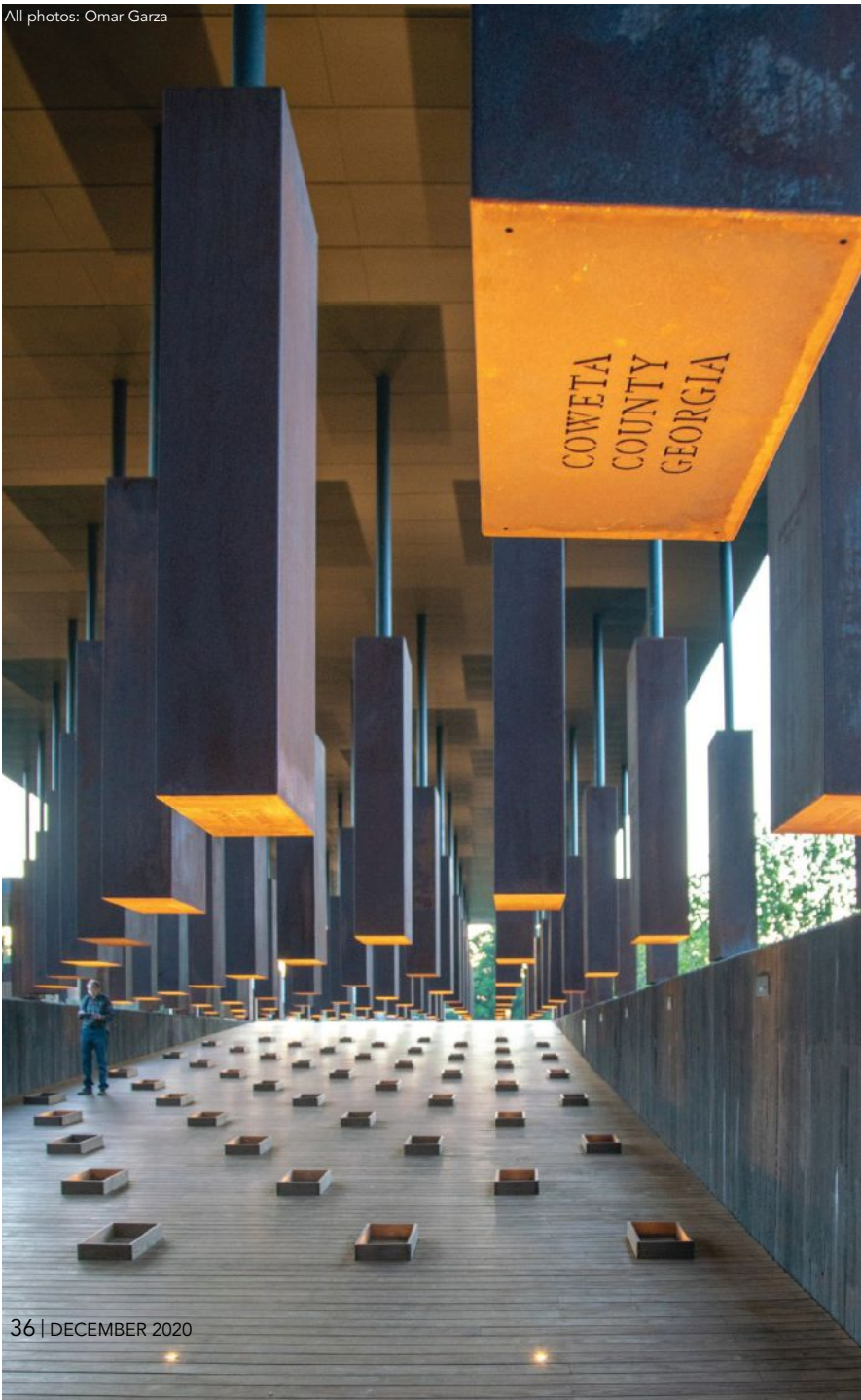

### Cool Memorial

The National Memorial for Peace and Justice, created by the Equal Justice Initiative (EJI) and located in Montgomery, Ala., is the first national memorial to victims of lynching. Featuring upwards of 800 suspended modules, each representing a county where lynchings took place, the steel structure memorializes the names of over 4,000 innocent African-American victims. The memorial communicates a raw emotional frame of reference for visitors via the exposed, unvarnished materials from which it is built.

The design intent asked for the structure to perform precisely while not distracting from the message. The structure needed to be indistinguishable from the visual narrative. Nous Engineering, the structural engineer for the project, prioritized the design with an emphasis on a thin roof profile, a uniform column dimension, and control of deflections of both the roof framing and suspended modules. Strict deflection criteria were maintained to ensure a visibly clean horizontal plane. The solution included a combination of member size optimization, camber, framing configuration, and adjustment capabilities built into the module attachments—all of which allowed for precise control of the roof level and module alignment. The building's steel framing system, including the vertical hangers from which the modules are suspended, was fabricated, erected, and detailed by AISC member Garrison Steel Fabricators.

The memorial roof is supported primarily along the perimeter foundation walls with 3.5-in.-diameter solid steel posts spaced at 10 ft to 20 ft on center. The load-bearing posts carry vertical loads and provide lateral stability. Ultimately, a balance



was struck between loadbearing columns and the hangers supporting the 300-lb suspended modules such that the same size pipe profile could be used, a critical aspect of the visual narrative. For the module construction itself, a variety of materials were considered, including fiberglass, glass fiber-reinforced concrete (GFRC), and weathering steel plate.

The team decided on weathering steel plate based on both its structural reliability and appearance. The sheer number of modules created another challenge from a constructability standpoint. The position of each module in plan was based on a non-orthogonal array parametrically driven by the architect, Mass Design Group. To manually delineate coordinates of each module in plan would have been tedious and error-prone. Further, as historical research continued during design, more counties and more modules were added. Nous Engineering generated a parametric control within Autodesk Revit to allow for EJI and the architect to add to and reorganize the 800-plus modules in a configuration that satisfied the memorial experience. The in-house dynamic tool was used by the contractor to fabricate and identify the final positioning of each module part number to streamline organization and installation.

While the monument structure is the focal point, the six-acre site as a whole serves as a restorative landscape. Where once there was an abandoned lot, there now lives a heartbreaking memorial whose narrative leaves visitors with both deep sadness and an unmistakable and unshakable feeling of hope.

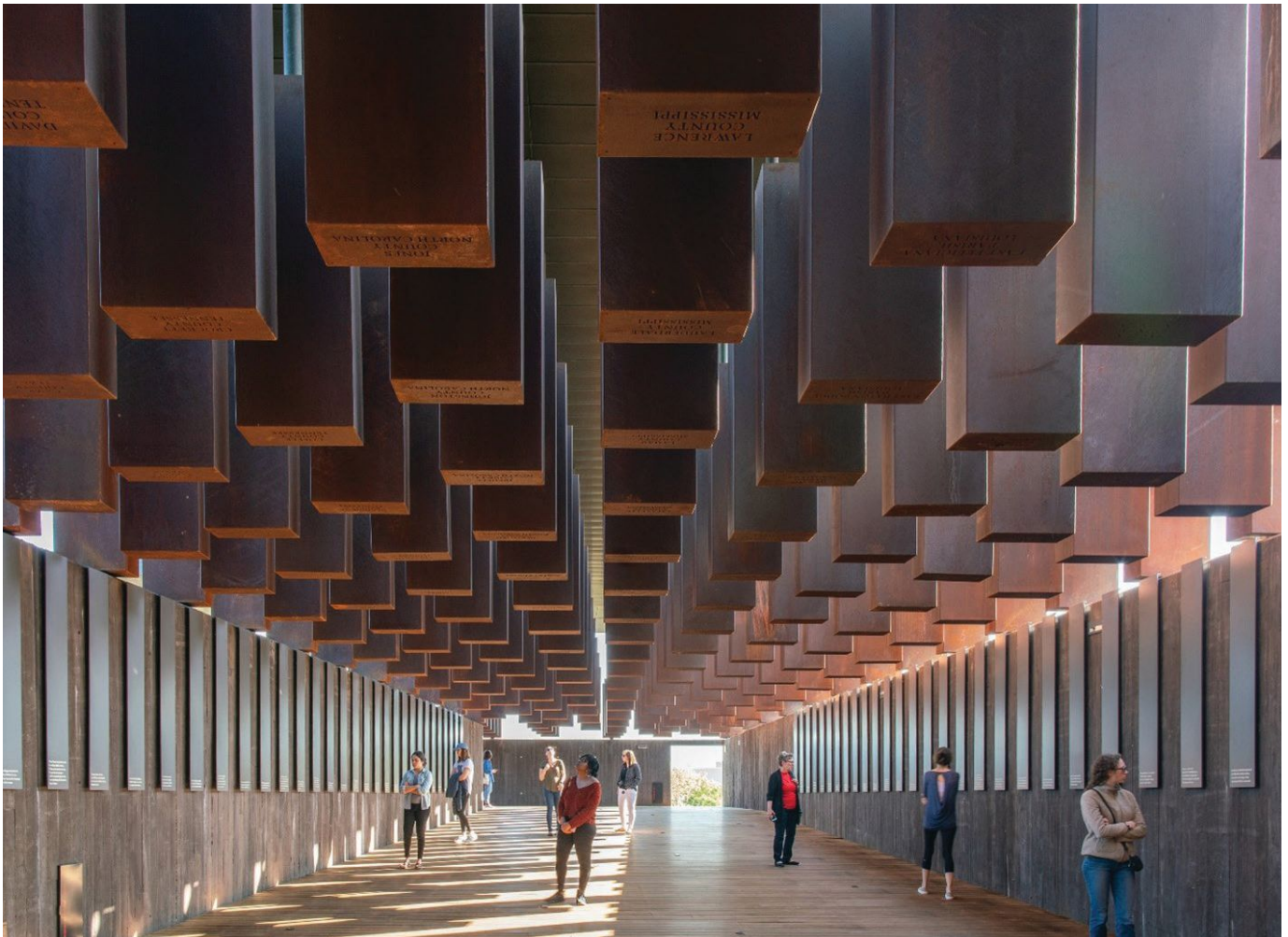
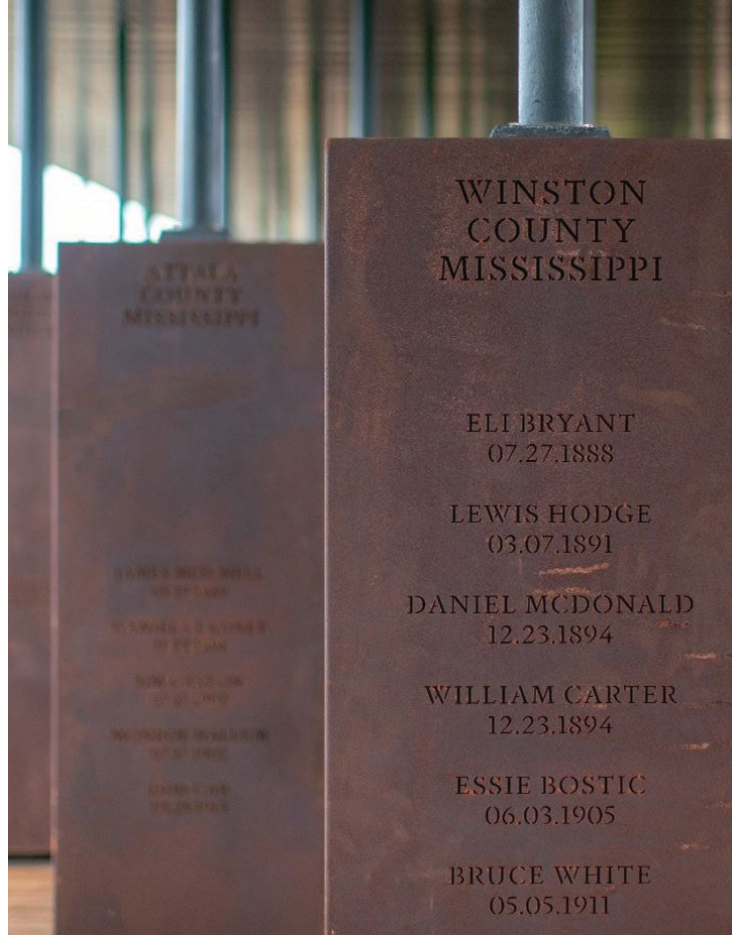



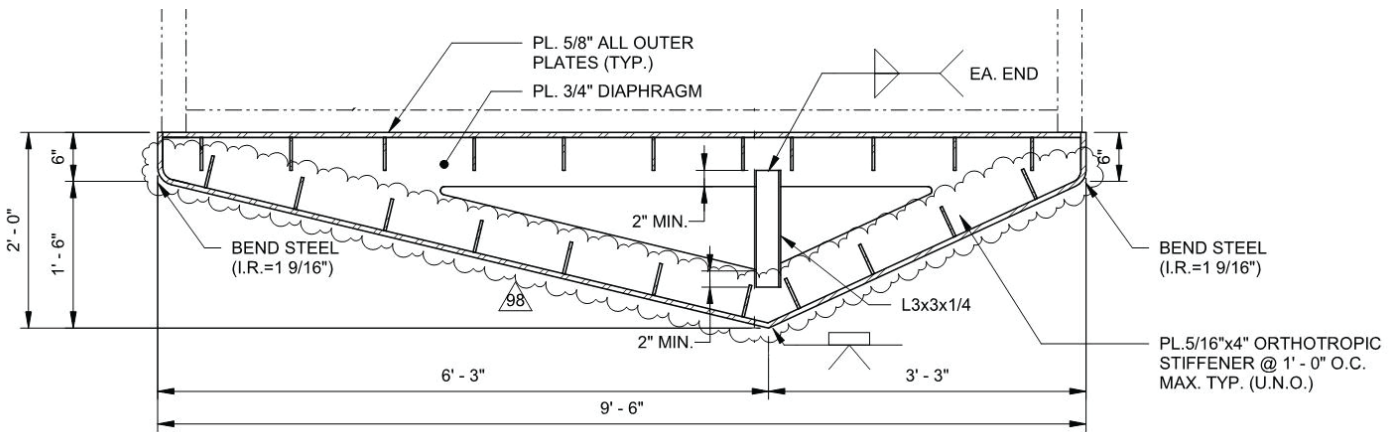

1 BRIDGE SECTION AT DIAPHRAGM AT MAIN SPAN

S540 3/4" = 1'-0"







## Cool Approach

Visitors to the John F. Kennedy Center for the Performing Arts in Washington, D.C., have a new way of reaching the arts in the form of a new asymmetrical steel-framed pedestrian bridge.

The bridge is part of a new expansion to the Kennedy Center called the REACH. Though it complements the pavilions that are the centerpieces of the REACH, the bridge does not bear on or transmit any load to the building. The bridge's main span has a 35-to-1 span to depth ratio—its superstructure is an asymmetric V-shaped steel box section with orthotropic stiffeners and open and closed diaphragms. Its thin profile—only 2 ft deep at the thickest point of the superstructure—maximizes views from the buildings to the waterfront and vice versa.

Given its location over Rock Creek Parkway adjacent to the Potomac River and its intended use, vibration and wind considerations were especially crucial to the success of the project. Therefore, structural engineer Silman's understanding of potential pedestrian-induced vibrations—as well as movements and accelerations caused by wind events—was extremely important, especially given the bridge's asymmetrical section and extreme lightness. Silman worked with wind consultants RWDI in the early phases of design to develop several strategies to mitigate pedestrian induced and vortex shedding vibrations. A decision was subsequently made to employ a series of tuned mass dampers (TMDs). In total, five TMDs, manufactured by Taylor Devices, were used within the closed asymmetrical V-section.

Early design team involvement with fabricator STS Steel (an AISC member) was key to improving constructability and reducing schedule and cost. Although the steel wasn't designated as AESS, STS suggested making a mockup (a typical practice with AESS assemblies) given the high profile of the project. This aided Silman and project architect Steven Holl Architects, who made multiple visits to STS' shop in Schenectady, N.Y., in developing details to meet design and aesthetic criteria while also controlling weld distortion and improving constructability. One such detail was actually a modification to the steel superstructure's original design, which featured sharp edges using welded plates. These were changed to bent plates, resulting in a smoother look.

The bridge is supported on five concrete piers and an abutment located at the base of its ramp. Rather than the bridge bearing directly on the piers, it rests on a steel knife plate assembly, which includes a 4-in.-thick vertical plate projecting upwards from the center of each pier. The knife plates are fixed to the tops of the piers with embedded base plates and welded rebar. The deflection of the bridge's main span and cantilever was critical in maintaining proper roadway clearance and slope, especially at the bridge-to-building connection. The main span's vertical deflection is approximately 2.1 in., and the cantilever end has a total range of vertical movement of approximately 1.1 in.

The bridge's asymmetry also complicated support locations, with one of the bearings typically in tension and the other typically acting in compression. The bearings have several unique loading and restraint conditions and are integral to the overall stability and movement of the superstructure. Pier 1, the location of the main span cantilever support, required a bearing that offered uplift restraint while also accommodating cyclical tension and compression loads under service conditions. Pier 2 is located at the "knuckle"—the 106.5° skew in the bridge—and Silman determined that movements here required a single bearing that offered restraint along the main span's longitudinal axis and movement along the ramp's longitudinal axis.

Despite the overall bridge assembly occurring over several days, the design and construction team managed to keep the Rock Creek Parkway closure to only three days. The final assembly of the main span, cantilever, and knuckle was completed on the ground adjacent to the parkway several days prior to erection.



## Cool Point

Hunters Point South is an ambitious waterfront park in Long Island City, Queens, with transformative goals and amazing views of the Manhattan skyline.

Structural engineer Arup worked with the New York City Economic Development Corporation as prime consultant and engineer on the project—designed by architects SWA/Balsley and Weiss/Manfredi—to morph this former industrial site into a sustainable and vibrant urban neighborhood.

A stunning centerpiece to the park is a cantilevering steel viewing overlook, which juts out almost directly over the East River with spectacular views of the Manhattan skyline. Smart and careful structural design resulted in a robust structure that is as economical as it is impressive. The elevated deck is a 51-ton steel truss structure with a 40-ft cantilever consisting of two side trusses laced together at the top and bottom. Each side truss was designed as three planar trusses that could be easily manufactured, transported, and erected, each individually shipped and assembled on-site to create the curved plan.







All photos: Aup





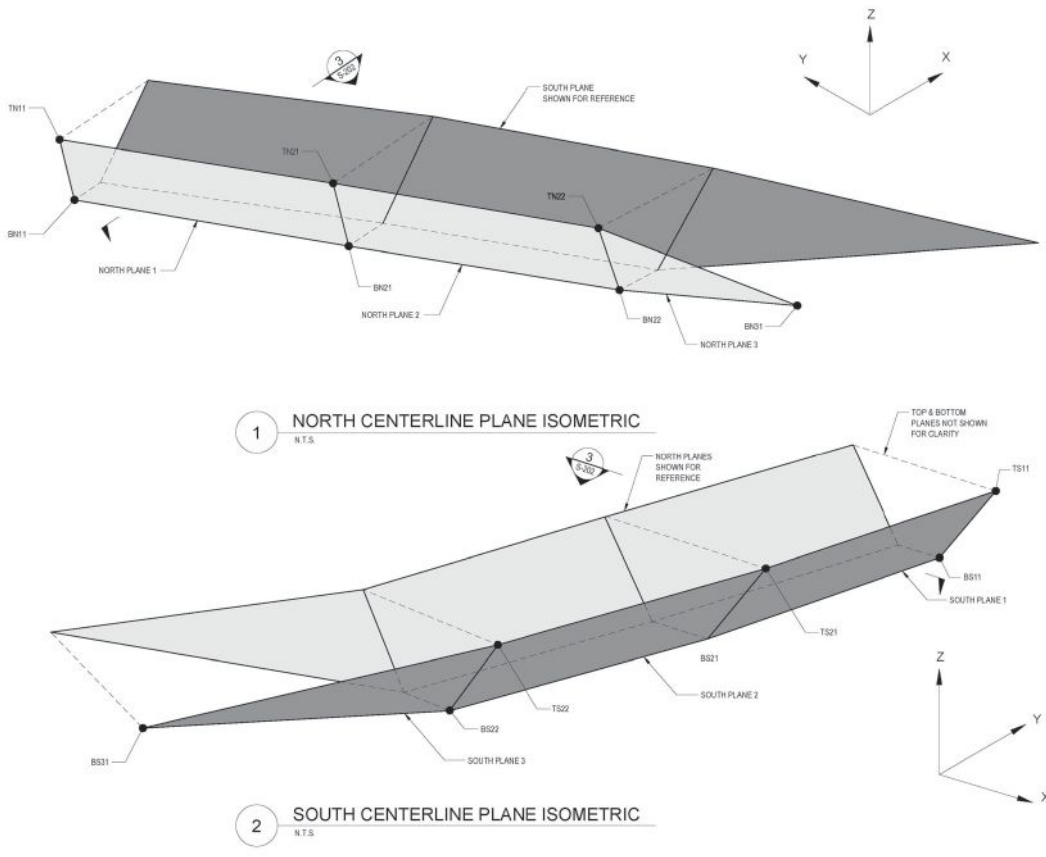

The structure is 7.5 ft at its deepest, tapering to 6 in. at its 36-ft-wide edge. The length of the trusses was determined by trucking length. The individual planar trusses were assembled on the ground, and the entire structure was lifted and placed onto the foundations as one piece. The design allowed for an optional erection sequence of the entire lift, as was done, or for just the back span to be assembled and lifted and the cantilever portion to be lifted and bolted as a second piece. Consideration of this erection sequence was important as propping of the cantilever steel during construction would be difficult, if not impossible. The cantilever extends over new wetlands and marine works, which were built before the steel installation.

The outside of the overlook is clad in 36 tons of faceted architecturally exposed steel (AESS). The choice of steel as cladding material allowed for large panel sizes without oil-canning or other distortions, which can come

# Eliminate Field Welding!

“Crossland Construction was in love with how fast SidePlate went up on this job. In fact, they are already planning to use SidePlate for the other upcoming Founders Plaza buildings which will go nearby.”

*-Christopher E. Lang  
Senior Project Manager  
Tatum Smith Welcher Engineers  
Rogers, AR*

949-238-8900  
www.sideplate.com



*Founders Plaza, Rogers, AR*





All photos: Arup

from other materials. The steel cladding also emphasizes continuity with the first phase of the park (opened in 2013), which features a folded steel plate roof canopy.

The facets in the cladding help to achieve the curve, and it's truly an example of a smart, cost-effective use of AESS. Using the same fabricator as the main structure and the handrails (Newport Industrial Fabrication, Inc., an AISC member) provided project and visual continuity. The team also specified AESS tolerance requirements for some non-exposed areas in the hidden structure, meaning the unseen portion of the overlook would have tighter tolerances and function just as the exposed structure did, resulting in a much nicer end product.

A structure like this faces a variety of uses: a few people walking, a crowd gathered to watch fireworks, or even people jumping. Arup's Advanced Technology and Research team performed a detailed vibration assessment of the design-stage models and also tested the overlook while it was under construction, in an effort to best inform the client of their choices. Based on the analysis, a decision to include tuned mass dampers was made in conjunction with the client to provide enhanced vibration performance under a variety of load conditions.

Adding further complexity to the project, the park is largely built on spoil from past construction projects, including the Midtown Tunnel. Fill and spoil are not known for offering any benefits to structural support, so the project relied on piles and other smart solutions to ensure structural stability. The team worked to limit the number of required piles, thereby remaining as cost-effective as possible in light of the site challenges—and using a steel structure allowed for a more economical, lower-weight solution than other materials.

See the *Project Extras* section at [www.modernsteel.com](http://www.modernsteel.com) for additional photos and information on the fabrication process.

@

# ABL-100HS

## Angle Line

The only angle & flat bar line holding the title for both toughest build quality and fastest speeds.

**Controlled Automation**

501.557.5109 | [www.controlledautomation.com](http://www.controlledautomation.com)





All photos: © Billy Hustace

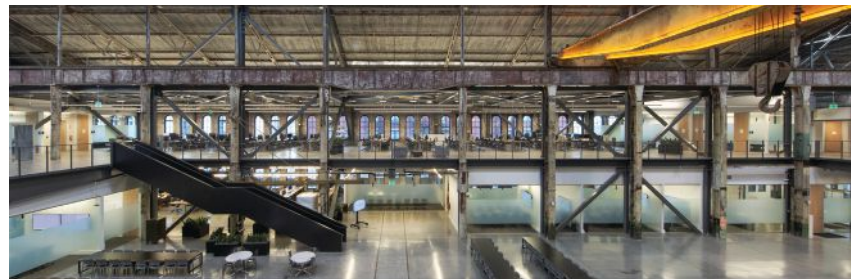

### Cool Transportation Transformation

Uber Advanced Technologies Group is a self-driving technology engineering team whose Research and Development Center is housed within San Francisco's historic Pier 70. The former home of Bethlehem Ship-building, the seven-acre site once hosted important 19th- and 20th-century naval innovations and is on the U.S. National Register of Historic Places.

Years of abandonment, vandalism, earthquakes, and exposure had made the buildings dangerous. Four massive buildings, derelict and inaccessible for decades, now extend the site's legacy of transportation endeavors into the 21st century. The site's history as a shipyard, interconnected with the commerce, technology, and transportation of its time, makes it a fitting home for Uber.

The client and the developer, Orton Development, Inc. (ODI), foresaw that the industrial structures, once adapted, would serve Uber's specific needs for industrial, research, and office spaces under one roof. The contiguous buildings originated in different decades and are of varying construction types and materials, including unreinforced masonry, reinforced concrete, and wood or steel trusses.

Designed by Marcy Wong Donn Logan Architects, Mark Hulbert of Preservation Architecture, and structural engineer Nabih Youssef Associates, in close collaboration with ODI, the approach uses a (new) building-within-an-(old) building concept to preserve the historic perimeter walls while retaining the lofty volumes of the industrially scaled spaces. A major challenge in earthquake zones is the seismic deficiency of older buildings. The new retrofit system is designed to resist a 500-year earthquake. Steel columns and braces are strategically located along the existing structure to minimize visual impact. New composite steel and concrete mezzanines not only add leasable area but also brace the historic brick walls at mid-height. Full-height steel stud walls have upper portions sheathed in clear, multi-wall poly-carbonate to maintain original sightlines.

Demising large industrial spaces with steel (fabricated by AISC member Kwan Wo Ironworks) and transparent glass walls preserves the spatial character of the industrial building while also separating tenants. Conference rooms and other programmed functions are new freestanding elements within the



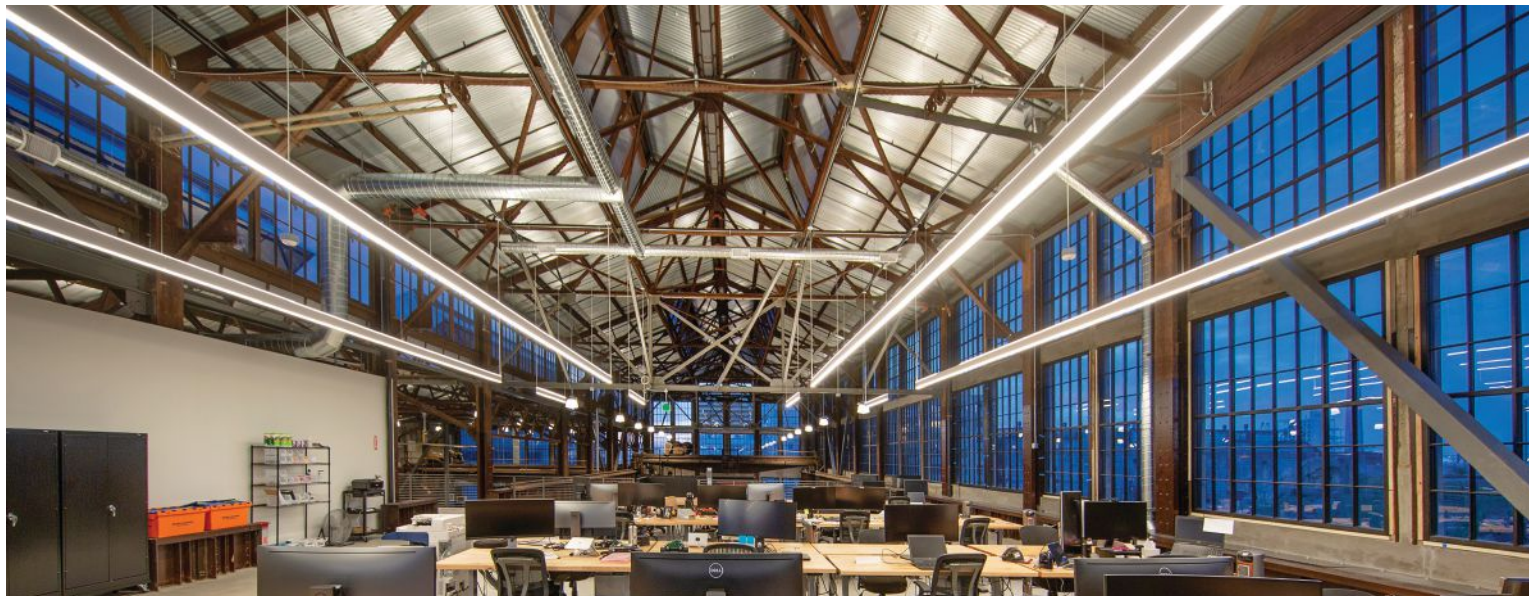

large volumes. Lab, shop, and kitchen spaces are located under mezzanines, allowing for control of noise and temperature and containing dust while preserving the voluminous center of shared social space. The site benefits from the Bay Area's temperate climate, and so natural ventilation is enhanced within the buildings and is supplemented, when necessary, by ceiling fans and radiant heat.

Historic facades and suspended cranes frame the cavernous industrial spaces. Notably, the existing structural steel columns, beams, and trusses are left natural or protected with transparent coatings where needed. New structural steel and architectural elements stand in clear yet compatible contrast to the historical ones. With abundant natural light and ventilation, the new spaces enable multiple modes of working and interacting, including individual desks, conference rooms, group work areas, vehicle testing and storage, shops, kitchens, and event spaces.

Architectural lighting, designed in collaboration with Architecture and Light, shapes the spaces, defines functions, and highlights emblematic industrial artifacts (such as the original yellow

steel cranes). Other features include steel bridges shaped to replicate the original steel gantry cranes, connecting spaces between mezzanines such as conference rooms, private office, open office space, sound-isolated areas, and a research and design shop for the vehicles. The mezzanine bridges spanning the open interior area are supported by tapered beams and feature a stainless steel cable guardrail system. Rehabilitation of the deteriorated building shell also includes the refurbishment of the existing steel roof structure, relocation of the steel gantry crane to the tenant space, and reconstruction of the continuous ridge skylight.

The buildings were designed around daylit factory floors, making the most of the project's sunny, waterfront location. The design team and ODI exploited the daylighting opportunities of the original buildings, uncovering and restoring hundreds of broken or boarded-up windows and repairing skylights. In a particularly effective example of value engineering, the architect collaborated with the developer and specialty contractors to reduce the cost of the 58-ft-high steel-framed glass walls to one-third of the original estimates.



## Cool Creek Crossing

Central Park has long been the beating natural heart of Boulder, Colo. The city recently approved a new master plan to update this popular green space along Boulder Creek.

The landscape architects at Tom Leader Studios (TLS) were instrumental in helping the city develop its vision, which included a new, wider pedestrian and bike bridge in the middle of the park, helping to improve flow and connect the downtown area to the University of Colorado campus and surrounding neighborhoods.

Working in collaboration with AISC member fabricator Bridge Brothers, which designs, manufactures, and installs prefabricated bridges, they created a modern yet rustic steel bridge design that blends seamlessly with its surroundings and highlights the area's natural beauty.

“TLS presented us with several different design concepts, and we came together on a design that emulated their original design concept and really seemed at home in the environment,” said Elias Angell, Bridge Brothers’ president. “It was also cost-effective and presented us with the opportunity to use our innovative manufacturing techniques.”

At a total weight of 145 tons, including 72.5 tons of weathering steel, the bridge has two spans, the longer of which is 99 ft, and crosses Boulder Creek. The side panels, which are made of solid steel plate with a Moiré pattern cut into them, serve as a truss that helps carry the load of the bridge, allowing it to handle up to 90 lb per sq. ft of pedestrian traffic and vehicles up to 5 tons.

The deck of the bridge consists of 6-in.-thick concrete on top of steel bracing. Steel grating rated for heavy vehicular loads



All photos: Bridge Brothers





was also placed intermittently, giving pedestrians and cyclists a view of the creek below. The splice joint connecting the two spans was designed to be hidden as much as possible, and LED lighting was incorporated into the handrails to make the bridge glow at night, improving safety and highlighting the bridge's design features.

The bridge spans were assembled entirely off-site. With all the connections pre-fit in Bridge Brothers' shop, including lifting lugs, the bridge simply had to be lifted into place and secured to the footings.



**EARTHQUAKES STADIUM**  
Home of the San Jose Earthquakes

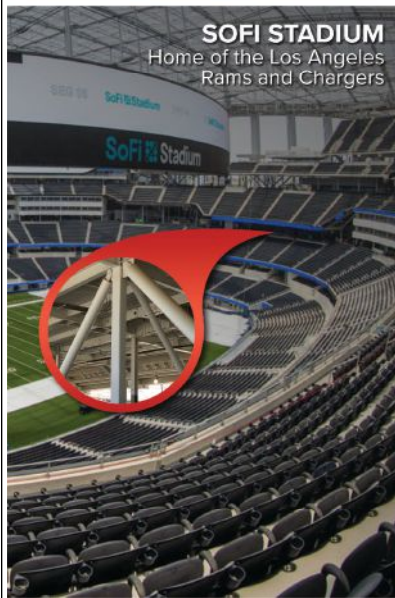

**SOFI STADIUM**  
Home of the Los Angeles Rams and Chargers

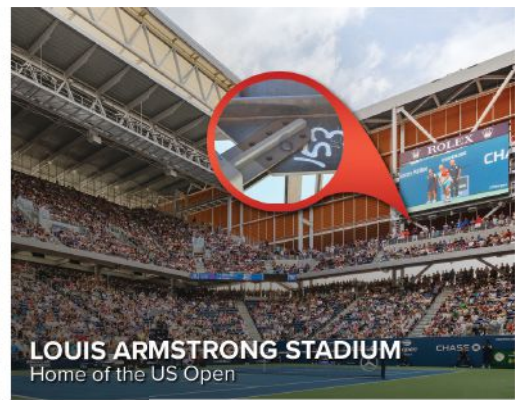

**LOUIS ARMSTRONG STADIUM**  
Home of the US Open

**BUILD SMART  
PLAY HARD**

BRBs protect cool sporting venues all over the US.

**COREBRACE**  
SUPERIOR SEISMIC PERFORMANCE  
[www.corebrace.com](http://www.corebrace.com) | 801.280.0701

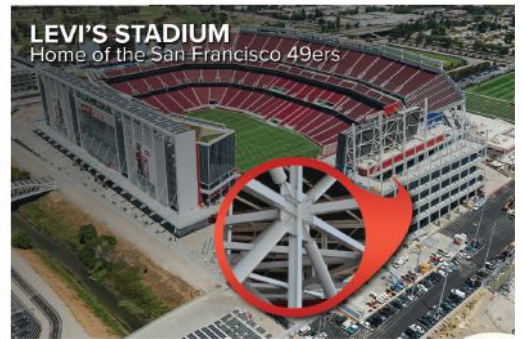

**LEVI'S STADIUM**  
Home of the San Francisco 49ers

**THE PROVEN  
STEEL BRIDGE  
DESIGN SOLUTION**

**FREE  
15-DAY  
TRIAL\***

\*see website for details



The leading software package for designing and rating curved and straight steel girder bridges.

**Used by Many State DOTs and Top Design Firms**

(573) 446-3221 ■ [www.mdxsoftware.com](http://www.mdxsoftware.com) ■ [info@mdxsoftware.com](mailto:info@mdxsoftware.com)



### Cool Sculpture as Vine Arbor

Belvedere is a sculptural steel crossroads of sorts in southern Germany.

Located at the intersection of several vineyards on the Kappelberg hill above the village of Fellbach, just east of Stuttgart, Belvedere is one of the “16 Stationen” (16 Stations) projects built for the 2019 Remstal Gartenschau (Remstal Garden Show), the country’s first intercommunal garden show, which is set in the Rems River valley.

Designed by Barkow Leibinger, the circular pavilion—framed with 3-in. round HSS—serves as a spot to rest, enjoy the view, and drink the local wine. The pavilion also functions as an appealing location for larger events like wine tastings, winemaking presentations, photoshoots, or wedding ceremonies and receptions.

The “roof” of the painted steel pergola is a modern metal take on a vine arbor, yet it is also reminiscent of a cloud—especially on clear days when it is framed by crystal blue skies. The white paint refers symbolically to the colors of the nearby chapels. The roof construction, designed in cooperation with Werner Sobek, rests on steel columns and consists of steel elements that are intertwined to form a space frame. As a filigree structure, the pavilion marries an ancient typology (the pergola) with a contemporary aesthetic.

Recalling an earlier work from the 1950s by the visionary architect and engineer Konrad Wachsmann (“Grapevine Structure”), Barkow Leibinger’s design revisits and updates Wachsmann’s concept. The utopian ideal of a subtle jointless space frame is transformed into a woven geometry of curved metal profiles; the HSS are bundled together to form the columns and root the entire structure to the ground.

Over the years, wild vines will climb up the columns and extend over the structure, creating a dynamic and organic character that will, as time passes, accord more and more with its surroundings.



© Iwan Baan



© Iwan Baan



© Iwan Baan

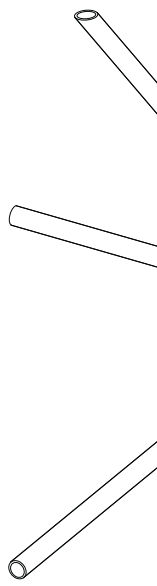





© Iwan Baan

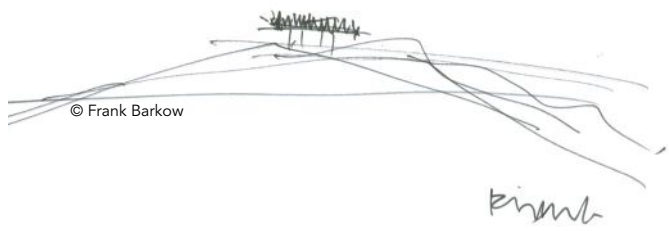

© Frank Barkow

kinmb

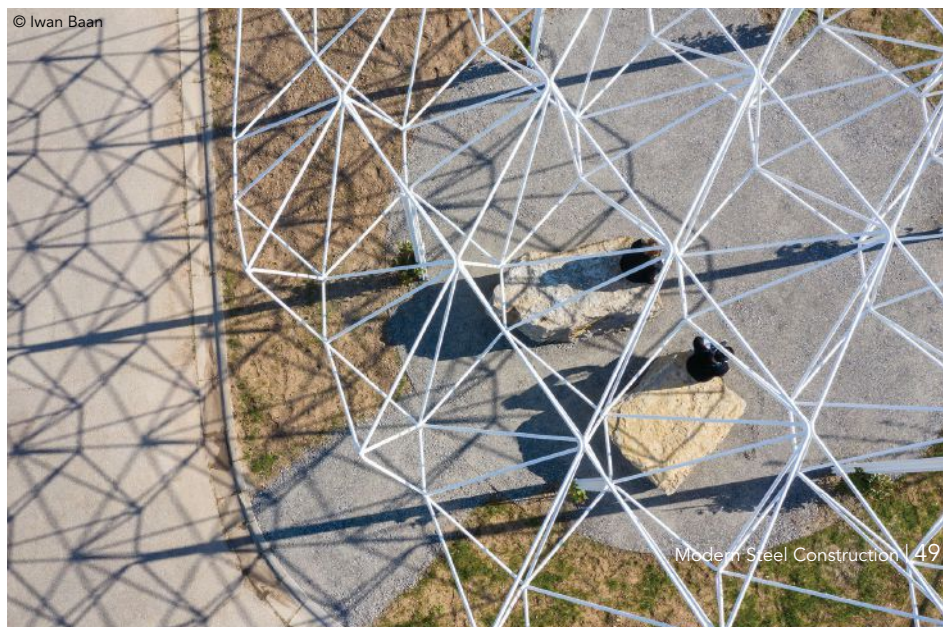
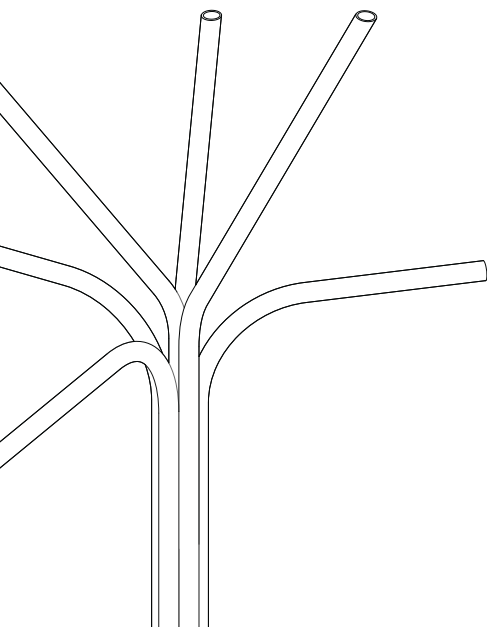

© Iwan Baan





## Cool Nuclear Test Site

Story and photos by Zach Liollo,  
owner and director of R&D, Construction Automation, LLC

Las Vegas is known for its energy.

But for more than four decades, a site roughly 75 miles north of the famed entertainment mecca saw its fair share of energy as well—in the form of 928 nuclear test explosions.

The 600-sq.-mile section of desert, known as the Nevada Proving Grounds, began seeing use as a bombing range in 1941. Run by the U.S. Atomic Energy Commission (AEC), it was used for continental testing and evaluation of new nuclear devices and components, as well as the effects of these devices on civil and military targets. The detonations were kept under a certain yield limit that would be considered paltry compared to today's strategic nuclear weapons.

In 1977, the testing grounds saw some dramatic changes in terms of administration, as the AEC was absorbed by the U.S. Department of Energy (DoE), which continues its stewardship to this day. And in 2010, the site was renamed the Nevada National Security Site (NNSS) to reflect its ongoing mission. While still in use as a test site, it no longer hosts nuclear explosions. However, archaeological evidence from its first decade of atomic testing remains nearly pristine—and much of it is structural steel.

Since its inception, construction professionals and tradespeople have tackled a variety of complex steel construction projects at NNSS, from 1940s-era Quonset huts to large steel towers to racks laden with measuring devices. Specialized engineering and fabrication—performed on-site—are required for much of the scientific equipment, which can vary from test-to-test.

Due to ongoing security concerns, public access to NNSS is restricted, and no soil or material can be removed from test areas. Tours via bus are available, but cameras, cellphones, and measuring instruments are not permitted. However, I received special media clearance, and a DoE escort, to photograph the former nuclear testing site.

After entering the site's front gate at Mercury, Nev., there are miles of two-lane roads stretching into the desert expanse. After some 30 minutes of driving beyond the front gate, Yucca Flat presents a vivid glimpse into America's atomic nightmare. A 1955 test series, "Operation Teapot," included the construction of a "Survival" or "Doom Town." (It should be noted that for many tests, especially early on, names were selected from a list of code words.) Two houses, scorched and rattled by the blast, survive to this day. This test, like many ground-level tests, used a steel lattice "shot





tower” to hold the device and measuring equipment. In the pre-fiber optic era, trunks of cables ran vertically down the tower to distant trailers, huts, and the test’s control point. While it once soared over the desert like a mighty drilling derrick, much of the steel tower was obliterated milliseconds after a test device was detonated—what is known as “zero time.” Twisted guy wire stanchions and scorched concrete footers are all that remain.

A similar type of effects testing occurred at the adjacent Frenchman Flat. These atmospheric tests spanned almost the entire decade of the 1950s, and the specific targets and devices varied widely. Frenchman was also the site of “Upshot-Grable,” which tested the 15-kiloton-yield W9 warhead. The M65 artillery piece that fired it was known as “Atomic Annie,” its design derived from the German K5 railway gun.

Extant in the blast-swept plane are curious, dome-shaped structures. Many of these are reinforced concrete, ranging in wall thickness of 2 in. to 8 in. Aluminum structures (½ in. to 1 in. in wall thickness) of a similar geometry—mock bomb shelters built by American Machine and Foundry Company—were subjected to what was known as the “Priscilla” test in 1957—and were flattened and torn asunder by the blast.

The mock bomb shelters tested new designs for survivability. While some of the domes remain intact, others were peeled back like eggshells, revealing a twisted mass of rebar.

A lone bank vault stands in the middle-ground, its east and west elevations bristling with bent rebar. Designed by Mosler Safe Company of San Francisco, it too was part of the Priscilla test. This structure is stout; the rebar used appears to be size number 9 or 10. Evidence of the vault door being torch-cut can be seen. Some debris litters the interior, which is now open to the environment. The purpose of this relic was to test the resilience of currency and vital records in a nuclear war.

In the adjacent Frenchman Flat, the tests focused primarily on military effects testing. Near the ground zero spots for the Encore and Grable tests (conducted in 1953) stands a riveted steel railroad bridge with concrete piers. Erected by U.S. Army construction engineers, this bridge was to be a “typical” railroad bridge. Perhaps most striking today are the centermost beams and horizontal bracing. The heat and blast damage appear as if it was shaped by a blacksmith. Clip angles were sheared nearly at the k-area. But what really defines this relic, besides seeming to defy physics, is that the steel bridge still spans between two piers. Traveling west,





it becomes apparent that seven more piers remain. I noticed a rivet in the sand whose driven end had been cleanly sheared off. (With radiation still present in many of the steel artifacts, I decided to leave it undisturbed.)

With concerns of war erupting once again in the late 1950s, the Army was especially interested in structures like bridges. Having fought

**NEW!**

**ACCELERATING  
YOUR  
PERFORMANCE**

**voortman**

VOORTMAN STEEL MACHINERY

ALL-IN-ONE  
MACHINE  
DO IT ALL IN  
A SINGLE  
PASS!

**IN STOCK NOW!**

- ▶ FINANCING AVAILABLE
- ▶ FASTEST ROI



**VOORTMAN  
V807**

ROBOTIC THERMAL  
PROFILE PROCESSOR

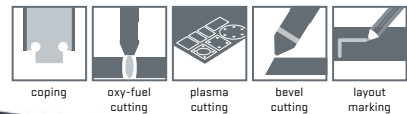

**NEW DESIGN;  
SAME PRODUCTIVITY**

- ▶ Footprint reduced 50%
- ▶ Fully automated processing from loading to unloading
- ▶ Copes, rat holes, slots, block outs, seismic connections, layout marking and more
- ▶ Capable of plasma and oxy-fuel cutting; quickly change torch lead sets

**voortman**

**VOORTMAN USA**

26200 S. Whiting Way +1 708 885 4900  
Monee, IL 60449 info@voortmancorp.com  
United States of America www.voortmancorp.com





tooth-and-nail less than a decade earlier to cross the Rhine River, military engineers were fully aware of the bottlenecks that transportation posed. Tactical nuclear weapons would only exacerbate this challenge. To fully understand their impact, locomotives, rolling stock, and myriad vehicles were likewise exposed to heat and blast. Even today, leftover railroad boxcars are readily spotted around NNSS.

Above-ground testing posed many security issues, especially in regards to observers. In January of 1956, John Malch (U.S.A., retired) witnessed a test in Area 11d near Frenchman Flat. He was on sentry duty, just after midnight, in Camp Irwin, Calif. Despite the distance, a fireball flare briefly illuminated the black horizon. Upon reporting the strange occurrence, he was ordered to keep the incident secret and strike all written records of it.

Atmospheric testing came to a permanent end with the Limited Test Ban Treaty in 1963. However, starting in the late-1950s, underground testing had commenced. The dawn of the new decade saw a world on the brink of doomsday. New technology was tested to counter the Soviet Union's advances in rocketry, which was reciprocated with ever more powerful weapons. Despite heightening tensions, a peaceful use for nuclear technology was also sought. This led to the creation of the Project Plowshare program for developing techniques for using nuclear explosives for construction purposes. (The name itself is a Biblical reference, based on the concept of turning swords into plowshares.) In 1962, the Storax Sedan test, under the program, created the largest man-made crater in the United States—330 ft deep and 1,280 ft in diameter—displacing 11,000,000 tons of soil.

Today, the crater is as intimidating as it ever was. The stanchions from the tower used to lower the explosive device underground are still in place, though partially destroyed by the explosion. The depth of the crater can be viewed from the platform. Recently, a new platform was fabricated to replace the older wooden one. The historic structure, built just days after the blast with dimensional lumber, is now conserved as contextually important to the Sedan Crater.

Throughout the tour, the stark, barren, eerily beautiful landscape was punctuated by multiple steel elements that, while not entirely intact, were able to withstand immense, frightening displays of energy and power—and dramatically prove their resiliency. ■



**THIS YEAR  
GET THE  
GIFT OF  
TIME**

**Reduce structural frame  
installation time by as much as  
85%  
compared to angle iron**

**QUICKFRAMES**  
The Leader in Engineered Structural Support Systems  
[www.QuickFrames.com](http://www.QuickFrames.com)



**Over the Top  
Pallet Wrap**

*The industry's toughest, most weather  
resistant pallet wrapping!*

**Protects labels & custom tagging!**

Call or email us your inquiry!  
**St. Louis Screw & Bolt**  
[sales@stlouisscrewbolt.com](mailto:sales@stlouisscrewbolt.com)  
**800-237-7059**



The winners of a student research competition  
share what they've learned about a variety of steel projects, old and new.

# Picturing the Future

**THIS PAST SUMMER**, AISC teamed up with RePicture, a virtual community where students learn about STEM careers and real-world projects while researching structural steel-related engineering, architecture, and construction topics.

Participating students were given the opportunity to show off what they learned for a chance to win awards across a variety of categories. Here are the winners of the six-week program. For more details on each winner, visit [repicture.com/explorer/projects](https://repicture.com/explorer/projects) and search on the various projects.

## EARLY SKYSCRAPERS AWARD

### The Home Insurance Building

Students must complete a project write-up for an early “skyscraper” constructed before 1940.

#### Winner: QiTong Han, Cooper Union

Chicago’s Home Insurance Building was built in 1885 as the first skyscraper in America to have a core of metal embedded in the masonry. Designed by William LeBaron Jenney, an architect and an engineer who paved the path for the Chicago School in developing the modern skyscraper, the building used a metal frame—a skeleton of vertical columns and horizontal beams—rather than traditional masonry load-bearing walls. The frame, originally designed in wrought iron, was changed to structural steel midway through construction when Jenney found that the Carnegie-Phipps Steel Company could produce high-quality steel beams and columns. The lightweight advantage of steel reduced overall building weight, making it possible to complete a 180-ft-tall structure that was less likely to collapse under its own weight compared to traditional buildings of the time.

## ICONIC AND INNOVATIVE STEEL BRIDGES AWARD

### The Bailey Bridge: A Bridge that Aided Victory in WWII

Students must complete a project write-up for a steel bridge that was innovative for its time.

#### Winner: Noran Shahin, University of Houston

In the midst of World War II, the need for temporary spans that could provide quick access across channels and rivers—and that could be used to replace bridges destroyed by German and Italian armies—brought about the introduction and development of the Bailey Bridge. Introduced in 1940 by English engineer Sir Donald Bailey, the concept was to provide a temporary bridge that could be rapidly and manually erected in war-time conditions, and that could sustain the loads of heavy tanks and other machinery. Constructed of lightweight and standardized prefabricated steel components that could be easily transported and put together using simple tools and a few army engineers, the through-type truss bridge served as a pivotal tool in the Allies’ success during the war—and was among the earliest examples of modular bridge construction.

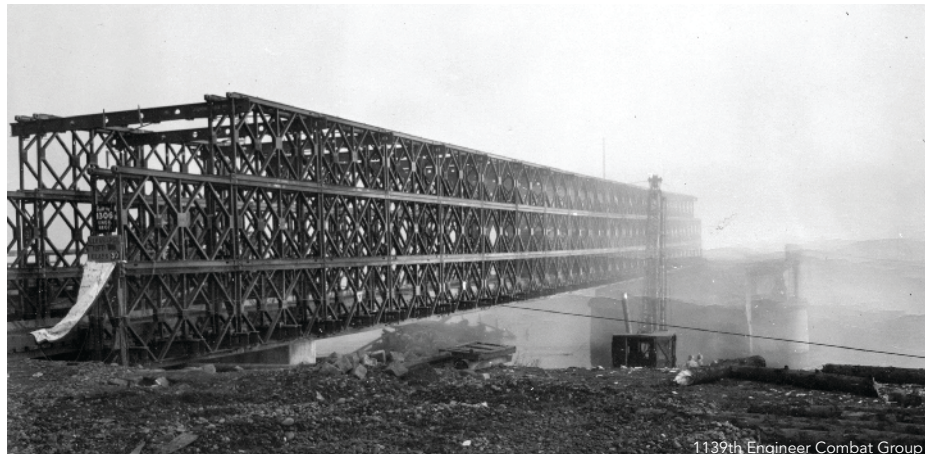



## MODULAR CONSTRUCTION FOR AFFORDABLE HOUSING AWARD

### Rockefeller University SNF-DR River Campus

Students must complete a write-up for a project that used steel for modular construction.

**Winner: QiTong Han, Cooper Union**

Rockefeller University is located on Manhattan's Upper East Side, adjacent to the East River and FDR Drive. An expansion project for the campus called for a new three-story building with two levels of laboratories. Lay-down area was limited to a 10-ft- to 15-ft-wide strip of land between FDR Drive (a major north-south traffic artery) and the river promenade to minimize traffic disruption. Building over FDR Drive was one of the project's major challenges because the roadway needed to remain open during construction. A modular construction approach and the ability to barge the steel assemblies directly to the site were the perfect solutions.

See "Barging In" in the January 2017 issue, available at [www.modernsteel.com](http://www.modernsteel.com), to read more about the Rockefeller University project.

## SUSTAINABILITY AND STEEL AWARD

### A Living Building—Phipps Center for Sustainable Landscapes

Students must select and complete a write-up on a LEED-certified building that is built with structural steel.

**Winner: Salma Shahin, University of Houston**

A spectacular example of a LEED platinum steel building is The Phipps Center for Sustainable Landscapes (CSL) in Pittsburgh. Referred to as a "living building," the CSL was designed to produce more energy than it consumes every year. This is achieved through solar panels, wind turbines, geothermal wells, a rooftop energy-recovery unit, and other elements. It also employs wetland and distillation systems to treat and recycle sanitary wastewater generated in the facility and includes systems to redistribute some of this water for irrigation.



## STEEL CONNECTIONS AWARD

### Steel Connections: The Secret to How Steel Structures Stay Together

Students must select one type of steel connection and write up the research and testing that was performed to verify it.

**Winner: Salma Shahin, University of Houston**

One example of a fully restrained moment connection is the extended-moment end-plate connection. This type of bolted connection is typically used between an internal beam (rafter) and a column in multi-story frames for buildings. It's called an extended moment end plate connection because a steel end plate (that "extends" past the ends of the beam's flanges) is welded to the end of the beam and then bolted using high strength bolts to another member (typically a column). The advantage of having an extended end plate rather than a flush end plate (that does not extend beyond the beam's flanges) is that the extended end plate allows room for bolts above and below the flanges and not just in between them. Using more bolts and adding stiffeners to the connection are common methods to increase the strength of the connection.

## STEEL BRIDGE CONSTRUCTION AWARD

### ABC: The Replacement of Nassau Boulevard Bridge in 55 Hours

Students must select a bridge constructed using accelerated construction, incremental launch, crane lift, float in, slide in, or SPMT, and complete a write-up on the bridge and construction method.

**Winner: QiTong Han, Cooper Union**

The replacement of Nassau Boulevard Bridge, located in Garden City, N.Y., along the Long Island Railroad Main Line, was completed over a single weekend. The new bridge is 39 ft wide and consists of four through-plate girders with a span length of 45 ft, 6 in., resulting in an overall bridge width of 47 ft, including a steel grating walkway on each side. The new 285-ton bridge was rolled into place with a self-propelled modular transporter, an efficient accelerated bridge construction (ABC) technique. The new bridge was shipped to the site in sections and assembled in place. After the old bridge was demolished, the new bridge was lifted and slowly rolled into place. Next, crews rebuilt the track atop the bridge and reconnected the existing tracks.

## SEISMIC DESIGN AWARD

### 181 Fremont

Students must select a seismic force-resisting system used in structural steel buildings and complete a project write-up explaining how the force works and the best applications for this system.

**Winner: Claire Ganci, Texas Tech University**

San Francisco's 802-ft-tall 181 Fremont tower was designed with a single diagonal brace on the exterior. One significant advantage of using a braced frame in this manner as opposed to in the center of the building is that it frees up space on the interior. This "mega-bracing" system spans from the ground to level 20 and level 20 to level 37, and then buckling-restrained braces span from level 37 to the roof. What makes buckling-restrained braces (BRB) unique is that they are composed of two parts: an inner core that is able to support the lateral load while deforming and an outer shell that keeps the inner from buckling. This means that the bracing on 181 Fremont is able to shorten or lengthen 6 in. during an earthquake.

See "Braced for the future" in the April 2016 issue, available at [www.modernsteel.com](http://www.modernsteel.com), to read more about 181 Fremont.





Courtesy of Gensler + HDR in association with luis vidal + architects

**ARCHITECTURALLY EXPOSED  
STRUCTURAL STEEL AWARD**  
AESS Buildings:  
Pittsburgh International  
Airport Terminal  
Modernization Program

Students must select a building that uses AESS and complete a write-up on the project.

**Winner: Taiseer Al-Salihi,  
The University of North Carolina  
at Charlotte**

The Terminal Modernization Program (TMP) is transforming Pittsburgh International Airport (PIT) into a modernized facility that enhances the passenger experience and supports the growth of airline traffic. Exposed structural steel plays a significant role in this transformation. The wavy ribbons of the terminal's lightweight, long-span roof are supported on tree-shaped columns, creating a forest-like sunshade within, while the openings between the roof's ribbons diffuse natural light into the terminal.



**603-402-3055 • Automated Layout Technology™**  
Visit [AUTOMATEDLAYOUT.COM](http://AUTOMATEDLAYOUT.COM) for a Quote

The first automated marking machine created specifically for the **layout of commercial handrails, stair stringers** and so much more utilizing your steel detailer's dxf files.

- Cut fabrication time by more than 50%
- Ensure the highest level of accuracy
- Boost your profit margins!
- Lay out complex geometry in seconds
- Designed to replace your existing fabrication table

*"It easily doubles our output – no mistakes"*  
**Plant Manager • Papp Iron Works**

*One current customer's team can layout 26 stair stringers in 58 minutes and ended up purchasing another machine for their second location.*

*"The guys love it. They jumped right in on it and have been working to make the most use of it. Great purchase."*  
**Nat Killpatrick • Basden Steel Corporation**

*"I think it's fair to say that this machine continues to exceed our expectations. We are very happy with it."*  
**Chief Operating Officer • Koenig Iron Works**

*"The machine is fantastic and could not be happier. Keep selling this machine, it's a winner."*  
**Misc. Shop Foreman • Koenig Iron Works**





**AISC BEST INTERVIEW AWARD**  
**HSS-to-HSS Moment**  
**Connections**

Students must conduct an interview with a professional in the steel industry and complete a project write-up.

**Winner: QiTong Han, Cooper Union**

HSS-to-HSS (hollow structural section) moment connections are defined as connections that consist of one or two branch members that are directly welded to a continuous chord that passes through the connection, with the branch or branches loaded by bending moment. Many research studies, like one performed by (former AISC intern) Matthew Fadden, currently a senior associate at WJE and a PhD student at the time, and his team members have helped to shape HSS information, requirements, and recommendations provided in the AISC *Specification for Structural Steel Buildings* (ANSI/AISC 360) and *Steel Construction Manual* (both available at [aisc.org/publications](http://aisc.org/publications)). Within the study, a reinforced connection used an HSS10×10×<sup>3</sup>/<sub>8</sub> column, an HSS12×8×<sup>3</sup>/<sub>8</sub> beam, and plates that were profiled to fit around the column face and sidewalls and were CJP (complete joint penetration) groove-welded to the face and sidewalls of the column. A quasi-static loading rate of 12.7 mm/min. (0.5 in./min.) was applied to simulate deformation imposed on a structure during an earthquake. The study demonstrated that external diaphragm plate reinforced HSS-to-HSS moment connections are capable of moving the location of inelasticity into the HSS beam member, making the desired beam plastic hinging. The results suggest that diaphragm plates can improve connection stiffness, and they are important to ensuring that the sources of inelastic rotation are limited to the beam and panel zone region. ■

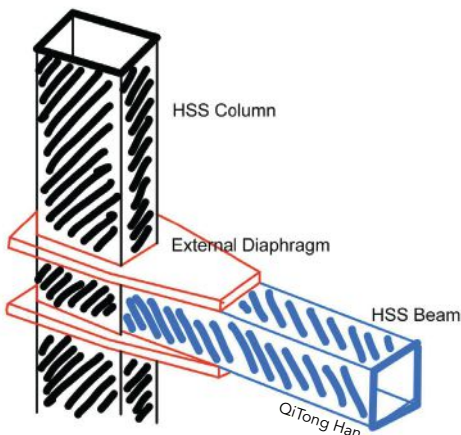

**When you can't be there...  
 see that the bolts are tight!**



1 800 552 1999  
 1 802 460 3100

**DuraSquirt® DTIs**  
 the best way to bolt!

info@appliedbolting.com  
[appliedbolting.com](http://appliedbolting.com)

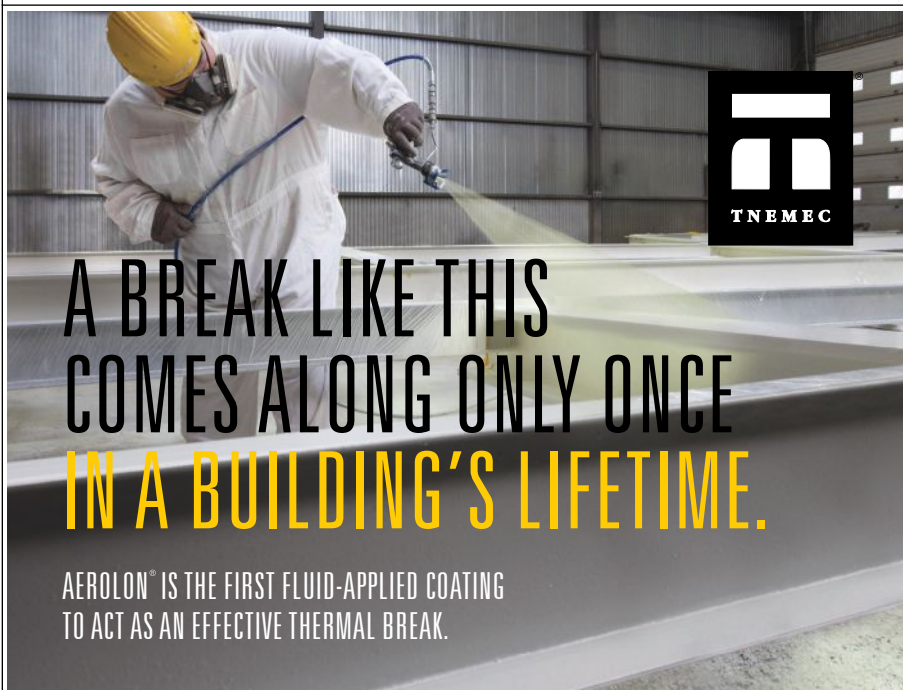

**A BREAK LIKE THIS  
 COMES ALONG ONLY ONCE  
 IN A BUILDING'S LIFETIME.**

AEROLON® IS THE FIRST FLUID-APPLIED COATING  
 TO ACT AS AN EFFECTIVE THERMAL BREAK.

A low VOC, water-based coating that can be easily spray-applied in the shop or in the field, Aerolon provides significant cost-saving advantages over structural thermal breaks, limiting design restrictions for architects and reducing application and labor time for contractors. **Find out more at [tnemec.com/thermalbreak](http://tnemec.com/thermalbreak).**



# Almost There

BY GEOFF WEISENBERGER

Despite taking place entirely online, SteelDay 2020 sees a big jump in participation from last year.



**Geoff Weisenberger**  
([weisenberger@aisc.org](mailto:weisenberger@aisc.org)) is senior editor of *Modern Steel Construction*.

**THIS YEAR'S STEELDAY** was a good news, bad news situation.

Bad news: In-person events were nonexistent. No “insider” thrill of going up a lift on the outside of an under-construction skyscraper. No shaking hands (or even bumping elbows) with a presenter after an engaging seminar. No being surrounded by the sights, sounds, and even smells of a functioning fabrication shop.

Good news: The all-online format allowed participants to engage in a safe, comfortable setting—and without the need to write their name on a “Hello. My name is...” sticker with a Sharpie. And they did it in large numbers. This year’s event saw a 42% attendance jump over last year, engaging more than 3,200 participants. In addition, AISC held a student photo contest and picked winners in three categories, as well as a judges’ favorite.

Read on for a quick rundown of events from across the country—all locally focused but with global accessibility—as well as a look at the winners of the photo competition. (Note: All referenced *Modern Steel Construction* articles can be found at [www.modernsteel.com](http://www.modernsteel.com).)

And remember: This all-virtual approach to SteelDay isn’t permanent. We’re looking forward to next year, when fabrication shops, job sites, and other facilities everywhere can open their doors to the public once again. More details will be posted at [aisc.org/steelday](http://aisc.org/steelday) in the coming months to help hosts and visitors plan for SteelDay 2021, which is set for September 24.

## Southern California

We’re stuck on the ground for now in real life, but the sky’s the limit in the virtual world—and the race was on for Southern California SteelDay attendees. Inspired by the *Amazing Race*, participants competed against fellow AEC professionals in Orange County, San Diego, and Long Beach in an around-the-world competition, solving clues, stopping in major global cities, and exploring some of the planet’s greatest steel landmarks.

## Cleveland

Cleveland participants were able to take a virtual cruise along a stretch of the Cuyahoga River in Cleveland spanned by many of the city’s iconic and historic bridges (and were encouraged to put a fan next to their computer to simulate a gentle river breeze). Attendees learned about several signature steel spans, including the 1901 Center Street Swing



Bridge, the 1917 Veterans Memorial Bridge, the 1927 Hope Memorial Bridge, the 2014 Columbus Road Lift Bridge, and the new I-90 Innerbelt Bridges.

Cleveland’s Hope Memorial Bridge.



Chicago's Willis Tower, whose base recently underwent a major renovation.



The Marvin Gaye Recreation Center in Washington, D.C.



Hoachlander Davis Photography

## Tennessee

Another virtual tour of multiple steel bridges, led by people who know them inside and out, took place in Tennessee.

- WSP's Rex Gilley discussed the design and construction of the recently completed I-440 bridge over I-65 in Nashville.
- Neel Schaffer's Henry Pate provided a behind-the-scenes look at what went into value engineering two bridges in east Tennessee.
- Carter Bearden and Evan Graves from HDR discussed the accelerated bridge construction (ABC) process that allowed crews to replace the Foster Avenue Bridge over the CSX Railroad in Nashville with only one month of anticipated closures.

## New York

New Yorkers reach higher and higher every day—especially those designing and building the supertall buildings that shape one of the world's most beloved and ever-changing skylines.

The New York event virtually brought together three AISC member structural steel fabricators who have worked on recent steel skyscraper projects in the Big Apple—Banker Steel, Owen Steel, and W&W/AFCO Steel—to provide helpful insights and advice. Among the projects discussed were 3 WTC, 7 Bryant Park (see “Park View” in the October 2015 issue), 425 Park Avenue (see the “Give Me Park Avenue” Structurally Sound column in December 2018), One Vanderbilt, and the New York Times Building (see “Inside Out” in the January 2009 issue). The panel also answered questions about current and upcoming projects in the New York metropolitan area—including tips for introducing the innovative SpeedCore system ([aisc.org/speedcore](http://aisc.org/speedcore)) to New York.

## Chicago

A new base has added 300,000 sq. ft of multiuse space and new entryways to Chicago's Willis Tower, the tallest building west of Manhattan. SteelDay attendees were able to learn about the design and construction team's approach to such a massive challenge during a virtual event. To read about the project, see “A Steel ‘Base-lift’” in the September 2020 issue.

## Boston

The steel industry is on the cusp of reinventing itself to deliver projects faster and with less waste. A recent example of this is the emergence of tighter data exchanges between engineers and fabricators for steel frame projects. A Boston-focused virtual workshop—which included a panel of engineers, fabricators, and erectors—compared the pros and cons of delivering steel projects using traditional methods as well as new “integrated” methods, and discussed why individual owners and contractors prefer one method over another.

## Western U.S.

The American West is full of noteworthy steel bridges, and this virtual event highlighted two of them. David Konz with Atkins discussed the 2020 Prize Bridge Award-winning Manning Crevice Bridge in Riggins, Idaho (see “Narrow Margin” in the October 2018 issue), which is noteworthy both for its striking asymmetrical design and for successfully navigating challenging environmental restrictions during erection. From Idaho, the presentation jumped to Washington's newly reconstructed BNSF Wind River Bridge in Skamania County—another 2020 Prize Bridge Award winner (see all of the 2020 winners in the July 2020 issue). Alan Bloomquist with BNSF Railway revealed how the team tackled the challenge of minimizing track outages while replacing an old bridge with a new steel bridge that boasts an expected 100-year service life. The event concluded with an “Ask the Fabricator” panel discussion in which Jeff Kovar with Vigor and Clark Olsen with Utah Pacific Bridge & Steel (both NSBA member fabricators) fielded questions.

## Florida

Considering the soaring ambitions of the students who gather within its walls, it's only appropriate that the new Mori Hosseini Student Union at Embry-Riddle Aeronautical University in Daytona Beach, Fla. (see “Winging It” in the November 2019 issue), looks like it's about to take to the skies. And it's no surprise that the building won a 2020 AISC IDEAS<sup>2</sup> Award. Joe Tattoni of ikon.5 architects, the design architect for the project, discussed the project in a conversation streamed live on YouTube.

## Washington, D.C.

People from across the country tuned in to learn about D.C.'s new Marvin Gaye Recreation Center, a 2020 AISC IDEAS<sup>2</sup> winner (see all of this year's winners in the May 2020 issue) as well as the recipient of multiple sustainability awards. Beloved by the community it calls home—and where the iconic singer for which it is named grew up—the facility is a resiliency success story not just in terms of the built environment but also the people it hosts.

## Trivial Pursuit

Several locally focused virtual trivia events took place from coast to coast, pitting participants against one another in friendly online competition. Events were held in North Carolina, Philadelphia, Los Angeles (with a '70s theme), Denver (this event was inspired by Wheel of Fortune), Atlanta, San Francisco, Seattle, Dallas, and Houston.



## Student Photos

AISC hosted a photo contest exclusively for students in conjunction with SteelDay. Students were challenged with submitting their best original photos that capture the beauty of American structural steel, for consideration in one of several categories. A panel of AISC judges evaluated the entries based on quality, creativity, and originality. One lucky winner in each category was awarded a prize, as well as the opportunity to have their photo published in *Modern Steel Construction*. Here are the winners. ■

right: "Steel Bridges at Sunset"  
BNSF Bridge 58.8 Replacement in transit, Carson, Wash. (Columbia River)  
Student: Kristian Hellberg, Oregon State University

below: "Steeling the Spotlight"  
Steel, Providing Height + Light,  
Lyon, France  
Student: Emma Sweeten, Virginia Tech

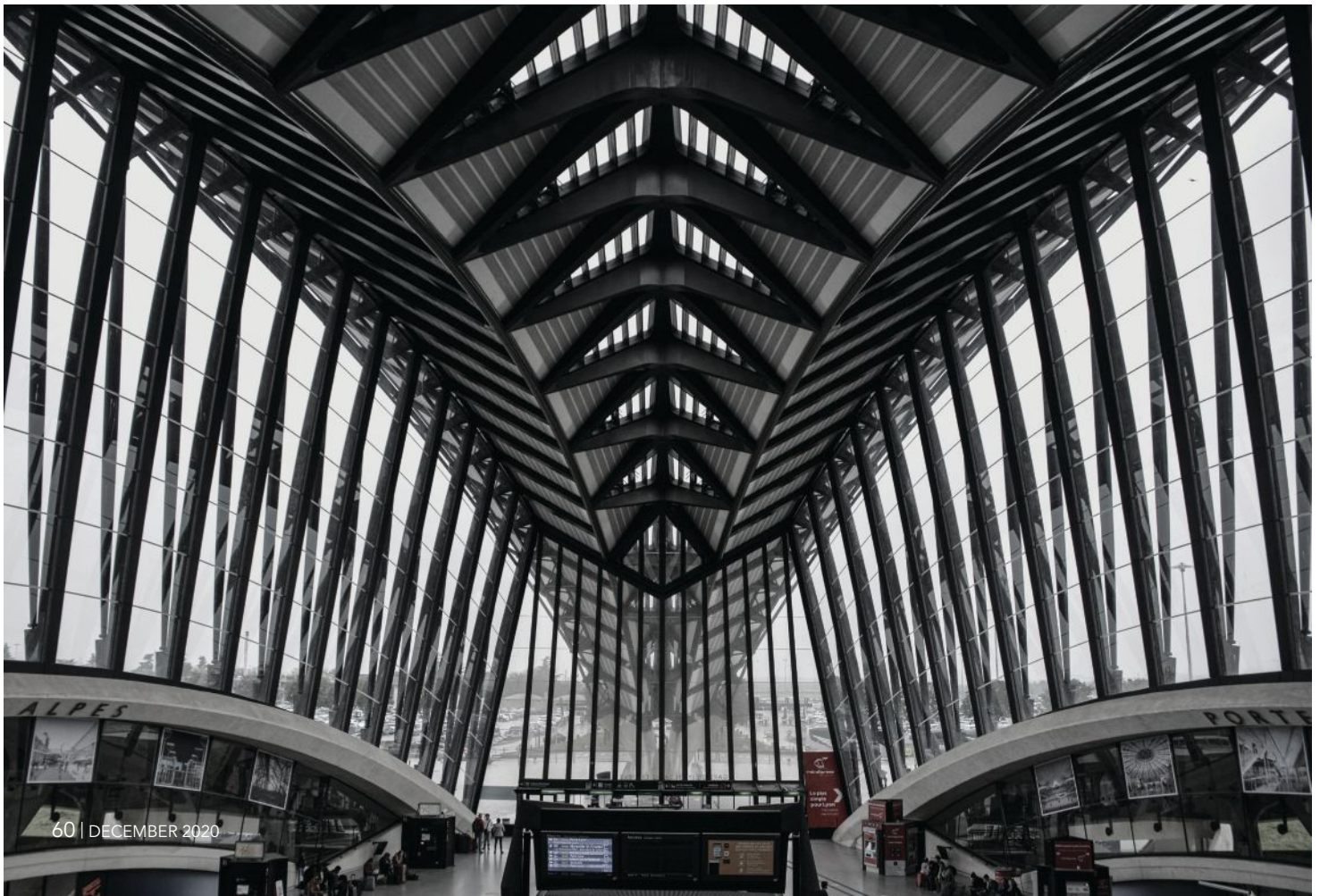
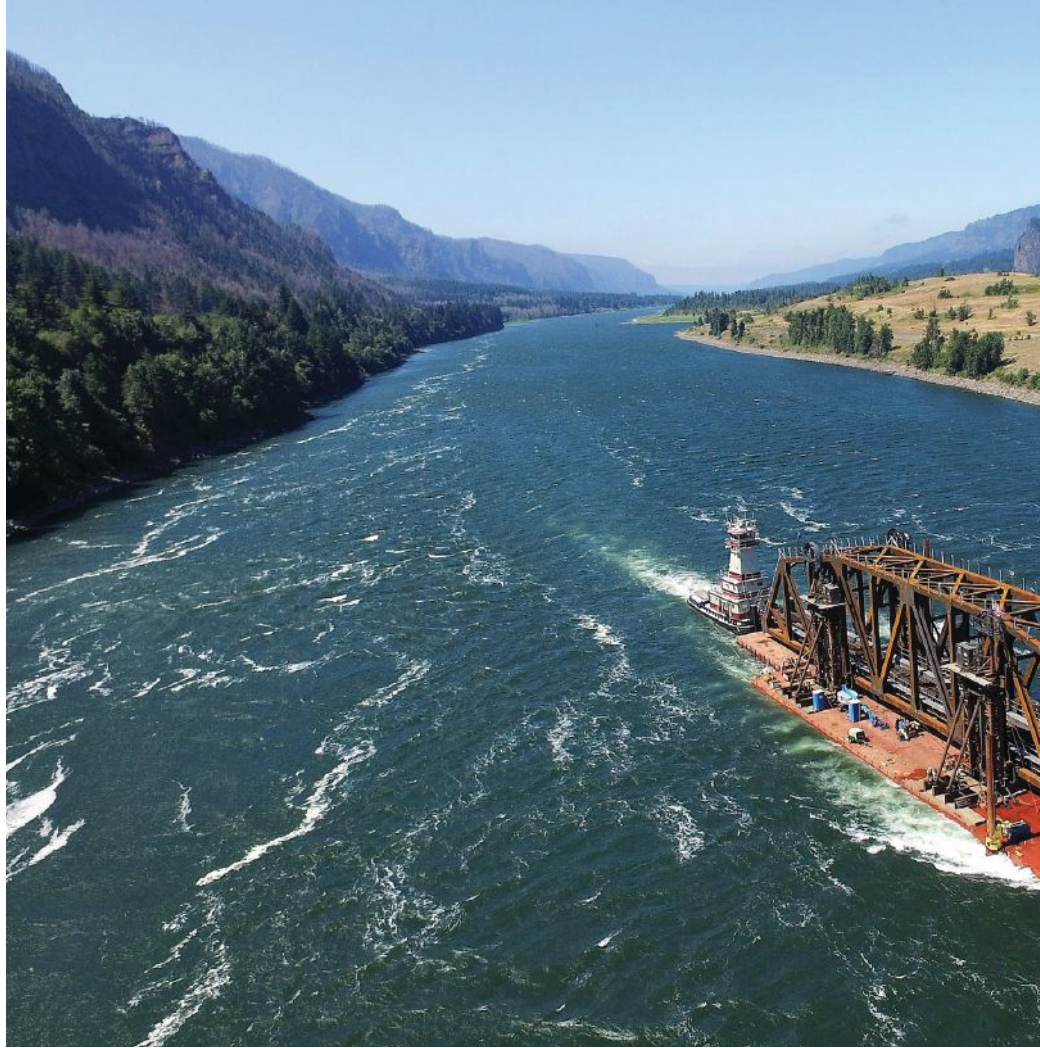





**OH SNAP!** Student SteelDay Photo Contest



right: "Judges' Favorite"  
Flamboyán, Ponce, Puerto Rico  
Student: Glorimar Cabán, University of Puerto Rico at Mayagüez

below: "Details and Close-Ups"  
Steel Bridge and Nature, Ponce, Puerto Rico  
Student: Adrian D. Colon Ortiz, University of Puerto Rico at Mayagüez





## HIGGINS AWARD

### SpeedCore Researcher Amit Varma Wins Higgins Lectureship Award



AISC has awarded its 2021 T.R. Higgins Lectureship Award to Amit H. Varma, Karl H. Kettelhut Professor of Civil Engineering and Director of the Bowen Laboratory of Large-Scale CE Research at Purdue University's Lyles School of Civil Engineering.

Varma will present "SpeedCore and Steel-Concrete Composite Construction: The Best of Both Worlds" as a keynote speaker during NASCC: The Steel Conference, which will take place April 14–16, 2021, in Louisville. Varma will share what he's learned from more than 12 years of researching composite steel-concrete construction, highlighting experimental behavior, numerical modeling, and design of composite walls and the SpeedCore system for wind loading, seismic loading, and fire loading conditions.

Varma also presented a keynote on the future of high-rise building construction and the potential impact of 3D printing, robotics, and advanced manufacturing methods at AISC's Flash Steel Conference, which took place online in late October (see [aisc.org/flash](https://aisc.org/flash)).

"I first met Amit when AISC awarded him our first Milek Fellowship in 2004," said AISC's vice president of engineering and research, Lawrence F. Kruth, PE. "Since then, he has become a world-renowned researcher in steel and fire. AISC is proud to recognize Amit for his outstanding research accomplishments. I look forward to hearing his keynote at the Steel Conference in April."

The \$15,000 T.R. Higgins Lectureship Award recognizes an innovative lecturer or author whose outstanding technical writing constitutes a ground-breaking addition to engineering literature on fabricated structural steel. For more about the T.R. Higgins Lectureship Award and its past winners, please visit [aisc.org/higgins](https://aisc.org/higgins).

Varma has dedicated his academic and professional life to the development of innovative steel-concrete composite structures for the built infrastructure, including commercial, industrial, and safety-related nuclear structures. He has conducted fundamental research leading to the development of design provisions for composite members, connections, and overall structural systems subjected to extreme loading conditions, including seismic, fire, blast, and impactive loading.

"Amit's research on SpeedCore is a game-changer for our industry," said Kruth. "His research includes not only the seismic resistance of SpeedCore but also performance-based fire engineering; his research has demonstrated that no additional fireproofing is required for SpeedCore."

Varma received his BS in Civil Engineering from IIT-Bombay, an MS from the University of Oklahoma, and a PhD from Lehigh University. He has been an academic for 20 years and at Purdue University for 16 years. His research products are the basis of (and directly cited in) several AISC specifications (AISC 360, AISC 341, AISC N690) for the design of steel-concrete composite structures for building structures and safety-related nuclear facilities. He has previously received the AISC Milek Faculty Fellowship Award (2004), AISC Special Achievement Award (2017, 2020), and the ASCE Shortridge Hardesty Award (2019). In addition, Varma is the Chair of AISI/AISC Task Committee 8 on Fire Design and a member of Task Committee 5 on Composite Design. He is also a member of the AISC Committee of Specifications and ASCE/SEI 7 Standard Committee.

## People & Companies

**CSD Structural Engineers** announced the appointment of **John Rolfes, SE, PE**, to the newly created position of technical director. Rolfes joined CSD in 1987, working primarily on the design of heavy industrial projects, including steel mills, heavy manufacturing facilities, and automotive plants. He has designed and managed large connection design projects for major fabricators and has worked with steel erectors providing construction engineering services nationally. He specializes in seismic analysis and design as well as industrial buildings.

**STV Group's** Board of Directors has named **Gregory A. Kelly, PE**, president and CEO. In this role, Kelly will be responsible for guiding the firm toward achieving its short- and long-term strategic goals with an emphasis on performance, business development, technology, and human capital. Kelly will be based in New York.

**Ruby+Associates** announced its national certification as a **Women's Business Enterprise** by the **Great Lakes Women's Business Council**, a regional certifying partner of the **Women's Business Enterprise National Council**.

**Trimble** announced the winners of its **Tekla Global Building Information Modeling (BIM) Awards**. The winner for the Best Developer Project, **Bolt Clearance Check**, is a **Tekla Structures** application checking if there is enough space to assemble bolts. The application, developed in just 15 hours by AISC member detailer **JMT Consultants**, shows how quickly new tools can be created using an easy programming interface.



## MEMBERSHIP

### AISC Board Approves New Full and Associate Members



Full

Acadian Contractors, Inc., Abbeville, La.  
Accelerated Construction and Metal,  
Modesto, Calif.  
Advance Industrial Mfg, Inc.,  
Grove City, Ohio  
AF Steel Fabricators, Phoenix  
Alumiworks, Inc., Randleman, N.C.  
Barone Steel Fabricators, Brooklyn, N.Y.  
Covington Machine and Welding, Inc.,  
Annapolis, Md.  
Dakota Precision Fabricating, Inc.,  
Forman, N.D.  
Extreme Precision Industrial Contractors,  
Gillette, Wv.  
Gerlinger Steel and Supply,  
Woodland, Calif.  
RHRBD Holdings, LLC dba Hale Steel,  
Alexander, Ark.

Nick's Welding and Fabricating, Inc.,  
Hixton, Wis.  
Paradise Architectural Panels and Steel,  
Miami, Fla.  
Pegasus Steel, Goose Creek, S.C.  
Perfect Group, LLC, Lumberton, Miss.  
Premier Fabrication, LLC, Congerville, Ill.  
Richards Welding and Metal Fabrication,  
LLC, Wendell, N.C.  
Tippen Steel Services, Boyd, Texas  
Triple S Welding Company, Lytle, Texas  
Twin Brothers Marine, LLC, Louisa, La.  
Victory Machine and Fabrication, LLC,  
Sidney, Ohio  
RWT Corporation, dba Welding Works,  
Madison, Conn.  
Wilson Iron Works, Crown Point, Ind.  
Worth Steel, LLC, Pocatello, Idaho



Associate

#### Erectors

Alliance Riggers and Constructors, Ltd.,  
El Paso, Texas  
Misco Steel Erectors, Inc.,  
West Terre Haute, Ind.  
Rogue Erectors, LLC, Leander, Texas

#### Detailers

Ayari Venture, Greensboro, N.C.  
E2G Detailing Services, LLC,  
Woonsocket, R.I.  
Fab Design Engineers, Bangalore, INDIA  
JPW Engineering Services Pvt., Ltd.,  
Nashik, Maharashtra, INDIA  
Mid-Atlantic Structural Detailing,  
Myersville, Md.  
PT Sambada Gaty Praya, Ciangrana,  
Bogor, INDONESIA

## AWARDS

### ASE Gift Establishes AISC Terry Peshia Early Career Faculty Awards

Thanks to a generous donation from the Associated Steel Erectors of Chicago, AISC's award for outstanding young educators is now dedicated to a remarkable man.

The Terry Peshia Early Career Faculty Awards are named in honor of the late Terry Peshia, chairman and CEO of AISC member fabricator Garbe Iron Works, Inc., in Aurora, Ill. The awards, which recognize tenure-track faculty who demonstrate exceptional promise in the areas of structural steel research, teaching, and other contributions to the structural steel industry, will now come with a \$2,500 honorarium.

"Terry spent his career promoting and contributing to the steel industry locally as well as nationally," said ASE President Timothy Harkins. "For all those years of service, the Associated Steel Erectors of Chicago is in his debt, and we are pleased to honor his memory in this way."

Peshia was very involved with ASE activities and served as Chair of the AISC Board of Directors. Many of his leadership traits also characterize great educators, which is why the new Terry Peshia Early Career Faculty Awards are such a fitting tribute.

"Terry's influence and impact on the steel industry cannot be overstated," said AISC president Charles J. Carter, SE, PE, PhD. "A master of appropriate, helpful criticism, he also was your strongest supporter as you adapted to resolve it. His vision was always of what could be. His talent was orchestrating it to happen."

The winners of the 2021 Terry Peshia Early Career Faculty Awards will be announced early next year. For more information about AISC's educator awards, please visit [aisc.org/education/university-programs/educator-awards](https://aisc.org/education/university-programs/educator-awards).

## PUBLIC REVIEW

### Structural Stainless Steel Code of Standard Practice Available for Public Review

The new AISC *Code of Standard Practice for Structural Stainless Steel Buildings* (AISC 313) is available for public review until December 11, 2020.

You can download the draft standard and a review form from [aisc.org/publicreview](https://aisc.org/publicreview). Hard copies are also available (for a \$35 charge) by calling 312.670.5411. Please submit comments, using the online forms,

to Cynthia J. Duncan, AISC's director of engineering ([duncan@aisc.org](mailto:duncan@aisc.org)), by December 11 for consideration. This new standard is expected to be completed and available in late 2021.



## Letters to the Editor

### A Cautionary Tale

The Figure 5 detail in the April 2020 SteelWise (“Delegating Connection Design,” [www.modernsteel.com](http://www.modernsteel.com)) is almost the exact detail that caused the failure of the Hyatt Hotel in Kansas City decades ago. Unless someone has done a design test I am unaware of, the channels should always be back-to-back instead of toe-to-toe, as shown in the figure.

*Michael Buckner*

**Response from author Clifford Schwinger, PE, vice president and quality assurance manager with the Harman Group:**

Not only is the connection you referred to similar to the Kansas City Hyatt Regency hanger connection, it actually *is* the (revised) Hyatt Regency hanger connection detail. I remember the night that happened as if it were yesterday. I was watching TV, and they broke into the network broadcast to go to a live feed of the disaster. I soon realized that they were talking about a structural collapse. As a young structural engineer, it hit home. And in the 39 years since that tragedy, not a week goes by that I don’t think about it. It is the structural engineering equivalent of

the “North Star” cautioning me as to how fast things can go wrong when we structural engineers let our guard down.

This flawed connection detail is the poster child for everything that can go wrong with a connection. Through perspective provided by 39 years of hindsight (and multiple readings of “The Chronology and Context of the Hyatt Regency Collapse” by Gregory P. Luth, which appeared in the May 2000 ASCE *Journal of Performance of Constructed Facilities*), I often ponder how this tragedy could have happened—and I wonder if a similar connection failure could happen again.

The trouble appears to have started out as a drafting error (a beam reaction imposed on the hanger was inadvertently left off a detail). But it was also a failure by the EOR to develop a reasonable concept connection detail (to clearly illustrate the EOR’s required design intent to the fabricator). It was a failure (by everyone) to consider secondary stresses in the connection (i.e., it was a “kinked connection”) and it was a failure by the EOR to consider constructability issues. It was a communication failure (miscommunication between

the EOR and the fabricator’s connection design engineer regarding who would do the actual final connection design). It was *not* a connection design failure—because no one ever designed the connection! There also seems to have been a failure to perform a diligent and comprehensive quality assurance review during design—although such a review was later performed after a partial failure occurred in another section of the structure during construction. The flaws in the hanger connection were not discovered during that review. Significant clarity has been added to the AISC *Code of Standard Practice for Steel Buildings and Bridges* (ANSI/AISC 303) since 1981. These improvements have hopefully reduced the chances of such a tragedy happening again. The latest version, AISC 303-16 has greatly clarified everyone’s duties and responsibilities regarding connection design—in particular, the responsibilities of the EOR and the fabricator’s licensed connection design engineer. In the end, the EOR is the party ultimately responsible for ensuring the safe design of building structures, including all connections, even when delegating connection design.

### Yes, You Can!

The August “Lifetime Advocate” Field Notes column on Hollie Noveltsky was a nice read ([modernsteel.com/podcasts](http://modernsteel.com/podcasts))! I have three daughters that I’d love to get into this business. Done right, you can make

a pretty good living at it. They always tell me it’s not a place for a woman to run, and I bring up Hollie. Now I can prove to them that I’m not just making it up!

As Hollie mentioned her dad, his advice sounded just like my dad’s: plain

old common sense in making decisions on a day-to-day basis.

Thanks for an article that I can give my girls to read and prove that yes, they can do it!

*Brian R. Jackson, Bradford Steel  
East Freetown, Mass.*

## advertiser index

AISC	8   13   15	CoreBrace LLC	47	QuickFrames USA	53
Applied Bolting	57	FICEP	11	SDS/2	7
Automated Layout Technologies	56	Infra-Metals	67	SidePlate	42
Bend-Tech	14	LNA Solutions	12	St. Louis Screw & Bolt	53
Bull Moose Industries	back cover	MDX Software	47	Tnemec Company	57
Chicago Metal Rolled Products	insert	Nucor Vulcraft	3	Trimble	5
Controlled Automation	43	Peddinghaus Corporation	2	Voortman Corporation	52





## SMITH-EMERY

Inspection • Testing • Metallurgy

Assuring Structure & Life Safety Since 1904

### Non-Destructive Testing

- PAUT
- Visual (CWI, CWB, CSWIP)
- MT
- UT

### Owner QA

- Fabrication Oversight
- Specification Review
- Field Inspections
- WPS Reviews

### Metallurgical Laboratory

- Environmental Laboratory
- Firestop Inspection

### Supplier Audits

- IAS
- IAPMO
- City of Los Angeles
- Clark County, NV

### Contractor QC

- Fabrication Shop NDT, CWI
- Vendor Audits
- QMS Development
- WPS and PQR Testing

### Curtain Wall Performance Testing

- Concrete Testing
- Chemical Laboratory

1.833.405.0536

steel@smithemery.com

www.smithemery.com



## Structural Engineers

Are you looking for a new and exciting opportunity?

We are a niche recruiter that specializes in matching great structural engineers with unique opportunities that will help you utilize your talents and achieve your goals.

- We are structural engineers by background and enjoy helping other structural engineers find their "Dream Jobs."
- We have over 30 years of experience working with structural engineers.
- We will save you time in your job search and provide additional information and help during the process of finding a new job.
- For Current Openings, please visit our website and select Hot Jobs.
- Please call or email Brian Quinn, PE: 616.546.9420 | [Brian.Quinn@FindYourEngineer.com](mailto:Brian.Quinn@FindYourEngineer.com) so we can learn more about your goals and interests. *All inquiries are kept confidential.*

SE Impact by SE Solutions, LLC | [www.FindYourEngineer.com](http://www.FindYourEngineer.com)

## Major Online Auction Featuring Late Model Ficep Structural Steel Machines

**2015 Ficep K100 Band Saw Line**, 40"x17.7" @ 90 Deg., 24.4x17.7" @45 Deg., 196 - 558 FPM Band Blade Speed, 12 HP Motor, 20 mt - 65' Long Bar In-Feed, 20mt - 65' Out-Feed, Mfg. Date: 2015

**2015 FICEP 1202 DDRC CNC Drill & FRC Thermal Coping Line**, 48"x24" Max. Beam, 65' Carriage In-Feed, 20 mt Long Bars, 65' Out-Feed, Transfers, (2) Drill Heads W/Tool Changers, FRC (4) Sided Coper with HPR260XD Plasma, Mfg. Date: 2015

**2004 Ficep 1003 DZB Drill & Ficep SGB 1045 Saw Line**, 40"x18" Max. Beam, (3) Spindle W/Tool Changer, Marking Unit, 90' Carriage In-Feed/155' Out-Feed, SGB1045 Miter Saw, (18) Transfers, Mfg. Date 2004, New Drives, Motors and CNC Upgrade 2015

**2004 Ficep Thermal Coping Line**, 48"x24" Max. Beam/Channels, 65' Carriage In-Feed, 100' Out-Feed, HT2000 Plasma, Dust Collector, Mfg. Date: 2004, New Drives, Motors, and CNC Upgrade 2015

**Fork Trucks**, 10,000# Combi-Lift, 17300# Combi-Left, 7,000# Hyster, 6,000# Nissan, Ottawa Yard Jockey

**Welders**, Approx. 36 welders, Lincoln Flextec 500's, 455's, DC655's, DC600's, Miller Summit Arc 1000's, Sub-Arc Welding System,

**Bridge Cranes**, (5) 5 Ton x 48' Span Single Girder Top Running, Radio Ctrl., 5 Ton x 48' Span Double Leg Gantry and Spanco Crane System with (11) 500# hoists

**2016 Zeiss Contura G2 Model 10/12/6 Coordinate Measuring Machine**

2003 Akira Seiki V-4AVMC, Vehicles, Acorn Welding Tables, Hand Tools, YMZ Radial Drill, Advanced Sweeper Captor 4800, Hand Tools & Clamps, Robot, Brake Dies, Water Buffalo 500 Gallon Tank, Hardness Tester, Flammable Storage Cabinets, Portable Storage Offices, Do-All Band Saw Model C4100 NC, Steel Inventory, Much More

**Complete Facility Closure, Surplus to the Ongoing Operations of ConXtech, Inc.**

24493 Clawwater Road, Hayward CA 94545

Auction Being Conducted by

The Branford Group in Conjunction with Prestige Auctions

Auction Ends Wednesday December 9th, 2020

Inspection Dates, December 7th & 8th

[frank@prestigeequipment.com](mailto:frank@prestigeequipment.com) | 631.249.5566

[aduncan@thebranfordgroup.com](mailto:aduncan@thebranfordgroup.com) | 203.488.7020

## LATE MODEL STRUCTURAL STEEL MACHINES AVAILABLE IMMEDIATELY

**Peddinghaus HSFD 2500/C Plate Processor**, 4" Max. Plate, 96" Max. Width, 48 HP Drill, Tooling, 2017, #30956

**Peddinghaus FPB-1800/3**, Punch Plasma Plate Fabricator, 70 T Punch, 72" Max. Plate Width, HPR260XD, Siemens CNC, 2013, #30727

**Peddinghaus PCD1100/3B**, 40" Beam Drill With ABCM 1250/3D Coper, 60' In/Out Conveyor & Transfers, 2013, #30825

**Peddinghaus AFPS 623M Anglemaster**, 6" x 6" x 1/2" Punch & Shear Line, PC Touch Screen CNC, 250 Ton Shear, 2002, #30723

**Peddinghaus AFCPS 823A Anglemaster**, 8" x 8" x 3/4" Punch & Shear Line, PC Touch Screen CNC, 400 Ton Shear, 1997, #31083

**Peddinghaus Ocean Liberator SACM-1250/A**, 5-Axis Oxy Fuel Cutting & Coping, 44" x 24" Max. Profile, 2016, #30821



We are actively looking for used Structural Steel Equipment, Contact [claire@prestigeequipment.com](mailto:claire@prestigeequipment.com)

[www.PrestigeEquipment.com](http://www.PrestigeEquipment.com) | (631) 249-5566

Connect with AISC on Social Media



[facebook.com/AISCdotORG](https://facebook.com/AISCdotORG)



@AISC



[youtube.com/AISCSteelTV](https://youtube.com/AISCSteelTV)



@AISC

## Structural Steel Estimator/Salesman

Gipson Steel is a family owned company located in Meridian, MS that has been in the structural steel fabrication business since 1976. We are searching for a structural steel estimator/salesman with at least 5 years of experience who has the ability to read and interpret structural drawings. This person must be able to handle all aspects of the bidding process: material take off, estimating labor, gathering prices, submitting bids and negotiating with customers to finalize contracts.

Send resume to: [Resumeg@comcast.net](mailto:Resumeg@comcast.net)



# structurally sound



Terri Meyer Boake

## MORE THAN MEETS THE EYE

---

**WHILE VIEWING DISTANCE** is often the primary driver when it comes to selecting which AESS (architecturally exposed structural steel) level(s) to specify, the situation can sometimes be a bit more complex—but it doesn't have to be complicated.

For example, at the Caltrans District 7 Headquarters in Los Angeles, a fine aluminum screen covers the exposed galvanized steel frame, providing shading for a façade that is shaped like an oversized street number to provide iconic signage for the building. And because of this complex, multi-tiered design, connections that might typically be designated as AESS 3: Feature Elements in Close View only need to be designated as AESS 2: Feature Elements not in Close View. (For more information on the various AESS levels, see “Maximum Exposure” in the November 2017 issue, available at [www.modernsteel.com](http://www.modernsteel.com).)

Want to learn more about complex AESS scenarios? See Terri Meyer Boake's article “Complexity, Simplified” in next month's issue, which will feature information excerpted from her new book, *Complex Steel Structures: Non-orthogonal Geometries in Building with Steel*. ■



# Seasons Greetings

**INFRA-METALS**

[www.infra-metals.com](http://www.infra-metals.com)

**DELTA STEEL, INC.**

[www.deltasteel.com](http://www.deltasteel.com)

Consider us your partner,  
not just another supplier.

**Largest Selection of Structural Inventory  
Comprehensive First-Stage Processing  
Industry Leading Customer Service**



**With many locations to serve you:**

Wallingford, CT  
Langhorne, PA  
Petersburg, VA  
Atlanta, GA  
Tampa, FL  
Hallandale, FL  
Marseilles, IL  
New Boston, OH

Houston, TX  
San Antonio, TX  
Cedar Hill, TX  
Fort Worth, TX  
Chicago Heights, IL



**Full Member**



# HOLLOW STRUCTURAL STEEL TUBE FROM BULL MOOSE

**BUILD A  
LANDMARK.**



For projects that will stand the test of time, start with Bull Moose HSS tube.

Our direct-form manufacturing process enables us to use the highest grade HSLA steel...and form it directly into a tube.

With sizes ranging from 1.5" square to 18"x6", and wall thicknesses from 1/8" through 5/8", Bull Moose features one of the largest size ranges of HSS products in the industry.

*For strength, versatility and reliability, build with Bull Moose.*

## BULL MOOSE ADVANTAGES

- Strength ranges of 46 KSI to 110 KSI
- Tighter tolerances, sharper edges, and straighter tubes
- Widest variety of custom sizes/lengths, including metric
- In-line NDT weld testing available on all tube
- Readily available weathering grade steel
- Fast delivery with 8 domestic sites



**BULL MOOSE**  
For exceptional strength.

1819 Clarkson Rd.  
Chesterfield, MO 63017

**800.325.4467** | **BULLMOOSETUBE.COM**