

Modern Steel Construction

May 2020

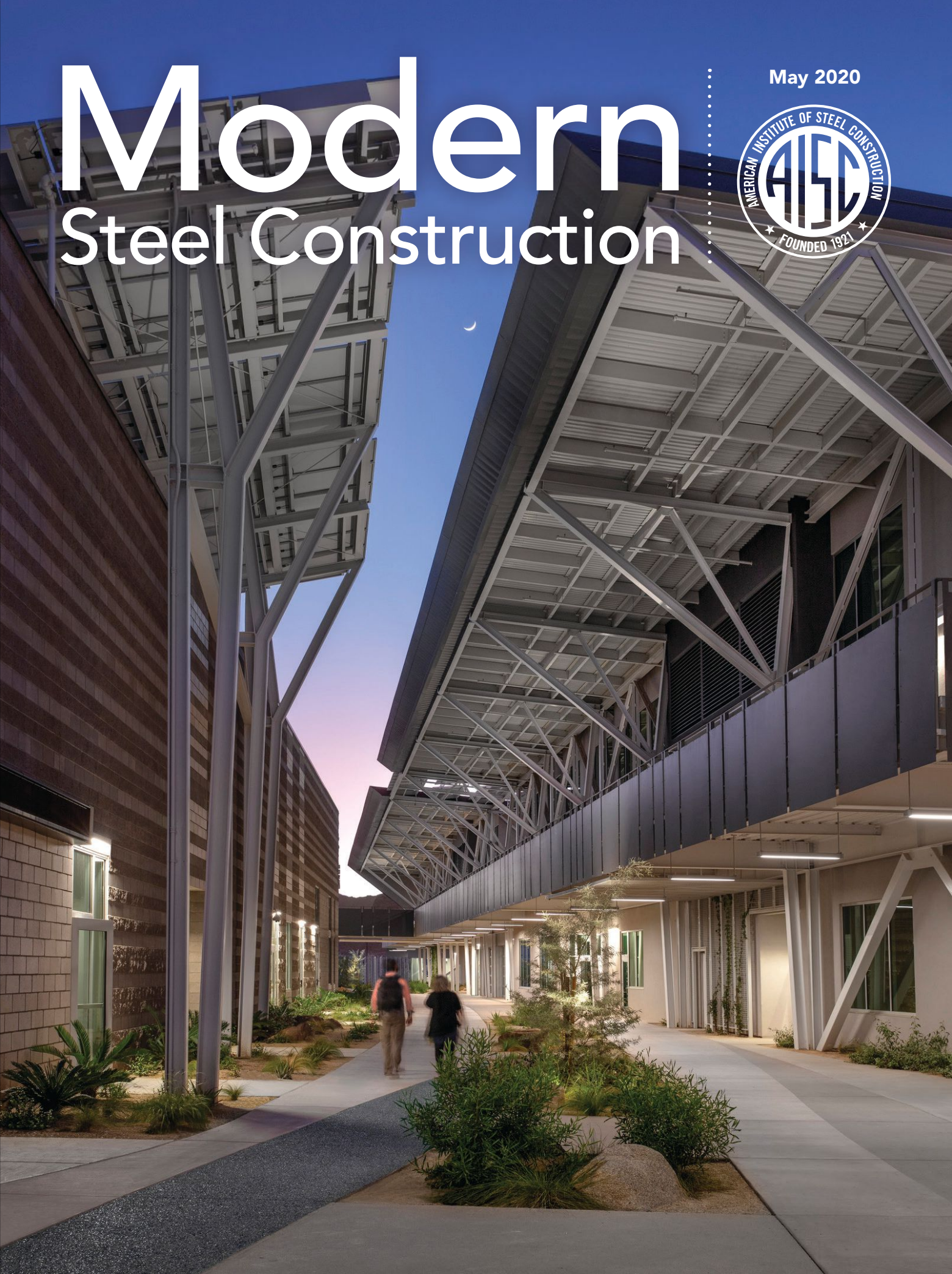

NORTHWEST STEEL FAB, INC.

FROM PEDDIASSEMBLER TO PROFIT

CHET FRIZZELL
Vice President

JOSHUA JAMES
Project Manager

ANDY JAMES
President

The most impressive aspect of the Peddiassembler is the quality of the weld and the speed of the assembly. It gives us the opportunity to fit beams, put them in a stack and give them to the welders. We are able to continue preassembling beams that are right on the number and the welders love that.

-JOSHUA JAMES

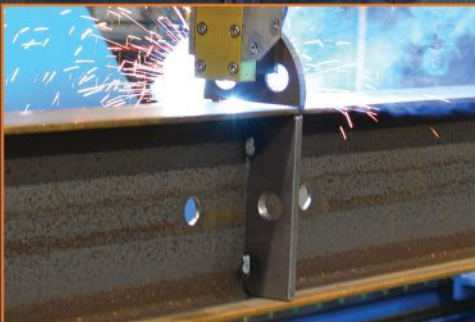

THE
PEDDIASSEMBLER

Peddinghaus

STRONGER THAN
STEEL®

www.peddinghaus.com | info@peddinghaus.com | (815) 937-3800

CALLING ALL INNOVATORS!

If you recently worked on an amazing project that featured structural steel, we want to hear from you. Submit it for a 2021 IDEAS² award!

Entries close on SteelDay, September 25, 2020.

.....
enter now at aisc.org/ideas2



2020 IDEAS² National Award
**Mori Hosseini Student Union—
Embry-Riddle Aeronautical University,**
Daytona Beach, Fla.
Photo: Brad Feinknopf



2021
**IDEAS²
AWARDS**

Innovative Design in Engineering and
Architecture with Structural Steel

Modern Steel Construction

May 2020

in every issue

departments

- 6 EDITOR'S NOTE
- 9 STEEL INTERCHANGE
- 12 STEEL QUIZ
- 62 NEWS & EVENTS
- 66 STRUCTURALLY SOUND

resources

- 65 ADVERTISER INDEX
- 65 MARKETPLACE & EMPLOYMENT

features

- 28 2020 IDEAS² Awards**
All about the great ideas that became the winning projects in this year's IDEAS² Awards competition.
- 48 Upscale and Urbane**
BY LEA COSENZA AND ALBERT MEYER, PE
Steel provides efficiency at all levels of a new hotel in the center of the City of Brotherly Love.
- 54 California Dreaming**
INTERVIEW BY GEOFF WEISENBERGER
A northern fabricator discusses the challenges and solutions of fabricating an aquarium addition in a SoCal locale.
- 58 Tub Time**
BY KARL E. BARTH, PhD, GREGORY K. MICHAELSON, PhD, ROBERT M. TENNANT, AND ADAM D. ROH
A new report showcases the development of economical and efficient shallow press brake-formed tub girder bridges.

columns

steelwise

- 16 Sound Control**
BY ROBERT CONNICK
Tips on designing for sound isolation and noise control in steel buildings.

field notes

- 20 Judge and Jury**
INTERVIEW BY GEOFF WEISENBERGER
John Parucki weighs in on 25 years as head judge of AISC's Student Steel Bridge Competition.

business issues

- 22 Smile, You're on Camera!**
BY ANNE SCARLETT
Video meetings have abruptly evolved from as-needed to must-use for many businesses. Here are some best practices for making the most of them.



ON THE COVER: A steel canyon bisects Canyon View High School in suburban Phoenix, one of this year's IDEAS² Award winners, p. 28.
Photo: Bill Timmerman.

MODERN STEEL CONSTRUCTION (Volume 60, Number 5) ISSN (print) 0026-8445; ISSN (online) 1945-0737. Published monthly by the American Institute of Steel Construction (AISC), 130 E Randolph Street, Suite 2000, Chicago, IL 60601. Subscriptions: Within the U.S.—single issues \$6.00; 1 year, \$44. Outside the U.S. (Canada and Mexico)—single issues \$9.00; 1 year \$88. Periodicals postage paid at Chicago, IL and at additional mailing offices. Postmaster: Please send address changes to MODERN STEEL CONSTRUCTION, 130 E Randolph Street, Suite 2000, Chicago, IL 60601.

DISCLAIMER: AISC does not approve, disapprove, or guarantee the validity or accuracy of any data, claim, or opinion appearing under a byline or obtained or quoted from an acknowledged source. Opinions are those of the writers and AISC is not responsible for any statement made or opinions expressed in MODERN STEEL CONSTRUCTION. All rights reserved. Materials may not be reproduced without written permission, except for noncommercial educational purposes where fewer than 25 photocopies are being reproduced. The AISC and Modern Steel logos are registered trademarks of AISC.



Printed on paper made from a minimum of 10% recycled content.

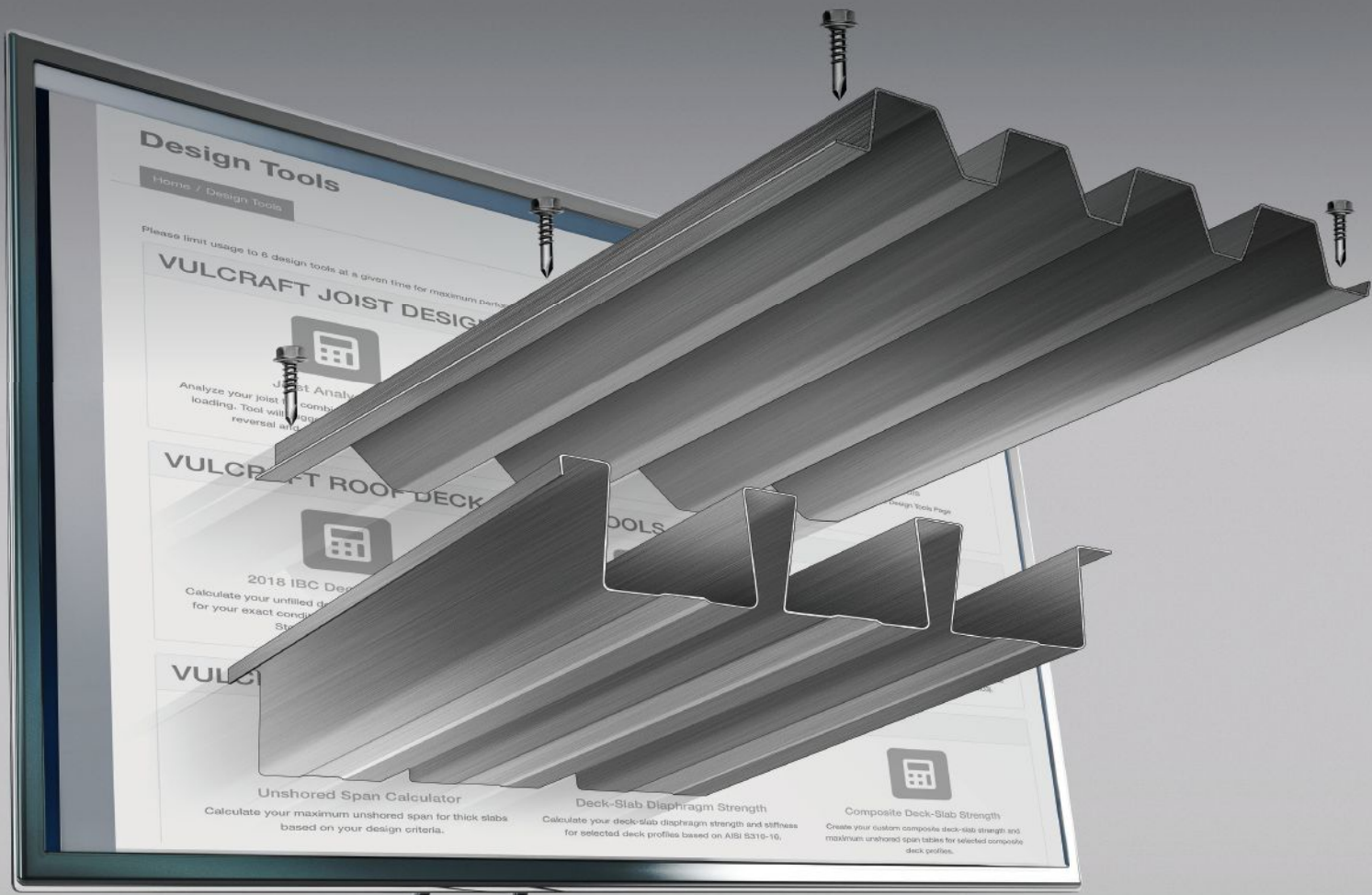

Our Online Design Tools are Always Open

We make steel deck design easy, fast and tailored to your specific project with our online design tools. Easily access all the design data and product specs you need to create the most efficient and effective design for your structure. No cryptic language. No red tape to jump through. Just readily available online information for when you're ready to create a design that works for your needs.

We are open for design at vulcraft.com/design-tools

NUCOR®
VULCRAFT

Powerful Partnerships. Powerful Results.

editor's note



The other day I started making pizza for dinner and my youngest casually mentioned he had eaten pizza for lunch. Oops. I asked if we wanted something else, and he just smiled and said, “Law Five.”

Years ago, I wrote up a set of “Scott’s Rules” and number five happens to be “You can never have pizza too often.” (You can view them at <https://bit.ly/slmrules>.)

Given my love of pizza, you can imagine my happiness when a recent episode of my favorite TV show, *Shark Tank*, had a segment on a fantastic outdoor pizza oven. This inexpensive steel (of course) oven allows you to use a variety of fuels, and you can cook a pizza in just a few minutes.

Even better, the oven was created by Eric Bert, a former bridge engineer and AISC member, and his brother Andy.

My favorite moment in the episode was when one of the Sharks extending offers, Barbara Corcoran, said she thought the entrepreneurial brothers were boring and Kevin “Mr. Wonderful” O’Leary responded, “I like engineers.”

I think we can all learn something from this pizza oven.

First, it works well and looks good (the sleek, portable oven cooks a pizza at more than 500 °F in just two to three minutes). Second, it’s versatile (unlike its competitors, you can use propane, wood, charcoal, or pellets). And third, it’s economical (it’s currently listed on Amazon at less than \$300).



Of course, given how attractive, versatile, and economical steel bridges are, and given Eric’s background in steel bridges, would you really expect anything else?

You can check out the *Shark Tank* episode (season 11, episode 15) on abc.com or learn more about the pizza oven at bertello.com. And if my wife lets me, with a little luck I’ll be cooking up some pizzas in my backyard this summer!

Scott Melnick
Scott Melnick
Editor

Modern Steel Construction

Editorial Offices

130 E Randolph St, Ste 2000
Chicago, IL 60601
312.670.2400

Editorial Contacts

EDITOR AND PUBLISHER

Scott Melnick
312.670.8314
melnick@aisc.org

SENIOR EDITOR

Geoff Weisenberger
312.670.8316
weisenberger@aisc.org

DIRECTOR OF PUBLICATIONS

Keith A. Grubb, SE, PE
312.670.8318
grubb@aisc.org

PRODUCTION SPECIALIST

Erika Salisbury
312.670.5427
salisbury@aisc.org

GRAPHIC DESIGN MANAGER

Kristin Hall
312.670.8313
hall@aisc.org

AISC Officers

CHAIR

Jack Klimp, Cianbro Fabrication
& Coating Corporation

VICE CHAIR

Stephen Knitter
Geiger & Peters, Inc.

SECRETARY/LEGAL COUNSEL

Edward Seglias, Cohen Seglias
Pallas Greenhall & Furman, PC

PRESIDENT

Charles J. Carter, SE, PE, PhD

SENIOR VICE PRESIDENT

Scott Melnick

VICE PRESIDENT

Lawrence F. Kruth, PE

VICE PRESIDENT

Mark W. Trimble, PE

Editorial Advisory Panel

Caroline R. Bennett, PE, PhD
University of Kansas

Amanda Dean, PE
Walter P Moore

Bryan Frazier,
Zalk Josephs Fabricators, LLC

Keith R. Griesing, PE
Hardesty and Hanover

Stephen Knitter

Geiger & Peters, Inc.

Advertising Sales

M.J. Mrvica Associates, Inc.
2 W Taunton Avenue
Berlin, NJ 08009
856.768.9360
mjmrvica@mrvica.com

Address Changes and Subscription Concerns

312.670.2401
subscriptions@aisc.org

Reprints

Erika Salisbury
312.670.5427
salisbury@aisc.org



3D steel detailing software designed to optimize your fabrication.

PVS Structures produces quality structural steel products for projects up to 20,000 tons around the world. Top of the line detailing and fabrication software like SDS/2 help make it possible. Learn how PVS Structures is boosting their fabrication efficiency with SDS/2 at SDS2.com/PVS-Structures.

SDS/2 customer Tom Horswill, Robot Technician at PVS Structures in Carter Lake, Iowa

 **SDS/2**
A NEMETSCHek COMPANY

Sit. Stay. Seismic.

The new 3rd Edition **Seismic Design Manual** includes more than 800 pages of comprehensive design examples covering most types of steel and composite seismic force resisting systems, including $R = 3$ systems.



**RETRIEVE
YOURS
TODAY!**

\$100 Members | \$200 Non-Members
aisc.org/publications | 800.644.2400



Smarter. Stronger. Steel.

American Institute of Steel Construction
312.670.2400 | www.aisc.org

If you've ever asked yourself "Why?" about something related to structural steel design or construction, *Modern Steel's* monthly Steel Interchange is for you! Send your questions or comments to solutions@aisc.org.

steel interchange

All mentioned AISC publications, unless noted otherwise, refer to the current version and are available at aisc.org/publications. Modern Steel Construction articles can be found in the Archives section at www.modernsteel.com, and AISC Design Guides are available at aisc.org/dg.

Column Eccentricity

A transfer girder is connected to a hollow structural section (HSS) column using a single-plate shear connection. There is an internal discussion on whether the connection eccentricity can be treated as negligible or should be considered in the design of the girder-to-column connection. Can you offer any direction?

There is a Steel Interchange item in the February 2016 issue that more broadly addresses a common question about eccentricity on columns.

The AISC 15th Edition *Steel Construction Manual* almost universally neglects the eccentricity at the face of the column for standard beam end shear connections. However, when a vertical brace or a truss delivers the shear, the effect of the eccentricity is typically not neglected in my experience. AISC Design Guide 29: *Vertical Bracing Connections—Analysis and Design*, for example, does not neglect the eccentricity. The difference must be assumed to be due (at least in part) to the magnitude of the load.

The rationale discussed in the February 2016 item is as follows: "The restraint a connection provides to the column will help mitigate the eccentric effects in normal framing configurations." It should be noted that here the position is limited to "normal framing configurations," but more importantly, the rationale relies on "the restraint a connection provides to the column." This restraint will generally be greater (I suspect) for a wide-flange column than for an HSS column, not due to any difference in the connection itself but rather due to the inherent flexibility of the HSS wall relative to the out-of-plane actions. Is the restraint at an HSS column still sufficient? Ultimately, it is a matter of engineering judgment. Still, I would be less comfortable neglecting the eccentricity for an HSS column because there will be less restraint provided to the column by the connection when framing to HSS columns.

There is another factor that differs from the "standard" conditions. You indicate that you are considering a transfer girder. This implies big loads to me—more akin to a truss or vertical bracing than the standard shear connections addressed in Part 10 of the *Manual*. Having said this, though, I will also state that I have never seen a "transfer girder" framed to the face of an HSS column using a single-plate shear connection. In my experience, it is more common to see transfer girders framed to wide-flange "jumbo" shapes and built-up box

sections. So perhaps in this case, the loads are not as large as I might imagine.

While it might still be that the effect of the eccentricity is negligible, to me it is not obvious or intuitive that this is the case. Therefore, I would either explicitly account for the eccentricity or do some more calculations to convince myself that I don't need to. The effort required to convince myself I don't need to explicitly account for the eccentricity would likely be as great or greater than the effort required to just go ahead and include the eccentricity. The eccentricity is not neglected, but rather it is somehow relieved and ceases to exist. Eccentricity is often negligible because the simple models used underestimate the effects of restraint (as noted in the Steel Interchange mentioned above) or because the moment can be distributed among multiple elements such that the effect on any given element is quite small. One way to look at this is that if one is not certain that the effect of eccentricity could be explicitly accounted for without changing the size of any element, then the eccentricity is not negligible and should likely be explicitly accounted for in the design.

Larry Muir, PE

Intermittent Fillet Weld Spacing for Tension Members

I am using intermittent welds to connect two shapes. What is the recommended maximum intermittent weld spacing for a tension member?

Section D4 of the AISC *Specification for Steel Buildings* (ANSI/AISC 360) refers to Section J3.5 for the maximum spacing of connectors at plates for built-up tension members. According to Section J3.5(a), "For painted members or unpainted members not subject to corrosion, the spacing shall not exceed 24 times the thickness of the thinner part or 12 in." Note, however, that this is addressing the spacing of bolted fasteners and not intermittent welds.

For intermittent fillet welds, according to Sub-clause 2.12.2.1 in AWS D1.1:D1.1M:2015, "The longitudinal spacing between intermittent fillet welds connecting two or more rolled shapes shall not exceed 24 in." Also, the User Note in Section D4 of the *Specification* recommends a maximum slenderness ratio of 300 for each component between connectors.

Bo Dowsell, PE, PhD

Beam Stability Bracing

I have two girders that support beams at uniform spacing (see Figures 1a and 1b). There is no deck or grating at the top. The beams are connected to the girder with typical shear connections (see Figure 1c). If I use the equations in Appendix 6 of the AISC *Specification*, I calculate a point load



Carlo Lini (lini@aisc.org) is AISC's director of technical assistance.

Bo Dowswell, principal with ARC International, LLC, and **Larry Muir** are both consultants to AISC.

that would need to be resisted, but the resisting element would be the other girder in weak-axis bending. When checking lateral-torsional buckling, how do I determine what the unbraced length is? Should I consider adding horizontal bracing to help brace the girders (again, see Figure 1b)?

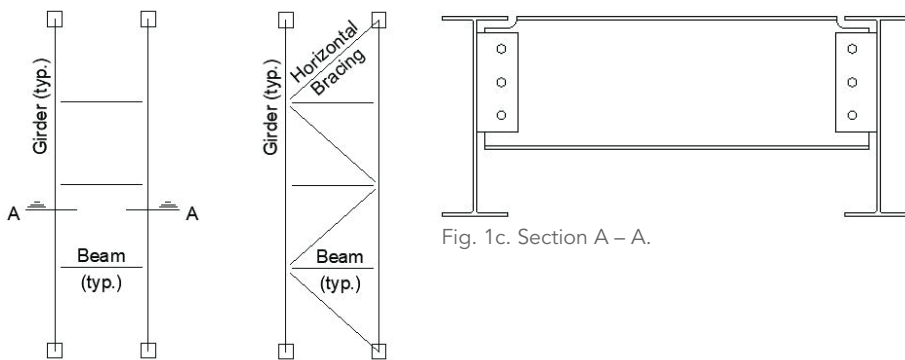

Fig. 1a. Beams only.

Fig. 1b. Beams and horizontal bracing members.

Fig. 1c. Section A – A.

Joseph Yura and Todd Helwig wrote a paper titled “Bracing for Stability,” which provides a lot of great information on bracing beams. You can access it at aisc.org/bracing-for-stability.

Lateral beam bracing is covered on page 12 of the paper. The authors state: “Lateral bracing can be relative, discrete, continuous or lean-on.” Note that what is referred to as relative and discrete bracing is now referred to as panel and point bracing in Appendix 6 of the AISC *Specification*. I believe relying on the beams to brace the girder for the configuration shown in Figure 1a is what the authors refer to as lean-on bracing. The authors provide some additional guidance on lean-on bracing, stating: “Buckling of an individual beam can occur only between the cross members in a lean-on system. No additional bracing requirements are necessary for lean-on systems. If two adjacent beams are interconnected by a properly design cross frame or diaphragm at midspan, that point can be considered a brace point when evaluating the beam buckling strength. Since the beams can move laterally at midspan, the effectiveness of such a bracing system is sometimes questioned. As long as the two flanges move laterally the same amount, there will be no twist. If twist is prevented, the beam can be treated as braced. Tests and theory confirm this approach (Yura, 1992).”

The key here is that we are bracing the girders to prevent twist between the top and bottom flanges, not lateral displacement of the girder itself. Section 6.3 of Appendix 6 Member Stability Bracing of the AISC *Specification* clarifies this, stating: “When a braced point is assumed in the design between points of support, lateral bracing, torsional bracing, or a combination of the two shall be provided to prevent the relative displacement of the top and bottom flanges—i.e., to prevent twist.”

You could try evaluating the configuration shown in Figure 1a as a torsional point brace using Section 6.3.2a of Appendix 6 in the *Specification*. The value calculated for M_{br} per Equation (A-6-9) could be converted into a force couple acting on each girder, which would transfer these forces back to the girder supports. The stiffness would also need to be evaluated. Depending on the stiffnesses you decided to include in this evaluation (stiffness of the beam, girder, and connections, for example), Commentary Equation C-A-6-4 could be used to combine these various stiffnesses.

$$\frac{1}{\beta_{act}} = \frac{1}{\beta_{conn}} + \frac{1}{\beta_{brace}} \quad \text{Eq. C-A-6-4}$$

The configuration shown in Figure 1b, where diagonal members have been added to restrain movement of the top (compression) flange, could be evaluated as a panel bracing (previously known as a relative bracing) using Section 6.3.1a in Appendix 6.

There may also be other models that could be used to determine the unbraced length.

Carlo Lini, PE



Steel Interchange is a forum to exchange useful and practical professional ideas and information on all phases of steel building and bridge construction. Contact Steel Interchange with questions or responses via AISC's Steel Solutions Center: 866.ASK.AISC | solutions@aisc.org

The complete collection of Steel Interchange questions and answers is available online at www.modernsteel.com.

The opinions expressed in Steel Interchange do not necessarily represent an official position of the American Institute of Steel Construction and have not been reviewed. It is recognized that the design of structures is within the scope and expertise of a competent licensed structural engineer, architect or other licensed professional for the application of principles to a particular structure.

A WORLD OF STEEL PROCESSING MACHINERY...

The Solution That Best Fits Your Needs.



BEAM
PROCESSING



EXCALIBUR - VICTORY
Mono spindle CNC
Horizontal Drilling Systems



ORIENT range
Mono spindle CNC
Profile Processing Center



VANGUARD range
Three spindle CNC Profile
Processing Lines



LIBERTY range
Three spindle CNC
Profile Processing Lines



ENDEAVOUR - VALIANT range
Three spindle CNC Profile
Processing Lines



ENTERPRISE range
CNC Gantry Drilling Lines



RAZ - FLEX range
CNC Coping Robot and Systems



KATANA range
Band Sawing Systems



PLATE
PROCESSING



P range
CNC Punching, Drilling
and Marking Systems



TIPO D range
CNC Punching, Drilling
and Cutting Lines



KRONOS range
CNC High definition Plasma
and Oxy Cutting Systems



GEMINI range
CNC Drilling, Milling
and Thermal Cutting Systems



TIPO G range
CNC Drilling, Marking and
Thermal Cutting Systems



TIPO B range
CNC Punching, Marking and
Thermal Cutting Systems



TIPO C range
CNC Punching, Drilling and
Thermal Cutting Systems



ANGLE
AND FLAT
PROCESSING



A range
CNC Punching, Drilling,
Marking and Shearing Systems



SP range
Super Performance
CNC Punching and Shearing Systems



HP range
CNC Punching, Drilling, Notching,
Marking and Shearing Systems



XP range
High performance CNC Punching
and Shearing Lines



RAPID range
CNC Drilling, Marking
and Cutting Systems



SURFACE
TREATMENT



Shot blasting System
Surface treatment systems

A drive to constantly improve, to meet increased demands for higher efficiency and throughput, has made FICEP a global leader for the past 88 years.

Don't just take our word, ask our customers... FICEP equipment owners have seen the results, with unmatched reliability and increased productivity.

Call and let us show you solutions designed specifically for your operation.



FICEP Corporation
2301 Industry Court, Forest Hill, Maryland 21050
Phone (410) 588-5800
Fax (410) 588-5900

www.ficepcorp.com

As a fabricator, time is money, and the margin for errors is non-existent. FICEP Corp. understands and is prepared to help you achieve higher through-put with greater control and precision.

Contact us for solutions that increase your productivity, and join fabricators across the globe who trust the world's leader in steel processing equipment.

steel quiz

This month's Quiz focuses on design considerations of the various 2020 AISC IDEAS² Award winners. All mentioned AISC publications are available at aisc.org/specifications. And to view all of the winners, see our IDEAS² Awards coverage, starting on page 28.

- 1 What is the tallest U.S. building west of Chicago?
- 2 **True or False:** In the manufacturing process of a buckling restrained brace (BRB), the bonding of steel with the mortar is prevented so as not to form a composite section.
- 3 Buckling restrained braced frames (BRBF) are designed so that inelastic deformations under the design earthquake will occur primarily as brace yielding in:
 - a. Tension
 - b. Compression
 - c. Both "a" and "b"
 - d. None of the above
- 4 Which AISC standard contains requirements for a member to be designated as architecturally exposed structural steel (AESS)?
- 5 **True or False:** For an ASTM A500 HSS (hollow structural section) member, the wall thickness used in design, t_{des} , is taken as the nominal wall thickness.
- 6 In an eccentrically braced frame (EBF), for a link length of $2.6 M_p/V_p$ or greater, the link rotation angle shall not exceed ____ rad.
- 7 At what viewing distance should an element be finished to meet the requirements of AESS Category 3?
- 8 Which of the following statements are true about erection requirements for AESS:
 - a. Tack welds not incorporated into final welds shall be ground smooth.
 - b. All bolt heads in connections shall be on the same side, as specified, and consistent from one connection to another.
 - c. Both "a" and "b" are correct.
 - d. Both "a" and "b" are incorrect.

All questions and answers were created by Bhavnoor Dhaliwal, a graduate student at the University of Illinois at Chicago and AISC intern. (Thanks, Bhavnoor!)

TURN TO PAGE 14
FOR THE ANSWERS

No Shop or Field Welding! All-Bolted SidePlate Connections

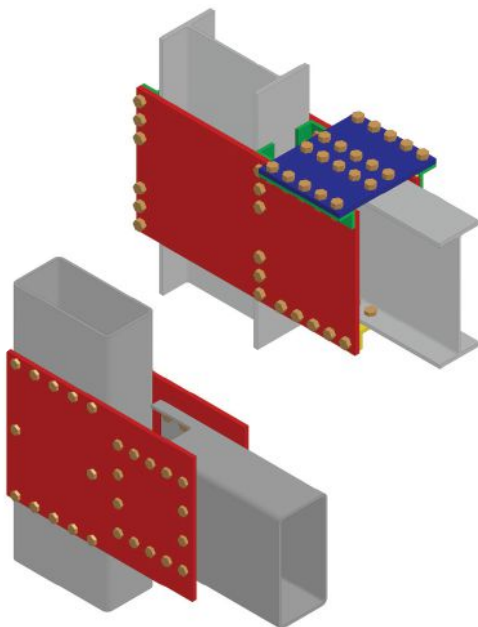

"This new all-bolted connection is something we are really excited about, SidePlate continues to innovate and our partnering relationship allows us to be on the cutting edge of connection technology."

-Marsh Spencer, President SteelFab Inc.

"The new all-bolted HSS solution enables our industry to reduce lead times for steel framed buildings. We look forward to seeing this innovation support a movement in the industry and are excited to be working with SidePlate to make this happen."

-Tom Muth, President of Atlas Tube

949-238-8900
www.sideplate.com

 **SIDEPLATE**[®]
POWERED BY **MiTek**

1-800-801-3648



"Zinc Protects Steel"®

**INNOVATION.
STRENGTH.
LONG-LASTING.**

V&S GALVANIZING

With extensive hot-dip galvanizing experience, we believe in safely doing what we say we'll do and continually investing in our people, our equipment and our experience to ensure Total Customer Satisfaction.

**KETTLE RANGE
30'-56'
IN LENGTH**

**UP TO 85'
PROGRESSIVE
DIP**

**CRANE
CAPACITY
20 TONS**

**DIP AND SPIN
GALVANIZING**

www.HotDipGalvanizing.com

OUR LOCATIONS: Columbus, OH • Memphis, TN
Owego, NY • Taunton, MA • Detroit, MI
Perth Amboy, NJ • New Castle, DE • Jonestown, PA



MOMA TOWER: 53W53 Street, New York, NY

steel quiz ANSWERS

Everyone is welcome to submit questions and answers for the Steel Quiz. If you are interested in submitting one question or an entire quiz, contact AISC's Steel Solutions Center at 866.ASK.AISC or solutions@aisc.org.

- 1 **Wilshire Grand Center.** Completed in 2017, Wilshire Grand Center is a 73-story mixed-use high-rise in downtown Los Angeles. It is steel-framed (with a concrete core wall).
- 2 **True.** A BRB provides separation between the steel and mortar, with the mortar and surrounding steel casing providing restraint against buckling of the yielding segment in the center of the section. If a composite section is formed, this action would not be possible. This is illustrated in Figure C-F4.1 (pictured, right) from the 2016 AISC *Seismic Provisions for Structural Steel Buildings* (ANSI/AISC 341). Note that Wilshire Grand Center incorporates dozens of BRBs.
- 3 **c.** The steel casing and concrete allows inelastic yielding in both tension and compression.
- 4 AESS requirements are found in Section 10 of the AISC *Code of Standard Practice for Steel Bridges and Buildings* (ANSI/AISC 303). Note that IDEAS² winners Belmont Gateway Canopy, Embry-Riddle Aeronautical University Student Union, and Marvin Gaye Recreation Center all prominently incorporate AESS.

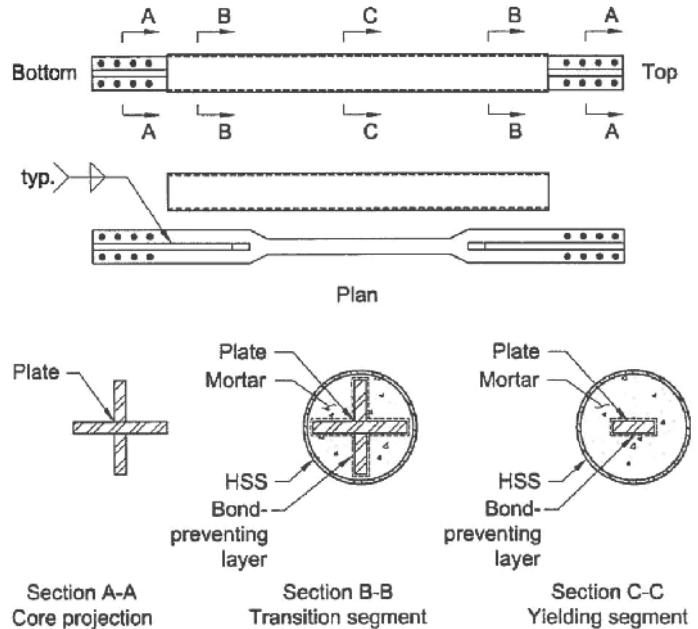

Fig. C-F4.1. Details of a type of buckling-restrained brace (courtesy of R. Tremblay).

- 5 **False.** ASTM A500/A500M tolerances allow for a wall thickness that is within $\pm 10\%$ of the nominal value. Because the plate and strip from which these HSS are produced have a much smaller thickness tolerance, manufacturers consistently produce them with a wall thickness that is near the lower-bound wall thickness limit. Consequently, the AISC *Specification for Structural Steel Buildings* (ANSI/AISC 360) requires, in Section B4.2, that 0.93 times the nominal wall thickness be used for the design wall thickness in calculations. Note that IDEAS² winners Little Charlotte monumental stairs and Hartsfield-Jackson Airport modernization prominently use HSS members.
- 6 **0.02 rad.** Link rotation angle definition and restricted values can be found in Section F3.4a of the AISC *Seismic Provisions*.
- 7 **20 ft.** This is specified in Section 10.1.1 of the AISC *Code*.
- 8 **c.** Both of these requirements must be satisfied according to the Section 10.6 of the AISC *Code*.

A BREAK LIKE THIS COMES ALONG ONLY ONCE IN A BUILDING'S LIFETIME.

AEROLON® IS THE FIRST FLUID-APPLIED COATING TO ACT AS AN EFFECTIVE THERMAL BREAK.

A low VOC, water-based coating that can be easily spray-applied in the shop or in the field, Aerolon provides significant cost-saving advantages over structural thermal breaks, limiting design restrictions for architects and reducing application and labor time for contractors. **Find out more at tnemec.com/thermalbreak.**



Grow your Knowledge with AISC Continuing Education

Education Archives

Did you know that AISC offers 1- to 6-hour presentations on demand? Viewing is free—whether it's during lunch at your office or in your spare time at home on a spring weekend! And if PDHs are what you're after, you can purchase, take, and pass a quiz to earn a certificate. With over 200 hours of options (50 hours added in 2019!), your educational needs are sure to be covered.

aisc.org/educationarchives



Smarter. Stronger. Steel.

American Institute of Steel Construction
312.670.2400 | www.aisc.org

steelwise

SOUND CONTROL

BY ROBERT CONNICK



Robert Connick
(rconnick@acentech.com) is a senior consultant with acoustic consulting firm Acentech.

For more on sound control and noise isolation, see AISC's Design Guide 30: *Sound Isolation and Noise Control in Steel Buildings*, available at aisc.org/dg. (Note that Figures 2–4 are from this Design Guide.)

Tips on designing for sound isolation and noise control in steel buildings.

SOUND, BY ITS NATURE, is not something that can be easily shown on a plan.

Likewise, with the exception of spaces like concert halls or auditoriums, where acoustics is a major determinant of the space's form, it's not something that is often at the forefront of facility design. Still, while it's true that poor acoustics won't make a building collapse, a poor acoustical design can still cripple the usability of the space, leading to invasive and costly modifications down the road.

Among the various aspects of acoustical design, one of the most essential in every type of building is proper sound isolation. But to understand that, we first need to understand what sound is and how it propagates.

Introduction to Sound

Sound is defined as vibration in an elastic medium, whether that medium be air, water, or the steel structure of a building. In practice, sound is often described in terms of two things: decibels (dB), which represents the amplitude of the sound and is perceived as loudness; and hertz (Hz), which represents the frequency of the sound, perceived as pitch, which can be high frequency (an alarm clock beeping or a glass breaking), low frequency (the "thumping" of a subwoofer), or somewhere in the middle (typical speech).

Rather than a definitive value (like feet), decibels represent a logarithmic ratio between two different pressure values: 1) the sound in question and 2) a reference pressure (typically 20 micropascals). A logarithmic scale is used in lieu of a linear scale, because the pressure range for the levels of sound we typically interact with is immense, reaching from 20 micropascals to about 63 pascals (about 3 million times greater). Converted to a logarithmic scale, this range shrinks to a much more manageable 0 dB (at reference pressure: 20 micropascals) to 130 dB (at 63 pascals). This logarithmic scaling also maps well to our perception of a sound's loudness. In general, a sound that is increased by 10 dB will be perceived to be about two times louder, and likewise a sound that is reduced by 10 dB will be perceived to be about half as loud.

The important thing to remember here, with regard to sound isolation in a building, is that the degree of sound attenuation provided by typical building assemblies (or reduction in loudness) is greater with regard to higher frequencies than to low frequencies.

Sound Propagation

When we discuss sound propagation through a building, we are specifically looking at how sound travels from a *source* space (the origin of the sound), through various *paths* (demising walls, ducts, and other building constructions), into a *receiver* space (a nearby room or other area where noise intrusion is a concern). In general, suitable control of intruding noise relies on a good understanding of all three of these components (the loudness of the sound source, the sensitivity of the receiver, and the attenuation provided along the path). Here, we'll focus specifically on the path.

Sound propagation through buildings typically occurs in one of two ways: air-borne propagation (sound waves travelling through the air and then passing into and through, or around, demising assemblies) and structure-borne propagation (sound waves induced directly into the building structure). A common example of airborne sound might be someone talking, while primarily structure-borne sound might be that same person walking up a flight of stairs or stomping their feet. While we address these sources differently, there are some overlaps and transition between the two.

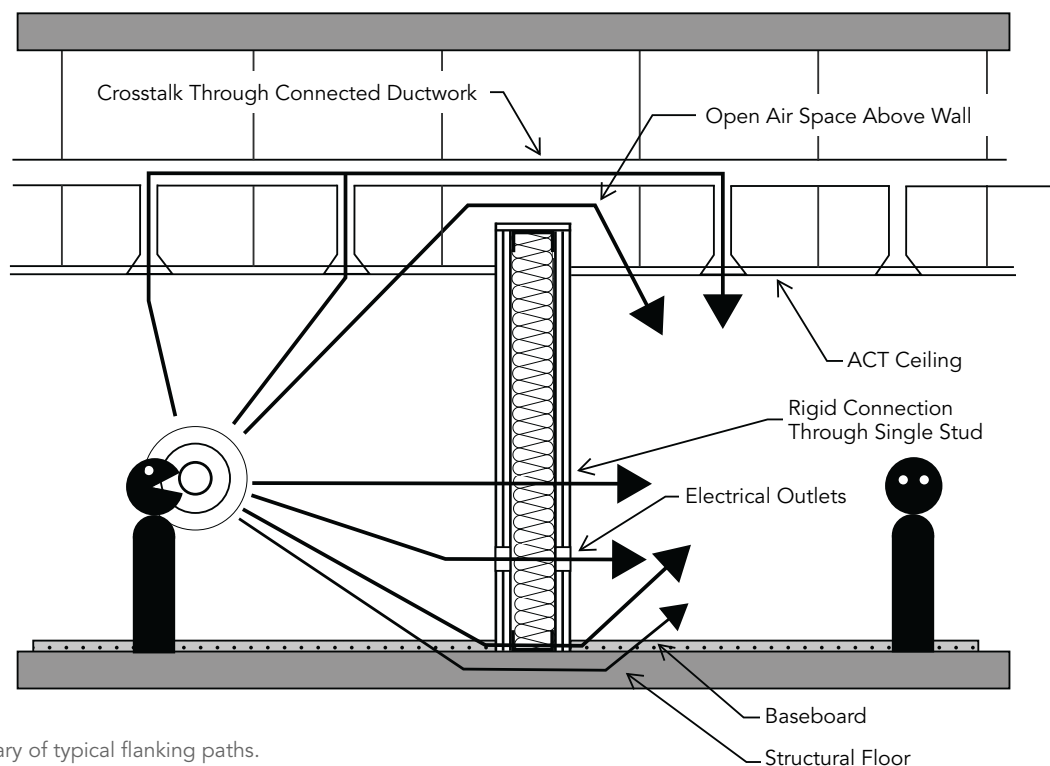

Fig. 1: A summary of typical flanking paths.

When airborne sound impinges on a surface, such as the face of a wall, floor, or ceiling, the energy is split in three ways:

1. Some of the energy is reflected back into the room such that it travels back to the ears of whoever might be inside, possibly “bouncing” off several surfaces along the way. The strength and timing of these reflections is what determines how “reverberant” a room sounds, with stronger reflections leading to a longer, more prominent reverberance (like a church) and weaker reflections leading to less reverberance (a recording studio).
2. Some of the energy is transformed into heat and “absorbed” into the structure.
3. Some of the energy transmits through the structure, continuing its journey via the new medium of the wall, floor, etc.

Each time the sound attempts to pass to a new medium, portions of energy are lost to reflection and absorption, and this is what lies at the heart of both airborne and structure-borne sound isolation.

With structure-borne sound, the same effects are taking place, although typically with fewer transitions; the stomping feet transfer energy directly into the floor structure, which then travels through the structural connections in the building until it is radiated out into the air inside another room, often via a panel—e.g., a gypsum board wall or ceiling.

Because sound can travel through nearly any medium and will take whatever path is available, it is often important to consider not only what might be considered the primary path (such as the demising wall separating two rooms) but every other possible avenue (such as paths around the wall via the floor, ceiling, ducts, electrical outlets, etc.). These circumventing paths are referred to

as “flanking paths” (see Figure 1). In most cases, there are as many solutions to noise transmission through flanking paths as the flanking paths themselves (and more).

Tools for Sound Isolation

Now that we’ve established the basics of how sound propagates through a building, let’s look at the basic tools we use to try to limit that propagation. The general principle of sound isolation is to make the path from one space to another as “difficult” as possible. As discussed above, sound does not like changes in medium, but this is only part of the story.

Mass. Heavy structures are more effective at blocking sound than, say, a curtain for the simple reason that they weigh more. For a given frequency, each doubling of mass leads to a roughly 6-dB increase in the transmission loss (TL), which is a measure of the sound level reduction provided by the barrier. This 6-dB rule is what is referred to as the mass law, which also states that for a given mass, the degree of transmission loss increases by about 6 dB for each increase in octave band. (One octave is a doubling of frequency.) This means that in general, low-frequency sounds are less attenuated by barriers than higher frequencies, which is why you are more likely to hear more of the thumping bass of your neighbor’s music than the vocals.

The mass law is primarily relevant for a monolithic, limp, homogenous structure, like a concrete slab. While a single, heavy mass can be a good starting place, these types of structures can have other limitations associated with the resonance and other properties of the structure itself. In part because of these limitations, it is both acoustically superior and structurally more efficient to construct a two-mass system using a resilient separation.

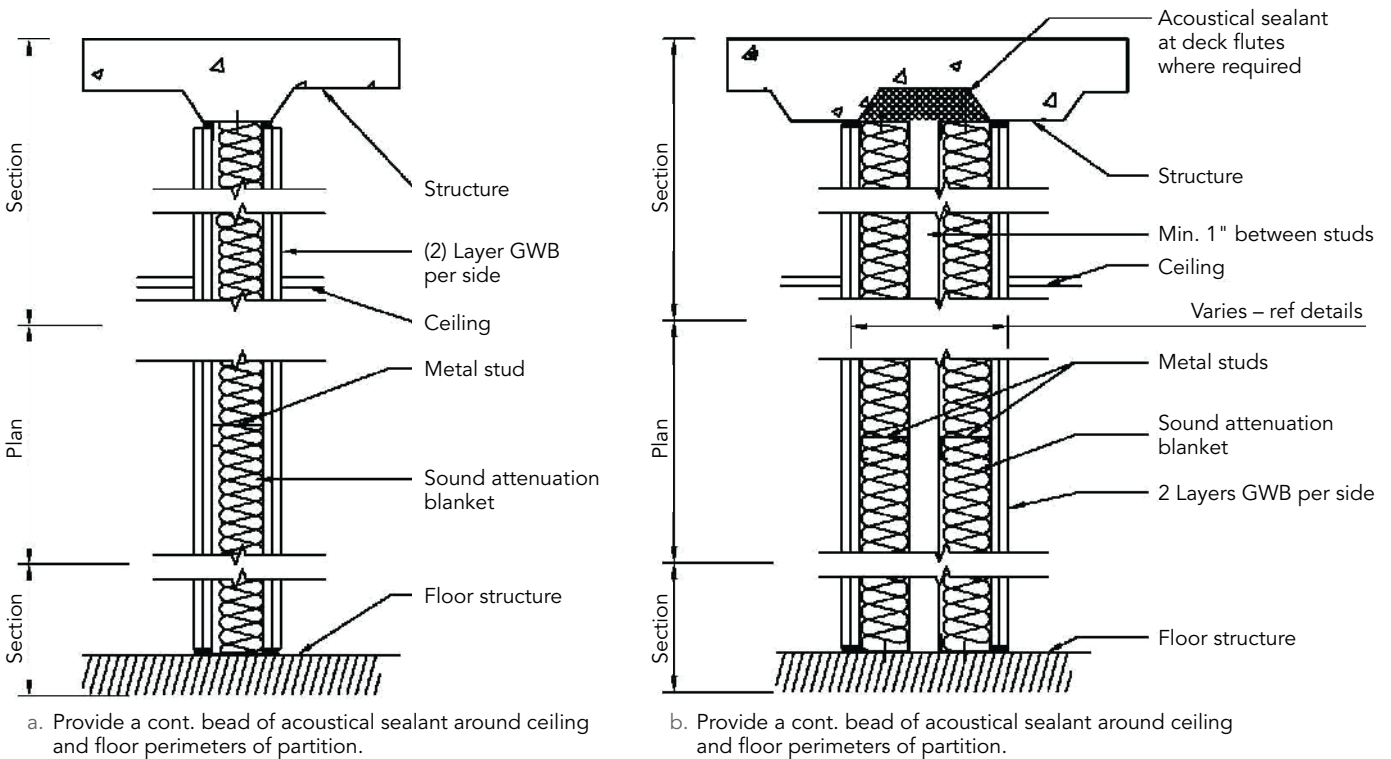

Fig. 2. A single-stud wall (both masses are rigidly connected, allowing easier transmission of sound), versus a double-stud wall (the structural break between the studs reduces sound transmission and improves acoustic performance). These walls have essentially the same surface weight (most of the mass is in the gypsum board) but the double-stud wall provides vastly greater sound isolation performance.

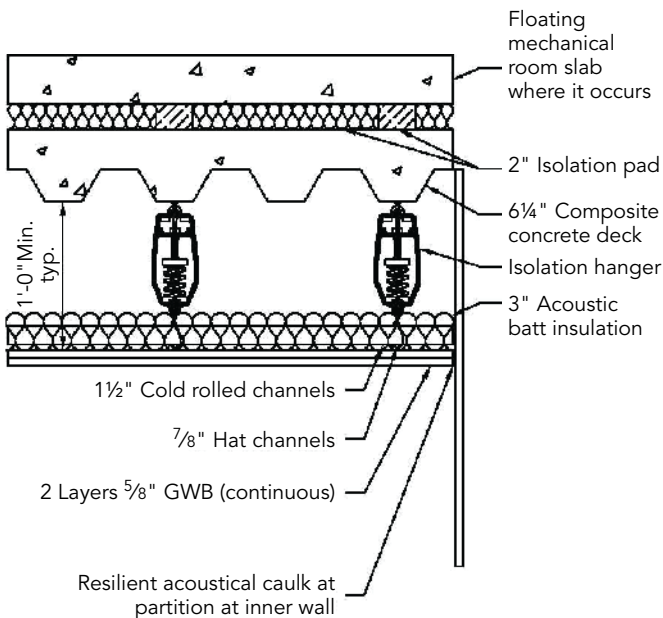

Fig. 3. A robust floor-ceiling assembly with a floating floor and a resiliently suspended ceiling on spring isolators. Often only some of these measures will be needed except at very sensitive adjacencies.

Separation. In a two-mass system (such as a steel/concrete deck and gypsum board ceiling, or a double-wall with two separate rows of studs) the masses are separated by a gap (whether it be via isolation hangers or an unbridged airspace). The benefit here is that you are creating a more resistive path for the sound (it needs to transfer from air to the solid mass, back to the air inside the cavity, and then into another layer of solid mass) before it can reach the adjacent space. Because these separate masses are in close proximity, and never completely separated from each other, the final combined transmission loss of the assembly won't be quite as good as a simple sum of their two individual performances, but it will still be a significant improvement over a single mass.

A two-mass system also helps mitigate the resonances and other internal factors that would lead to specific weaknesses in a single-mass system, although the cavity between the two masses can sometimes create resonances of its own. For this reason, we typically fill those cavities with sound-absorptive material to absorb some of the sound bouncing around inside. These materials also help by dampening the movement of the masses, which helps reduce the amount of energy transmitting through. See Figure 2 for a comparison between two different scenarios of equal mass but significantly unequal transmission loss.

Creating a resilient separation is also effective in mitigating structure-borne noise, whether it be footfalls on a floor or impact noise from bumping furniture against a wall. However, as it is difficult to simply create an air cavity between rooms with no structural connections, we look to resilient pads and isolators such as springs or neoprene that work to reduce sound energy as it tries to pass

through. Because of the added mass and resilient connection, many of these methods can also be effective in mitigating airborne noise. Figures 3 and 4 show some examples of floating floor and resiliently suspended ceiling systems, which are both particularly effective at mitigating both airborne and impact noise between vertically stacked spaces.

In most buildings, good acoustical design involves proper acoustical separation, which means not only understanding the concerns of the spaces (i.e., what kind of noise will be present and who it might affect) and providing the right wall or floor/ceiling assembly, but also addressing the myriad other paths by which sound can travel. Further, while the basics presented here can help set the baseline for the design, the control of sound transmission can be as complicated as many other trades. It is best to consult with someone experienced in acoustical design for the specific type of building at hand. ■

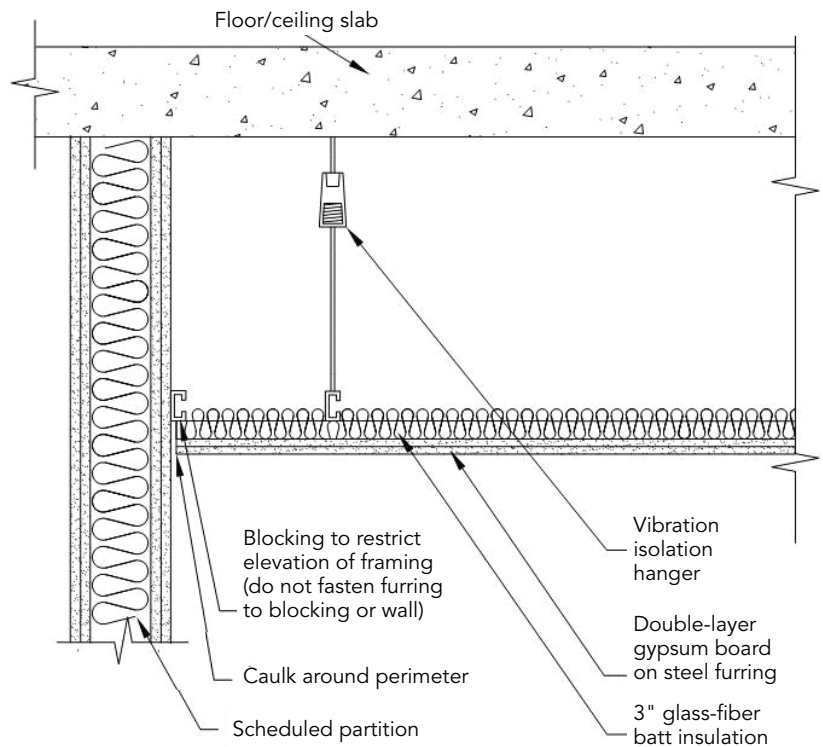

Fig. 4. A typical sound barrier ceiling detail. Less sensitive adjacencies may only require neoprene hangers or clips with the gypsum board suspended much closer to the structure above.

NEW!

**ACCELERATING
YOUR
PERFORMANCE**



VOORTMAN STEEL MACHINERY

ALL-IN-ONE
MACHINE
DO IT ALL IN
A SINGLE
PASS!

IN STOCK NOW!

- ▶ FINANCING AVAILABLE
- ▶ FASTEST ROI



**VOORTMAN
V807** ROBOTIC THERMAL
PROFILE PROCESSOR

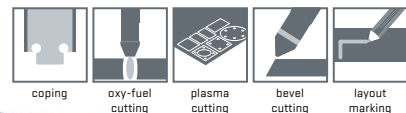

**NEW DESIGN;
SAME PRODUCTIVITY**

- ▶ Footprint reduced 50%
- ▶ Fully automated processing from loading to unloading
- ▶ Copes, rat holes, slots, block outs, seismic connections, layout marking and more
- ▶ Capable of plasma and oxy-fuel cutting; quickly change torch lead sets



VOORTMAN USA

26200 S. Whiting Way +1 708 885 4900
Monee, IL 60449 info@voortmancorp.com
United States of America www.voortmancorp.com



field notes

JUDGE AND JURY

INTERVIEW BY
GEOFF WEISENBERGER



Geoff Weisenberger
(weisenberger@aisc.org) is senior editor of *Modern Steel Construction*.

To hear more from John, visit www.modernsteel.com, where you can listen to the interview podcast in its entirety. And for more on AISC's Student Steel Bridge Competition, see this month's Structurally Sound on page 66.

John Parucki weighs in on 25 years as head judge of AISC's Student Steel Bridge Competition.

WELCOME TO FIELD NOTES, *Modern Steel Construction's* podcast series, where we interview people from all corners of the structural steel industry with interesting stories to tell.

Our subject this time is **John Parucki**, who has been the head national judge of AISC's Student Steel Bridge Competition (SSBC) for a quarter-century. He talks about the competition, what it means to him, how it's changed over the years, and also how many holes-in-one he's hit.

You're the longtime national head judge of the SSBC. How long have you been doing it, and how did you get started?

I've been the national head judge since 1995. Our regional fabricators association started supporting the steel bridge competition in the early 1990s when it was a smaller regional competition. As our members got more involved, I ended up becoming the head judge for the region. Then, one day I got a phone call from [former AISC Director of Education] Fromy Rosenberg, asking, "Would you be interested in being the national head judge for the competition to be held in Buffalo?" Who knew that by saying yes, I'd still be doing this 25 years later!

What was it like judging the first time?

It was stressful. We were putting together the first national competition and working with a large number of teams being invited to participate after competing at a regional level. In those days, the rules were a lot different, and we allowed many things that we don't allow now. Back then, bridges had to span between abutments provided by the host. One of the biggest early changes was that teams had to incorporate abutments as part of their bridge design. The rules are changed from year to year so as to continue to give new design challenges. This competition is still just as exciting as the first day I got involved.

In all your years of judging, were there any particularly memorable experiences?

I think all competitions are memorable in their own way. Each national event is different and they all have their own challenges. Each national host student committee works hard and they are ready to go when we start with the first bridges at eight o'clock in the morning. I've seen a lot of bridges over the years, and it has always amazed me how unique each bridge design is, as well as the methods of construction used to optimize that year's set of rules.

Has the build portion gotten faster and faster over the years?

I tend to think the better teams are quicker, yes, but it doesn't necessarily mean that they're going to be the best team overall. We do have a wide range of build speeds



throughout the year. I think last year, at the national event, we had a range of five-minute builds to 45-minute builds. However, that time is relative because it depends on the number of builders that they use. So a longer build with fewer builders can actually be more efficient than a quick build with more builders.

Would you say the students have changed since you started judging?

I would say yes. I think the students back when I started were more traditional students—18-, 19-, 20-year-olds. Now you see such a blend of students, some with families and/or establishing their second careers after working for ten to twelve years. Their families come to the competition with them. So now we have a wide variety of student backgrounds and more diversity than we had back then. It's funny that I am now judging student competitors whose parents I judged years ago.

It seems like one of the biggest things with the competition is that it's very applicable to the real world.

Yes, we want them to design a bridge that is functional, including fabrication, constructability, and the ability to carry a load, as well as being aesthetically pleasing. We specify a bridge in the problem statement of the rules, but how teams use their engineering skills in designing this bridge can be scaled up into bridge construction as well as building construction. It's all about designing connections and members to hold loads. Teams have to generate shop drawings, and by working with other students, they learn project management and scheduling. Some teams have the facilities to fabricate their own bridges, and some ship their bridges out for fabrication. After fabrication is complete, teams have to construct it under conditions where the rules try to replicate real-world problems using rivers and restricted sites. Then, the team and the judges see how it responds when loaded with 2,500 lb of steel. Many times, especially at the regionals, when

there is a collapse, it's a eureka moment! Teams see these failures in real time in a way that no design software could ever show them. They see how a connection unexpectedly reacted under load that the team did not design for. That might be a lesson they will remember if they continue designing in steel. You learn from your mistakes.

Let's talk a little bit about your history in the steel industry. You used to run a fabrication shop.

After serving in the Air Force, I returned home and got involved in our family-run miscellaneous shop. My brother and I eventually ended up buying the shop and, unfortunately, after a few years and a bad economy, we had to sell. I ended up going to work for a large fabricator, managing their plant. I was then offered a position as president at another fabrication company, where I worked for 20 years until 2003. After that I kept involved by working for a few large fabricators on a number of large projects, doing on-site management and dealing with constructability issues.

So it sounds like you like to play golf. Is that an understatement? Is this a lifelong passion or is it something that's cropped up and recently?

Yes, I started right after leaving the service. I'm a member of a club in my area. I've been lucky to have played Pebble Beach, Doral, Whistling Straits, among others, and I don't really have a favorite course. As they say, any bad day on a golf course is better than a good day at work. I play two or three times a week, when the weather permits since I am from Rochester, New York. It's not like living in Florida!

Have you ever hit a hole-in-one?

No, but I've been within one inch of that hole! However, I've played with a few people who have had a couple of hole-in-ones. It drives me crazy! Why not me? ■

business issues **SMILE, YOU'RE ON CAMERA!**

BY ANNE SCARLETT



Anne Scarlett is president of Scarlett Consulting, a Chicago-based company specializing in AEC-specific strategic marketing plans, marketing audits, and coaching. She is also on the adjunct faculty at Columbia College of Chicago and DePaul University. She can be contacted via her website, www.annescarlett.com.

Video meetings have abruptly evolved from as-needed to must-use for many businesses. Here are some best practices for making the most of them.

IT'S Q2 2020, and the world as we know it has changed.

Video calls are now ubiquitous. Whether using Zoom, Skype, Facetime, Google Hangouts, or countless other video applications, many of us have been expected to abruptly replace in-person interactions with video. It's safe to say that our methods for working together will be forever changed—to what degree, only time will tell.

Video conferencing isn't new, and its benefits have become apparent to many. In the AEC industry, multi-office companies have long collaborated using video conferencing in myriad ways, such as forming high-performance project teams composed of subject matter experts from across the firm. Video conferencing has also cut down on reimbursable travel costs, a savings transferred directly to the client. Corporate cultures from across the world have become more solidified thanks to video conferencing. Cross-training, knowledge transfer, and mentoring are all more abundant and effective. The list goes on and on.

That said, the marketing touchpoints—specifically business development visits to prospective clients—have largely remained as in-person meetings or traditional phone calls. As well, many single-office boutique or small businesses have stuck with traditional modes of communication with business partners and clients.

Until now. Moving forward, video conferencing is likely to be a part of our new normal, long after we've weathered the current crisis. The majority of professionals will become reasonably versed in these tools, and you don't want to be left behind. On the contrary, why not get out in front? Here are some tips on how to make video calls productive and second-nature.

View video calling as an opportunity. Unlike a traditional voice call, now you can read people's body language. Sure, it would be easier in person, but with practice, you'll get the hang of video calls. In addition, a video call allows you to further convey your own messages through nonverbal cues, something that is much harder to do by phone. As a result, you will communicate with far more clarity.

Select the optimal background. For most of us, finding a streamlined background for the video call will make good sense (a blank wall, a well-organized bookshelf, tastefully placed artwork, etc.) Whether your home office space is makeshift or permanent, ensure that the background is tidy. You want your peers to focus on you and your content rather than becoming distracted by background sounds or visuals. In certain programs such as Zoom, you can also be playful by adding a virtual background. Maybe you want to add some humor with a background that includes large stacks of toilet paper, or bunny ears (two fingers) behind your head. Or perhaps you want to exhibit a sense of calm, with an inspirational wonder such as Machu Picchu in the distance. The options for free virtual backgrounds are abundant and growing. In addition, it goes without saying that you'll want to ensure that everyone in your immediate vicinity (partners, children, pets) knows that you are on the video call so that they don't make a cameo appearance while you are explaining your latest design or presenting your project progress report.

That said, depending on the context of the meeting, it can be personable and charming to get a quick peek of your cat sitting by your side or your child's latest doodle hanging behind you. For each meeting, decide how to make the most of sharing appropriate slivers of your personal life.

Present yourself in the best light—literally! Once you've found the best spot to hold your video call, make sure the lighting is top-notch. I recently watched two video calls where the speaker was awash in shadows, as if they were hiding their true identity. This made me question their credibility. Try to have the primary light source come from in front of you—i.e., from behind the recording device (computer, phone, tablet). Eliminate backlighting and play with overhead lighting until you are satisfied that your entire face is evenly and favorably lit.

Get to know the software features. I'm personally learning about new features every day, and it can feel overwhelming. However, familiarity breeds confidence, and the more you take advantage of free help tools and webinars on managing the software, the more comfortable and confident you will be. Allow time for learning rather than scrambling right before the call to become familiar with the interface.

Practice with others, to create a low- (no-) stakes interaction. Before my first time hosting a video meeting with a small group of colleagues, I roped a couple of friends into trying it out. This allowed me to adjust settings, play with recording options, share screens, field chat questions, view multiple participant windows versus a single speaker, use reactions, explore differences between various devices, and all the rest. While I'm still no expert at hosting a video meeting, the practice was extremely helpful.

Adjust settings to protect your privacy. In most video software, you can adjust some simple settings, such as first entering each meeting on mute and sans video. If you are hosting,

A video call allows you to further convey your own messages through nonverbal cues, something that is much harder to do by phone. As a result, you will communicate with far more clarity.



BENT ON SATISFACTION

11 Bending Machines

Easyway and Hardway: Beams, Tubes, Angles, Tees, Channels, Flats, Pipe & Rail

Sheet/Plate

Shearing (to 1/2" x 20'), Forming, Rolling (to 1 1/4"), and Coning

6 Press Brakes

1000 Ton x 30' 750 Ton x 24'
400 Ton x 23' 3-225 Ton x (10', 12', 14')

CNC Machining

Quality

WhiteFab's patented structural bending process minimizes deformation and provides smoother curvatures. Each bent section is verified for accuracy along its arc.

Facilities

170,000 sq. ft. of production area, under roof

**"IF QUALITY IS WHAT YOU NEED,
LET WHITEFAB TAKE THE LEAD"**



Phone 205-791-2011
Fax 205-791-0500
E-mail: sales@whitefab.com
Web: www.whitefab.com



COREBRACE

SUPERIOR SEISMIC PERFORMANCE

BUCKLING RESTRAINED BRACES
 SIMPLIFIED DESIGN
 SIMPLIFIED INSTALLATION
 SIMPLIFIED COSTS

Contact CoreBrace at:
 5789 West Wells Park Road, West Jordan, UT 84081 801.280.0701
 corebrace.com

Hope it's tight?



with
Torque Control



1 800 552 1999
 1 802 460 3100

Know it's tight!

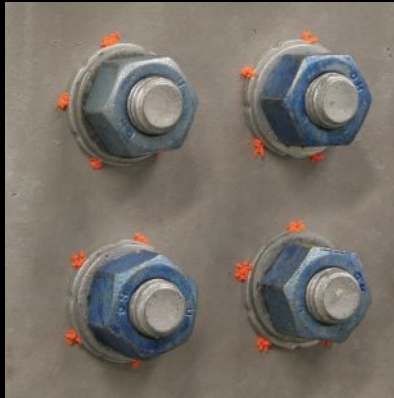

with
DuraSquirt® DTIs

the best way to bolt!

info@appliedbolting.com
 appliedbolting.com

business issues

you can often set it so that *everyone* enters on mute/sans video. This gives people time to get settled so that you won't see or hear something that you'd rather not. (After all, we're not all seasoned news anchors.) And If you are screen-sharing at some point during the call, take care that you are showing only what you want to show rather than all items open on your computer.

Dress for success. You've likely already heard this solid work-at-home advice: Dress as if you are actually going into work. This simple tip psychologically prepares you to be in work mode. Whether you are holding a video meeting with a client for a virtual tour of their project or a video call with a prospect to win new business, dress as you always would for those meetings. It will make the participants "experience" you as the professional person that you are.

When you're the speaker, exhibit your very best presentation skills. Just like in a live presentation, be mindful of your body and paralanguage on video calls. Refined body movement is essential. For example, if you are a gesticulator like me, be mindful that gestures must match your tempo and your messaging. In general, only your torso and shoulders will be visible, so any gestures should be deliberate, just to accentuate a key point. The same holds true with other body movement, such as shifting around in your seat, touching your face and hair, or fidgeting in a manner that causes distraction. If used in moderation, some level of movement can add some interest and engagement, such as reacting with a smile, head nod, tilt, etc. As well, make sure that your vocal delivery remains engaging (not monotone!) with inflection and strong volume.

Position yourself to enhance eye contact and appearance. Depending upon your device of choice, you may be in a situation where it appears as though you are looking off at an angle rather than directly at the other speakers. Do you what you can to keep your eyes aimed towards the camera to create solid eye contact.

Also, consider what your best angle is. It might seem vain, but you will be less distracted by your own image (which shows up on the screen in most programs, unless you alter the settings) if you look reasonably good. My personal preference is to position the laptop on a stack of books so

that it's elevated. This causes me to look slightly up rather than down, framing my head and shoulders. Experiment with various angles and distances. You can also adjust settings to make yourself look good, including Zoom's "Touch up my appearance" feature.

Squelch any and all technical difficulties. Don't be *that* person, distracting or delaying the meeting due to a host of avoidable issues. Instead, check to see if you need to pre-download software; sync and test your microphone with the program; confirm a strong WiFi connection to ensure your screen will not freeze; and so forth. Rather than scrambling to fix the last-minute issues, you'll come across as smooth and in control.

Invest in a few inexpensive tools. If you decide to use your smart phone as opposed to a computer (particularly if your computer doesn't have a video camera), then consider investing in a mini tripod to hold the phone. Similarly, if you think you could have issues with background sound, echoes, or crackling, then purchase headphones with a mic to obtain clearer audio and to eliminate extraneous sounds. Small (but important) accessories can make a big difference.

Above all, practice by recording yourself. If you take away nothing else from this article, please record yourself on practice videos until you are satisfied. Can it be a bit painful to watch yourself? Maybe at first. But you must trust me on this: Whether you are presenting by video or in person, watching a self-recording is the fastest way to improve. With a discerning eye, you can then more objectively witness how others "experience" you—from body language to paralanguage to managing visual aids. You'll be able to quickly experiment and make adjustments on all of the aforementioned tips. Further, you'll have a better firsthand understanding of the feedback that you may later receive from others on your performance.

And keep this tip in mind if you go the Zoom route: All Zoom subscribers, even free accounts, have the ability to record locally to their devices. You can initiate a solo meeting, record it, and then voila! This gives you the ability to assess and adjust your overall performance. Even if your colleagues opt to use a different

video calling platform, having the Zoom account will be an easy way for you to emulate various scenarios in advance.

In these days of flux, no one expects perfection when it comes to video calls. As long as you give it your best shot and remain authentic during the call, you'll experience a human-to-human connection that will be productive, useful, and real. And best of all, when in-person meetings become common again—and they will—video calls will still likely need to be an important part of your business communication repertoire, and you'll have already hit the ground running. ■



Behind schedule? JGM gets you back on track.

Partner with JGM – We're there when you need help the most.

When a large DOT bridge project needed extra horsepower, they chose JGM to hit their aggressive schedule milestones. JGM quickly completed 30 overlength girders including complete joint penetration web to flange welds each weighing 32,000 pounds. Order restored and timelines met with JGM.

Why JGM?

- D1.5 fabrication able to meet the demands of any state DOT
- AISC Advanced Bridge and Fracture Critical endorsements
- Heavy lifting and hauling capabilities to ensure your logistics stay on track
- Close proximity to the Northeast Corridor
- Submerged arc welding equipment for efficiency gains
- In-house CWI's with non-destructive testing certifications

When you need it yesterday, JGM is ALL IN.



610-873-0081 | solutions@jgmusa.com



JGMUSA.COM

Winners Choose Chicago Metal TO Curve Steel



2015 IDEAS² Merit Award - 73 pieces of curved 8" sch 40 pipe totaling 35 tons for Circuit of the America Observation Tower. Austin, TX



2014 SEAIO Best Project - Elliptically curved trusses rolled from 5" and 8" diameter AESS pipe for Institute of Environmental Sustainability at Loyola University. Chicago, IL

2007 IDEAS² National Winner - 400 tons of 12" square tubing curved for the retractable, lenticular room trusses at the University of Phoenix Stadium. Phoenix, AZ

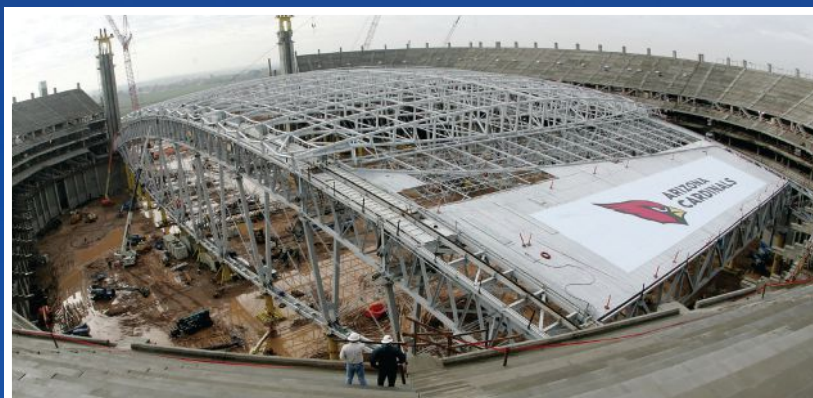

2005 EAE Merit Award - 570 tons of 12", 14", 16", 18" and 20" pipe curved for the Jay Pritzker Pavilion. Chicago, IL



2003 IDEAS² National Winner - 300 tons of 5" square tubing curved 45° off-axis for the Kimmel Center. Philadelphia, PA

Call us at 866-940-5739 to make *your* next project a winner!

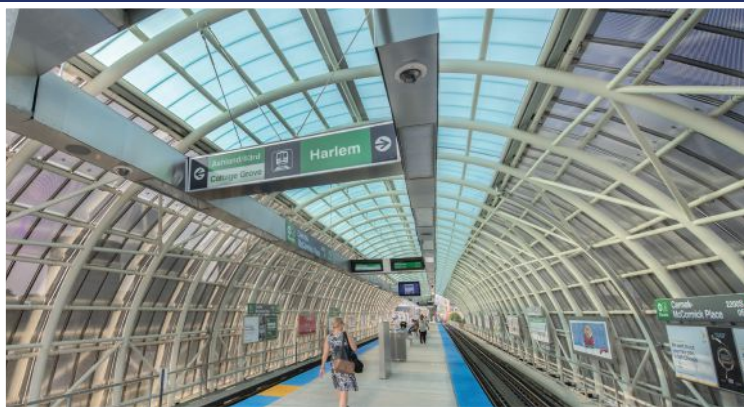

2015 AIA Distinguished Building Award - HSS 8" pipe featuring an ellipse curvature with multi-radius bends for the structural ribs for CTA Cermak-McCormick Place Station. Chicago, IL



2012 IDEAS² Merit Award - 133 tons of 16" pipe curved for the Rooftop Tiara of the Great American Tower at Queen City Square. Cincinnati, OH



2011 IDEAS² National Winner - 420 tons of rectangular tubing, pipe and beams for the roof at the Norman Y. Mineta San Jose International Airport. San Jose, CA

2013 IDEAS² Merit Award - 3600 pounds of pipe each curved with multiple radii for a solar canopy to recharge batteries on electrical vehicles. Chicago, IL



2007 NSBA Special Purpose Prize Bridge Award - 152 tons of 18" pipe curved in our Kansas City plant for the Highland Bridge. Denver, CO



2010 NCSEA Award Winner - 200 tons of beams, channels and angle for the roof of the University of Illinois at Chicago Forum. Chicago, IL



**CHICAGO METAL
ROLLED PRODUCTS COMPANY**

CHICAGO • KANSAS CITY

cmrp.com



IDEAS² AWARDS 2020

A PUBLIC TRANSIT CANOPY that invokes a waterfall—or a giant blue butterfly wing. An office stairwell that appears to defy gravity. A supertall mixed-use tower with a hotel lobby at the top. A hospital boasting the country’s first use of viscous wall dampers.

They’re all steel-framed. And they’re all winners.

Specifically, these four projects, as well as five others, are winners of this year’s AISC IDEAS² Awards

Why “IDEAS²?” Because the program recognizes Innovative Design in Engineering and Architecture with Structural Steel. Awards for each winning project are presented to the project team members involved in the design and construction of the structural framing system—including the architect, structural engineer of record, general contractor, owner, and AISC member fabricator, erector, detailer, and bender-roller.

New buildings, as well as renovation, retrofit and expansion projects, are eligible, and entries must meet the following criteria:

- A significant portion of the framing system must be wide-flange or hollow structural sections (HSS)
- Projects must have been completed between January 1, 2017 and December 31, 2019
- Projects must be located in North America
- Previous AISC IDEAS² award-winning projects are not eligible

This year’s six judges considered each project’s use of structural steel from both an architectural and structural engineering perspective, with an emphasis on:

- Creative solutions to the project’s program requirements
- Applications of innovative design approaches in areas such as

connections, gravity systems, lateral load-resisting systems, fire protection, and blast protection

- The aesthetic impact of the project, particularly in the coordination of structural steel elements with other materials
- Innovative uses of architecturally exposed structural steel (AESS)
- Advancements in the use of structural steel, either technically or in the architectural expression
- The use of innovative design and construction methods such as 3D building models, interoperability, early integration of steel fabricators, alternative methods of project delivery, and sustainability considerations

A panel of design and construction industry professionals judged the entries in four categories, according to their constructed value in U.S. dollars:

- Less than \$15 million
- \$15 million to \$75 million
- \$75 million to \$200 million
- More than \$200 million

National and Merit honors were awarded in all categories except \$75 million to \$200 million. In addition, Sculptures/Art Installations/Non-Building Structures National and Merit winners were also selected.

The IDEAS² Award program also recognizes the importance of teamwork, coordination, and collaboration in fostering successful construction projects. Awards will be presented to project team members at ceremonies held at each of the winning projects throughout the year.

2020 Judges

Kari Berg, AIA

Senior Project Manager/Construction Manager,
UrbanWorks

Kari is a licensed architect with more than 30 years of experience in architecture, interior design, and construction project management. With a background in a wide range of projects including multifamily residential, commercial, office, banks, and healthcare, her balance of architectural knowledge and construction acumen ensures high-quality built projects for UrbanWorks, where she serves as a senior project manager/construction manager. Prior to joining UrbanWorks, Kari served as a senior associate and architectural manager at various architecture firms for more than 10 years, followed by working and managing design-build and GC construction services for over 15 years. Kari earned a B.S. in Architectural Studies from the University of Illinois.

Cynthia Duncan

Director of Engineering, AISC

Cynthia Duncan is AISC's director of engineering. As secretary of the AISC Committee on Specifications and the AISC Committee on Manuals, Cynthia oversees the planning and development of AISC technical publications, including standards, manuals, design guides, and *Engineering Journal*. Having been at AISC for most of her career, she works with technical committees involving volunteer educators, consulting engineers, and industry representatives to develop AISC standards and manuals. Most notable are the *Specification for Structural Steel Buildings* and the *Steel Construction Manual*. Her involvement began with the 1st Edition *Load and Resistance Factor Design Manual of Steel Construction* and includes the 15th Ed. *Steel Construction Manual*. Cynthia's education includes a B.S. in Architectural Engineering at University of Colorado, Boulder, and a Master of Engineering-Civil (Structures) from Cornell University.

Christine Freisinger

Associate Principal, Wiss, Janney, Elstner Associates

Since joining WJE, Christine Freisinger has been involved in the investigation, evaluation, and repair of a variety of structures, including stadiums, warehouses, parking garages, low-rise buildings, and high-rise buildings. Her projects have included documenting the condition of existing structures, evaluation of structures under a variety of design and proposed loading conditions, and development of repair drawings. Christine's structural investigations have involved steel, timber, concrete, and masonry structures, and she has significant experience with structural analysis computer software programs. While attending the University of Minnesota, Christine completed her Master's thesis on the load rating and load testing of horizontally curved composite steel girder bridges. She designed and completed a truck load test on an in-service bridge in Duluth, Minn., to research the load ratings of horizontally curved bridges according to AASHTO.

Christina Koch

Editorial Director/Associate Publisher, *retrofit*

Under Christina's direction, *retrofit* magazine has won several awards, including national AZBEE Awards for editorial and design. Prior to joining *retrofit*, Christina was the editor of several nation-

ally circulated trade magazines, including a residential remodeling magazine and a commercial green building magazine. Christina has traveled extensively across North America and Europe, meeting with architects, engineers, contractors, and manufacturers to learn about innovations and successes in design and construction. She is active in industry trade associations and has been interviewed by well-known news organizations, including *The New York Times* and San Francisco's KTRB-AM 860 radio station. She considers interviewing former Chicago mayor Richard M. Daley to be her most memorable professional experience.

Hollie Noveletsky

CEO, Novel Iron Works

Hollie Noveletsky is the CEO of Novel Iron Works, a family-owned WBE-certified AISC member structural steel fabricator located in Greenland, N.H. Hollie is a past president of Steel Fabricators of New England and a current board member of AISC.

Sheryl Van Anne

Project Executive, Mortenson Construction

With more than 20 years of experience in the construction industry, Sheryl Van Anne serves as a project executive in Mortenson's Chicago office. Since joining Mortenson in 2003, Sheryl has helped build more than \$500 million in large-scale projects throughout the Chicagoland area. Her primary responsibilities are working with clients to deliver their projects on time and within budget. She does this through strong communication, a heavy emphasis on preconstruction analysis to align the program and budget, and ensuring the project undergoes a thorough review for constructability. Sheryl earned her B.S. in Civil Engineering from Missouri Science and Technology. She is a member of the Society of College and Urban Planning (SCUP) and has presented multiple times to the Illinois Community College Chief Financial Officers (ICCCFO). In 2016, Sheryl was selected as one of *Building Design + Construction's* 40 Under 40 and was named one of *Constructech's* 2018 Women in Construction.



The 2020 judging panel, from left: Cynthia Duncan, Hollie Noveletsky, Christine Freisinger, Christina Koch, Kari Berg, and Sheryl Van Anne.

.....

These six judges weighed each project's use of structural steel from both an architectural and structural engineering perspective, with an emphasis on creative solutions to the project's program requirements; applications of innovative design approaches in areas such as connections, gravity systems, lateral load resisting systems, fire and/or blast protection; aesthetic and visual impact of the project; innovative use of AESS; technical or architectural advances in the use of the steel; and/or the use of innovative design and construction methods.



Jim Pearson



Gerard Nieblas

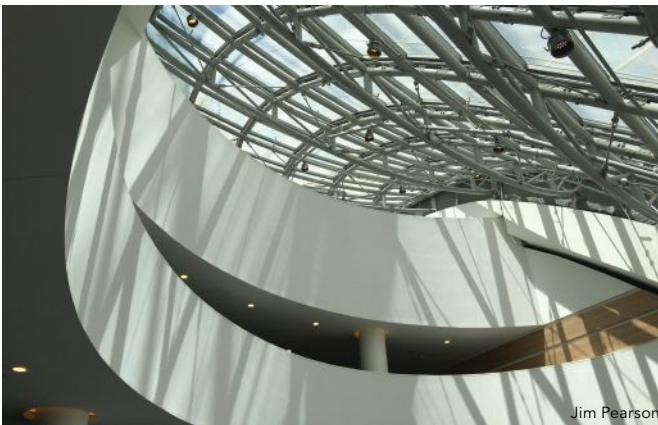

Jim Pearson

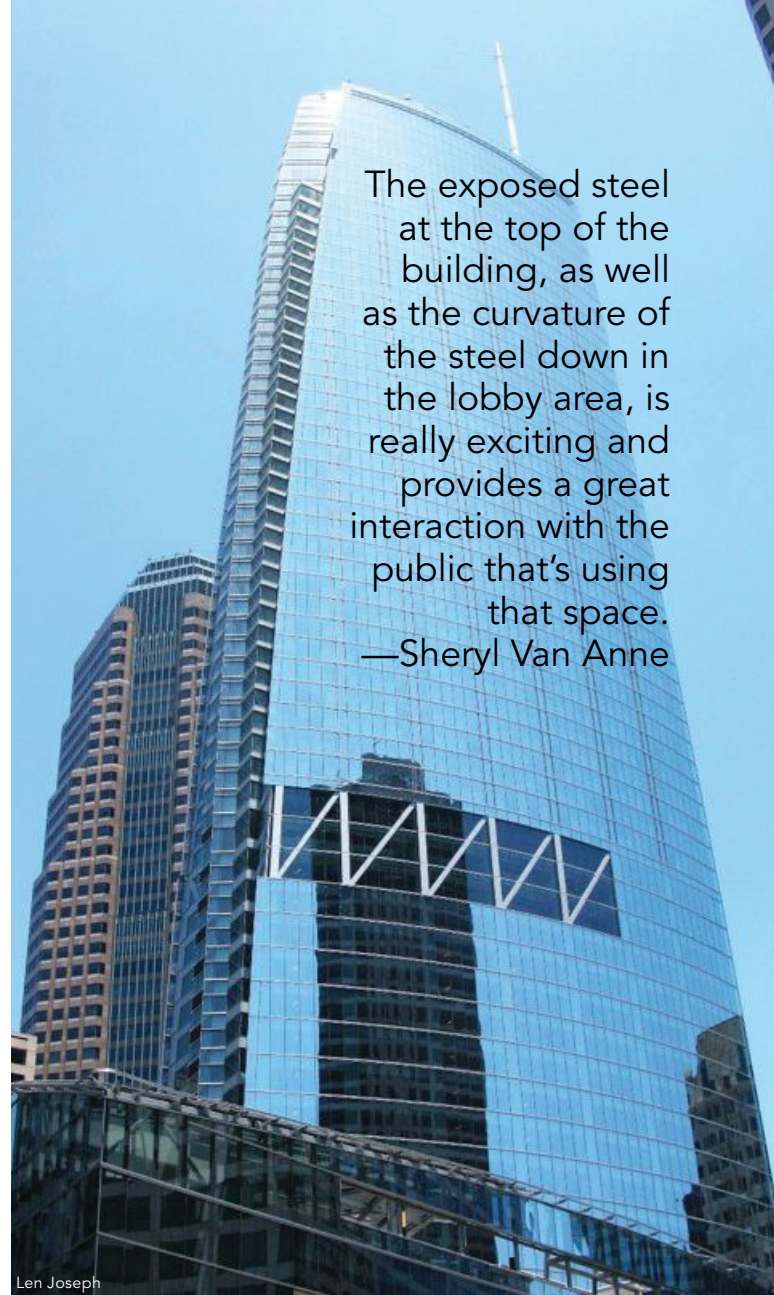

Len Joseph

The exposed steel at the top of the building, as well as the curvature of the steel down in the lobby area, is really exciting and provides a great interaction with the public that's using that space.
—Sheryl Van Anne

NATIONAL AWARD Greater than \$200 Million Wilshire Grand Center, Los Angeles

WILSHIRE GRAND CENTER is the best in the west.

The 73-story steel-framed tower in downtown Los Angeles is the tallest building west of Chicago and the tallest building in the United States outside of that city and New York. Built for a cost of \$1.3 billion, the tower and its podium structure comprise approximately two million sq. ft of space. The upper 43 stories house a 900-room InterContinental Hotel—whose lobby is at the top floor—and the lower 30 stories are reserved for office space. A five-level subterranean parking structure provides space for approximately 1,000 vehicles.

The structural steel-framed tower is geometrically complex, with many of the steel columns sloping over their height to accommodate the curved edges of the structure. Between the 28th and 30th floors, the exterior building columns slope inward 6 ft over three floors to transition the floor plate configuration from office to hotel space. The tower's columns are embedded the full depth of the 18-ft-thick concrete mat foundation to anchor seismic uplift forces.

The design team implemented a performance-based design methodology to accommodate the owner's desire for floor-to-ceiling glass in the hotel and office spaces. A code-prescribed lateral design would have required a perimeter lateral system on the structure in addition to the concrete core wall. This would have resulted in deep perimeter beams that would have either increased the floor-to-floor heights or reduced the heights of the perimeter windows—as well as increased construction time in order to add a perimeter moment frame.

The building is designed to be linearly elastic for a service-level earthquake with a 43-year return period, and for collapse prevention for the extremely rare 2,475-year return period earthquake. To achieve this performance, the design team created three buckling-restrained brace (BRB) regions over the height of the structure. A total of 180 BRBs distribute lateral overturning forces to the exterior concrete-filled steel box columns.

At the top of the structure are ten 2,200-kip BRBs extending from floors 70 to 73, and the single-pin connections for these

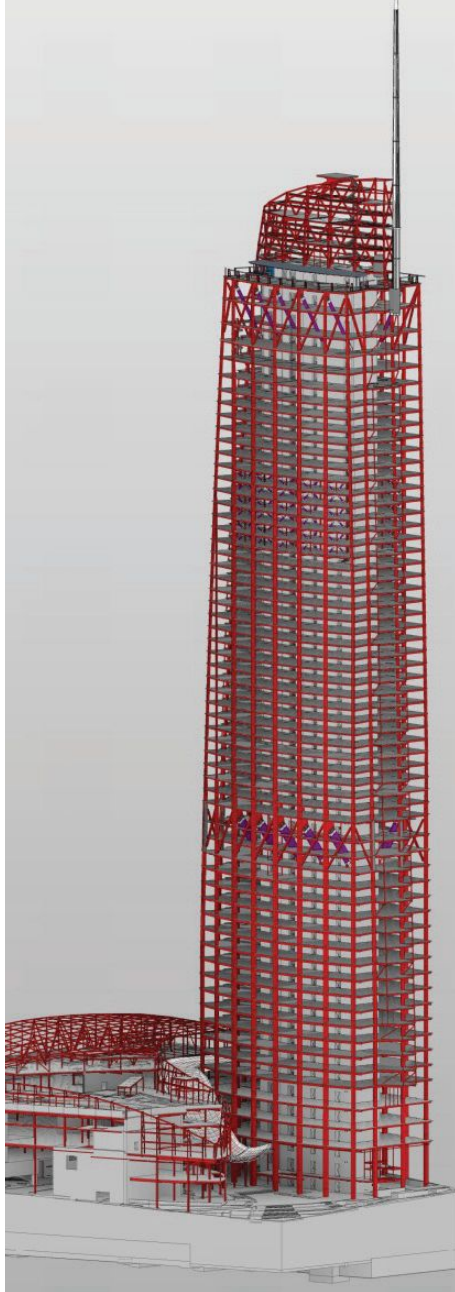

braces are exposed with a patina finish in the hotel lobby for all to see. Between floors 53 and 59 are 130 800-kip BRBs, with each spanning only one floor and hidden in the hotel room demising walls—a unique configuration that allowed the developer to maximize the hotel room count. Closer to the bottom of the structure, between floors 28 to 31, are 40 2,200-kip BRBs. Bundled in groups of four at ten locations, they span three floors and are capable of resisting 8,800 kips at each location.

The extensive system of BRBs is complemented by perimeter belt trusses around the exterior between levels 28 and 31 and levels 70 and 73. These elements all work together to provide torsional resistance and load path redundancy.

The five-story podium—which also employs structural steel framing, along with concrete shear walls—contains restaurants, retail space, meeting rooms, ballrooms, and a rooftop pool. The podium and tower are seismically separated over the building's ground-floor lobby, which is covered by an undulating, curved glass roof that pays homage central California's Merced River. Steel trusses, comprised of round hollow structural section (HSS) members, frame the roof and are rigidly attached to the podium at the tower with slip connections designed to move up to 15 in. in any direction.

Wilshire Grand Center is featured in the February 2017 article "West Coast Boast," available at www.modernsteel.com.

Owner

Hanjin International Corporation, Los Angeles

General Contractor

Turner Construction Company, Los Angeles

Architect

AC Martin Partners, Inc., Los Angeles

Structural Engineer

Brandow & Johnston, Los Angeles

Performance-Based Design Consultant

Thornton Tomasetti, Los Angeles

Steel Team

Fabricator and Erector

Schuff Steel Company, San Diego 

Detailer

BDS VirCon, Brisbane, Australia 

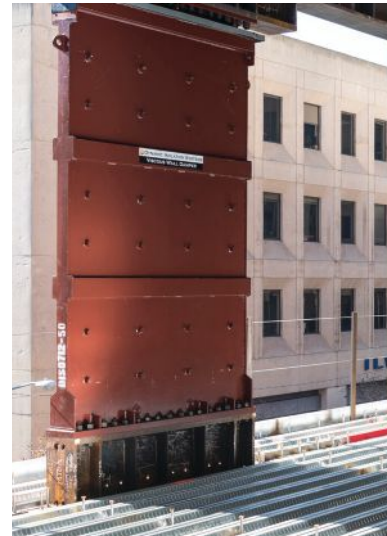
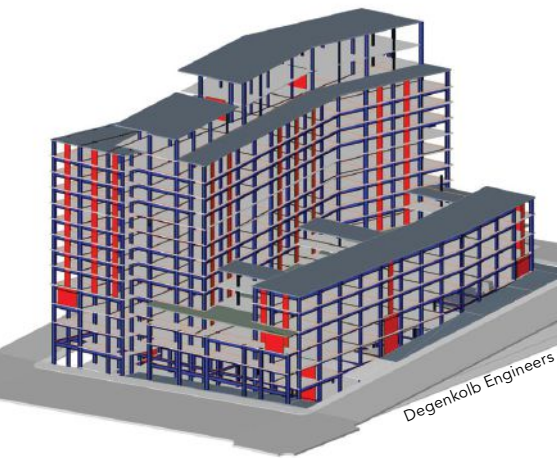

The project advanced the use of viscous wall dampers in the U.S. market to address seismic concerns. —Hollie Noveletsky



MERIT AWARD Greater than \$200 Million Sutter Health CPMC Van Ness Campus – Viscous Wall Dampers San Francisco

A NEW SAN FRANCISCO acute care facility is not only at the forefront of healthcare, but also structural design.

The new \$2.1 billion Sutter Health California Pacific Medical Center (CPMC) Van Ness Campus is a 13-story, 989,230-sq.-ft hospital with 274 patient beds and state-of-the-art diagnostic and treatment centers. It is also the first use of viscous wall dampers (VWDs) in the U.S. The building's 119 VWDs are installed behind the façade on the nine above-grade floors of the 13-story skeleton and will help the facility remain open even after a shock as strong as the 1906 San Francisco Earthquake, which registered a magnitude of 7.9.

Van Ness Campus Hospital (VNC) consolidated the acute care services of two older Sutter Health CPMC campuses to create this new flagship hospital, which opened to patients in March 2019. Given the location in a famously high-seismic city, structural engineer Degenkolb and the rest of the design team studied several seismic-resisting systems via an integrated project delivery (IPD) approach, eventually settling on VWDs. Originally developed and implemented in Japan over the past three decades and seismically superior to more traditional systems, VWDs had never been used in the U.S., nor had the system been reviewed or approved by California's Office of Statewide Health Planning and Development (OSHPD).

Degenkolb led a team effort to validate the technology, implementing full-scale testing of the dampers at the University of California, San Diego. Based on nonlinear analyses, the VWD system is expected to absorb nearly 90% of the earthquake energy at the design earthquake level. It also reduced the weight of the steel framing by one-third compared to a conventional steel moment resisting frame, thanks to its ability to control inter-story drift. This helped reduce the cost of the overall structural system by 25%, which more than offset the cost of the dampers.

The design and construction teams worked together in a "Big Room" across from the construction site. Daily and weekly Big Room meetings kept the project on schedule, even as new team members were still learning how to function in

an IPD environment. The IPD method streamlined the entire process by allowing HerreroBoldt, Sutter Health, and SmithGroup to collaborate from start to finish, with design consultants and contractors working together as early as the validation phase. The team analyzed, scheduled, quantified, and documented the design in real time, reducing waste in the design and construction of the hospital. Additionally, Degenkolb worked closely with the steel fabricator, The Herrick Corporation, to drive the VWD production.

In addition, a building information modeling (BIM) approach provided the ultimate coordination, allowing the IPD team to "build" the hospital in the virtual world before going to the site to build the real structure. The entire team was able to observe each other's work and adjust systems and components before they created real-world clashes. When steel fabrication began, the IPD team had a strong need to monitor the progress and sequence of steel fabrication in the shop. To create an effective method for reporting progress across the structural steel supply chain, the various team members established a standard process for collecting, verifying, and integrating field data to the model to produce a weekly report.

The Sutter Health CPMC Van Ness Campus cleared the way for other structures to implement VWD technology in California and beyond. Future U.S. buildings will now be able to take advantage of this system, which creates the opportunity for improved seismic performance, especially in critically important acute care facilities following powerful earthquakes.

Owner

Sutter Health, Sacramento, Calif.

General Contractor

HerreroBoldt, San Francisco

Architect

SmithGroup, San Francisco

Structural Engineer

Degenkolb, San Francisco

Steel Fabricator and Erector

The Herrick Corporation,
Stockton, Calif.



NATIONAL AWARD \$15 Million to \$75 Million
Mori Hosseini Student Union at Embry-Riddle Aeronautical University, Daytona Beach, Fla.

THE NEW MORI HOSSEINI STUDENT UNION
at Embry-Riddle Aeronautical University is a soaring example of symbolic design.

Inspired by the gracefulness of birds in flight, the building is an expression of the school's mission to teach the science, practice, and business of aviation and aerospace. Sited to serve as the front door to Embry-Riddle's Daytona Beach, Fla., campus, the facility's gently soaring form creates an iconic identity for the university and embodies its student's values of fearlessness, adventure, and discovery.

Key to embodying the ethos of Embry-Riddle in architectural form is the exuberant and creative structural steel expression that illustrates movement, flight, and aerodynamics both externally and internally. The curving bowed roof on top of the structure not only provides solar shading from the harsh Florida sun, but also invokes sinuous avian forms. The vertical, exposed struts convey a feather-like quality and are structural members that tie down the curved roof form from wind uplift, particularly in terms of hurricanes. The massive exposed double arches that wrap the exterior support the vertical roof struts at the shading overhang and signify the main entrances to the building. Internally, an exposed 200-ft curving steel arch bisects the middle of the plan and supports a glass roof above, allowing students the ability to look skyward while inside. The building's architecturally exposed structural steel (AESS) is an integral design element and helps create an exterior and interior aesthetic that feels finished and dynamic.

Programmatically, the 177,000-sq.-ft student union building is an aeronautical athenaeum combining social learning spaces, an events center, club offices, student affairs offices, career services, dining, and the university library. A soaring triple-height commons area integrates the collaborative social and learning environments. The lounges, dining venues, group study rooms, club and organization offices, career services, student affairs, and library wrap the commons and lead to a multistory amphitheater—a place to see and be seen—that overlooks the commons and building entry. The events center, which can accommodate events for up to 900 people, is housed on the first floor and employs long-span trusses to create a clear and column-free uninterrupted floor space. The top floor houses the university library, which is set beneath the dynamic 200-ft arching skylight that opens to the sky. A roof terrace on the second floor allows students to gaze upon the adjacent runway of Daytona International Airport and beyond to rocket launches from the Kennedy Space Center at Cape Canaveral.

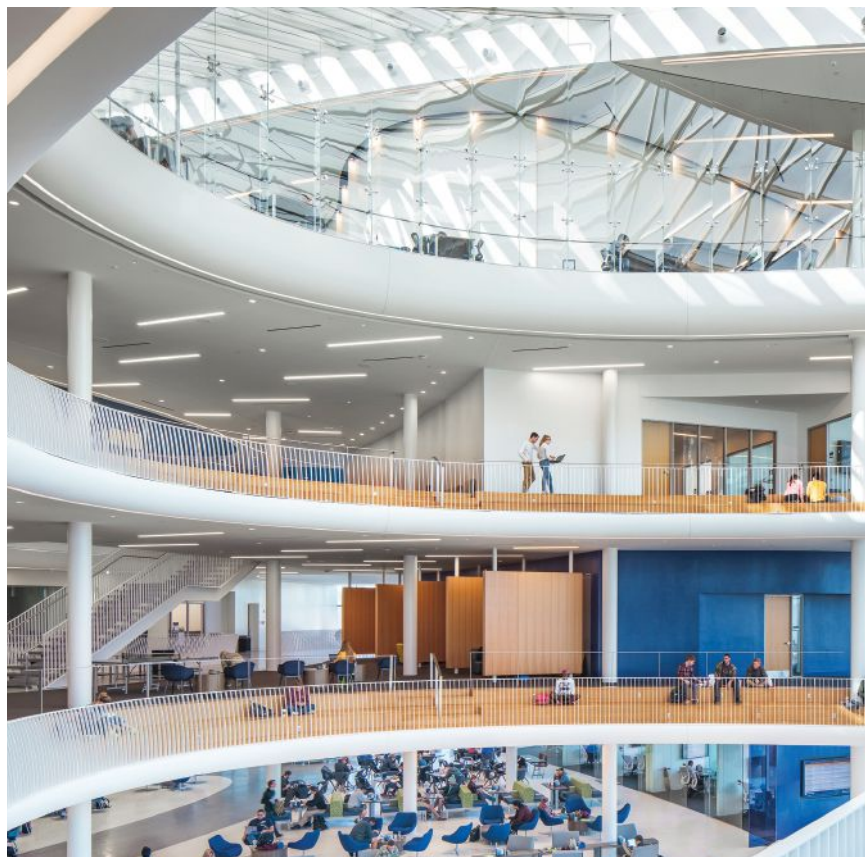

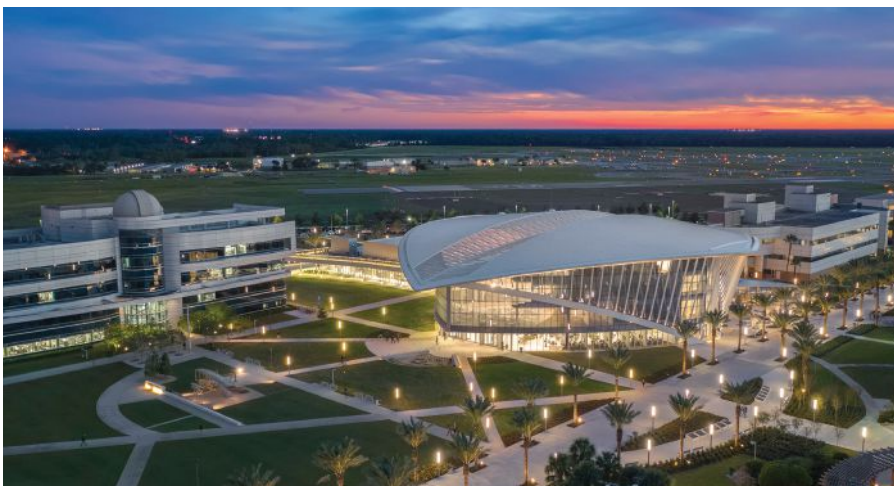

Crucial to creating such a structurally expressive building was the architect's and structural engineer's commitment to work hand-in-glove during the design phase to properly detail the facility's expressive steel forms and connections. Working in both Rhino and Tekla Systems, the design team created a 3D virtual model of the project that was then turned over to the steel fabricators and erector to bring the idea to reality. During construction, the design team periodically visited the multiple fabricators involved in the project to answer questions and observe the progress of the steel before arrival on-site.

In addition to solar shading, the great curving roof also collects rainwater and siphons it to below-grade cisterns for storage and campus irrigation, just one of a number of sustainable approaches that make the student union a high-performing and resource-efficient building. Additionally, the lighting design strategy reinforces and highlights the architectural forms and spaces that are inspired by flight. The lighting further enhances the airiness of the structure and creates a series of identifiable program zones within the larger open flexible spaces to provide activity rooms without walls. In reinforcing the organic architectural expression of the spaces, the overall effect creates a glowing beacon at the campus entry.

The Mori Hosseini Student Union at Embry-Riddle Aeronautical University is featured in the November 2019 article "Winging It," available at www.modernsteel.com.

Owner
Embry-Riddle Aeronautical University,
Daytona Beach, Fla.

General Contractor
Barton Malow Company, Orlando, Fla.

Architect
ikon.5 architects, New York

Structural Engineer
Thornton Tomasetti, Newark, N.J.

**Connection Designer and
Erection Engineer**
McGill Engineering, Tampa, Fla.

Steel Team
Fabricators
Steel, LLC, Scottsdale, Ga. 
Greiner Industries, Inc., Mount Joy, Pa. (also Bender-Roller) 
Fabco Metal Products, LLC, Daytona Beach, Fla. 

Erector
Superior Rigging and Erecting Company, Atlanta 

MERIT AWARD \$15 Million to \$75 Million
Canyon View High School, Waddell, Ariz.

THE NEW CANYON VIEW HIGH SCHOOL in Waddell, Ariz., was driven by energy-efficiency goals.

And its structural system was a driving factor in meeting them, becoming the centerpiece of the design conversation early on as the key element to providing flexible learning environments that extend to comfortable outdoor spaces. The design team’s exposed structural steel framing concept allows natural lighting to penetrate deep into the learning spaces and creates a unique experience seldom found in a traditional high school.

The new 231,000-sq.-ft high school in suburban Phoenix extends beyond the built environment into the realm of how a building interacts with people, resulting in an unprecedented design that elevates learning. A first-of-its-kind learning “Accelerator” contains unique and flexible space imagined and executed through spatial agility in modern, real-world curriculum. And towering solar structures shade the central “Agora” spanning the entire length of the campus, maintaining a peak tem-

perature of 85 °F. In addition, this 225 KW photovoltaic system reduces solar radiation while contributing 20% of the energy needed for the campus.

Early designs traversed buildings made from the two primary framing systems—steel and masonry—throughout campus. However, working with contractor Chasse Building Team, architect and structural engineer DLR Group realized labor savings by separating the two building types on either side of the Agora. By rearranging all of the steel buildings to the north side and all of the masonry buildings to the south side, the build team cut nearly two months off the schedule, thus streamlining the work and having both steel and masonry subs working simultaneously. Early and continued collaboration with the contractor and steel fabricator during the design phase allowed the team to validate cost, detailing, and constructability. Ultimately, this collaboration was instrumental to the success of the project and recognizing the school district’s overall program and design goals.

This high school breaks all the norms of institutional architecture. It actually makes the classroom seamlessly flow into the outside environment. If I were going back to school now, this is the high school I would want to go to.
—Cynthia Duncan



Bill Timmerman



DLR Group



Thomas Reich

Exposing the structural elements as opposed to hiding them behind finishes helped further reduce the project budget, as well as demonstrates to students, faculty, and visitors how typically hidden structural framing elements can create stability, enclosure, and aesthetic contributions. The structural steel-framed buildings form flexible academic “Forts” that create high volumes for daylighting and extensive shading for the outdoor space. Movable space partitions and mobile, flexible furniture create the spatial agility required for the district’s curriculum. In addition, the combination of building-supported and freestanding cantilevered steel structures that make up the solar components are patterned after the human DNA genome and serve as yet another learning tool for students.

When it came to the Accelerator, the two masonry buildings were bridged via long-span steel framing, which created a cohesive framing and lateral system without introducing a building expansion joint and secondary support/bracing systems. With the space anchored by two masonry buildings on each side, the long-span joist and joist girder system allowed for minimal columns, and the masonry buildings created lateral stability for the interior steel framing. In addition, the roof diaphragm design helped resolve

the rotational force to the masonry shear walls on each side of the Accelerator and auditorium spaces.

A high-tech school called for high-tech design solutions. The use of animation and virtual reality were key to communicating the design and functionality of the spaces to the client and students. The contractor used 360° photography during construction to help document embedded systems for quality control and future maintenance. Aerial drone imagery was also used to document construction progress to share with the design team, school district, and community.

Owner

Agua Fria Union High School District #216, Avondale, Ariz.

General Contractor

Chasse Building Team, Tempe, Ariz.

Architect and Structural Engineer

DLR Group, Phoenix

Steel Erector and Detailer

Schuff Steel Management Company, Mesa, Ariz.



Bill Timmerman

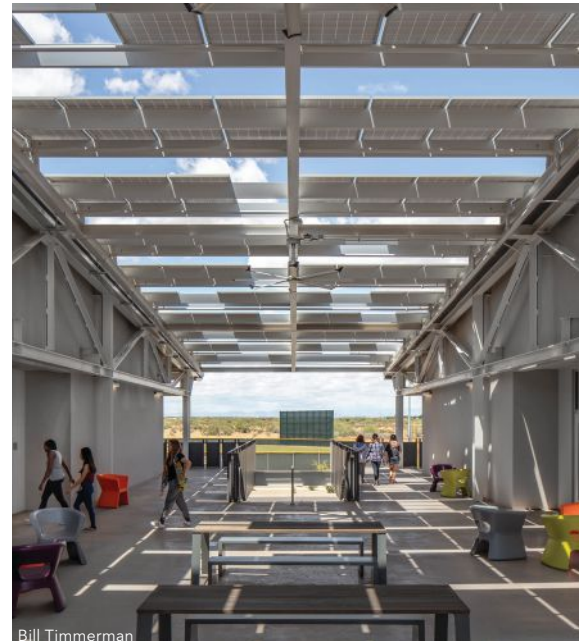

Bill Timmerman



Bill Timmerman



Thomas Reich

NATIONAL AWARD Less than \$15 Million
Hinterland, Green Bay, Wis.

WHETHER OR NOT YOU'RE a Green Bay Packers fan, you can't deny that the new Hinterland Brewery has a primo location.

It also has a primo structural steel design. Inspired by the industrial architecture of the Great Lakes region, the restaurant and functioning brewery is the cornerstone of a mixed-use development within a stadium entertainment district—and it sits right across the street from the Packers' storied stadium, Lambeau Field. The simple palette of materials—steel, brick, and glass—was selected to express careful workmanship and highlight the detailed process of the building's construction. Like the quality grains, hops, and water used in the brewing process, these fundamental building materials were the ingredients used to shape the experience throughout—and steel was the predominant material used to achieve these design goals.

The building is organized by a spine of structural steel frames that serve as both the primary lateral and gravity systems. The roof elements are structural steel bents fabricated from complete joint penetration (CJP) welded wide-flange sections, and the framing evokes early twentieth-century factories and brings a unique form to the rooftop, giving the structure its distinctive shape and filling the interior with daylight.

The roof is a standing-seam steel roof system, with steel members and purlins dominating the expression of the interior spaces. The exposed steel aesthetic extends throughout the interior detailing of various areas, such as a mezzanine that overlooks and surrounds the brewing equipment, to express both strength and artistry. The pigmented lacquer that protects the interior steel permanently captures the industrial feel and preserves the grease pencil markings placed on the steel at the time of fabrication. Two sculptural stairways escort patrons between floors of the restaurant space, with steel plate guardrails serving as stringers to provide both support and enclosure for the stairs; wood treads complement the steel. In addition, much of the building's exterior is clad in a raw weathering steel rain screen.

This new home for a brewery that started more than twenty years ago—and whose previous location was a few miles away in the city's Broadway District—has allowed Hinterland to improve its quality and increase its capacity. Business has grown exponentially since the brewery moved into its new home, with much of the credit for that success going to its design and exposed steel aesthetic. And its proximity to one of the shrines of the NFL doesn't hurt.

Owner

Hinterland, Green Bay, Wis.

Architect

ROSSETTI, Detroit

Structural Engineer

SDI Structures, Ann Arbor, Mich.

**Steel Fabricator, Erector, Detailer,
and General Contractor**

Schuh Construction, Inc., Seymour, Wis. 

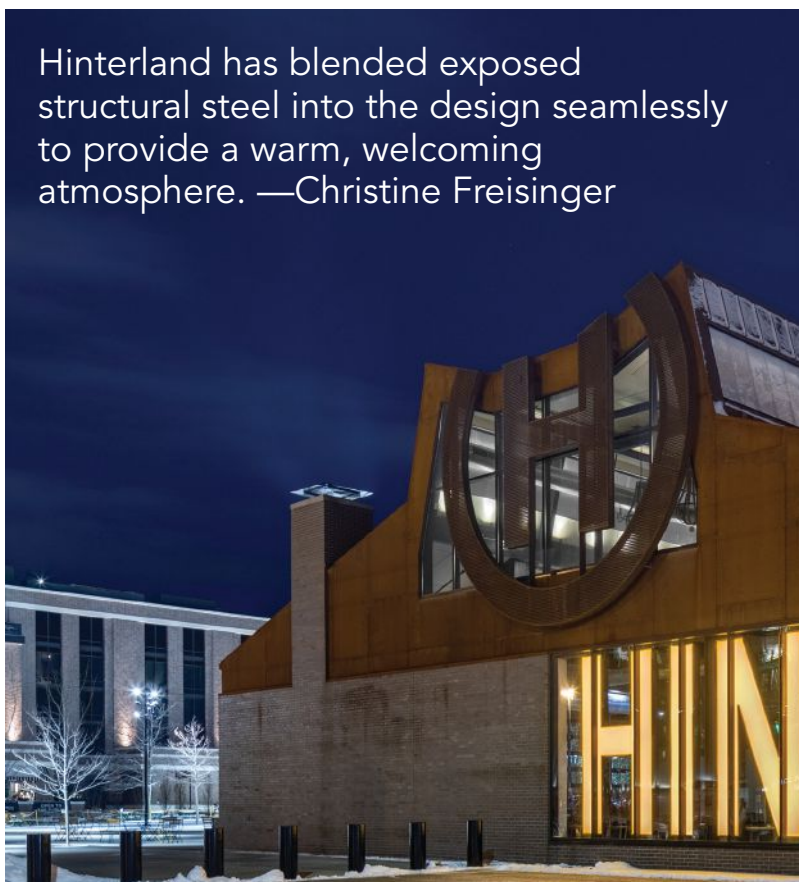
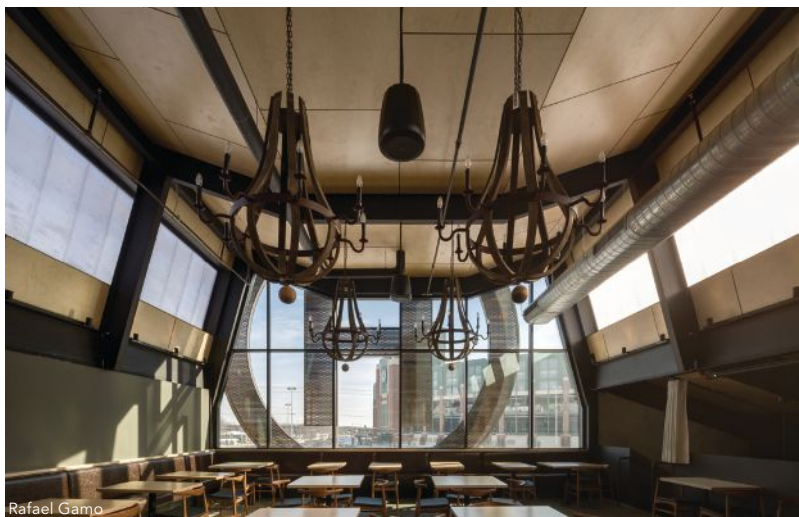

Hinterland has blended exposed structural steel into the design seamlessly to provide a warm, welcoming atmosphere. —Christine Freisinger



Rafael Gamo



John Disbrow

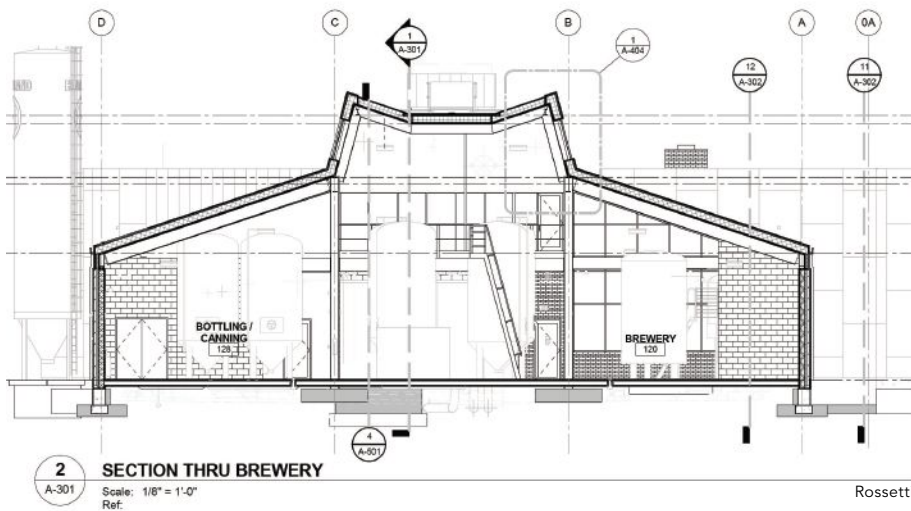

Rossetti



Rafael Gamo



Rafael Gamo

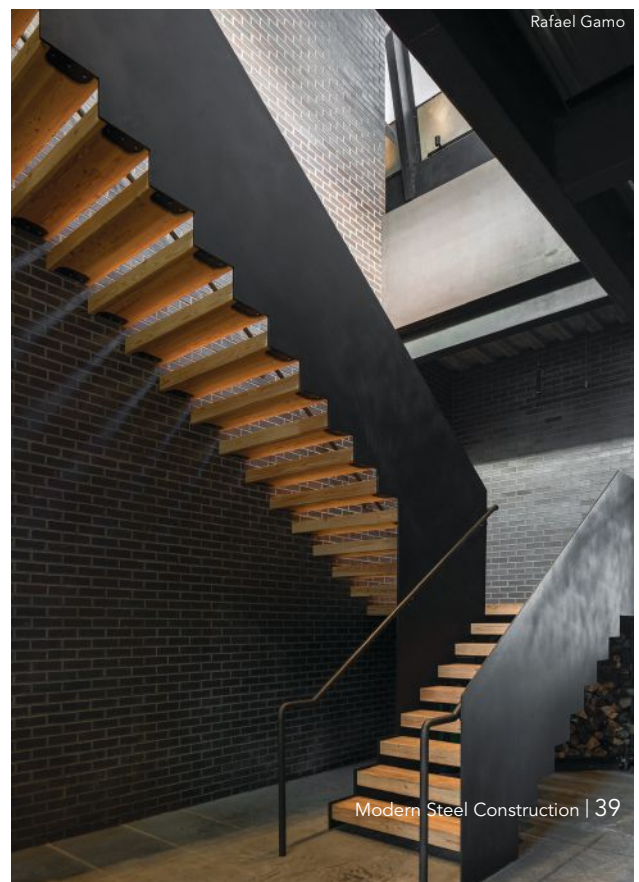

Rafael Gamo

MERIT AWARD Less than \$15 Million
Marvin Gaye Recreation Center, Washington

WHILE MANY of Washington’s famously grand edifices are named for prominent politicians, a new recreation center honors another American legend—and a native of the nation’s capital: singer, songwriter, producer, and one of the creators of the Motown sound, Marvin Gaye.

The new facility, the Marvin Gaye Recreation Center, is elevated above a 100-year floodplain to bring visitors into the tree canopy as steel girders, supported by angled columns, cantilever the second floor over an adjacent stream. The strength of structural steel brings the resilience needed for withstanding floodplain requirements and creates a light and tensile touch to the final design.

Bordering a do-not-build floodway and located within the floodplain, the tight constraints limited the location of the build-

ing on the site itself. The project team took one of the site’s largest challenges and turned it to an opportunity, creating a building that cantilevers into the tree canopy above the stream, offering individuals a unique vantage point to the neighboring surroundings. In order to cantilever the balcony above the stream, the steel columns had to be angled to avoid the floodway. While they are necessary to carry the structural loads, the angled steel is elevated beyond that duty to become a prominent design feature. The design of the columns was an iterative and collaborative effort between the architect and structural engineer, with the engineer sharing the structurally required column angles and locations while the architect responded to coordinate site constraints, ADA clearances, and alignment to the architectural concept.

The Marvin Gaye Recreation Center celebrates structural ingenuity as it cantilevers above an adjacent stream into the tree canopy by using angled steel columns to make use of a challenging site.

—Christine Freisinger



HOACHLANDER DAVIS PHOTOGRAPHY

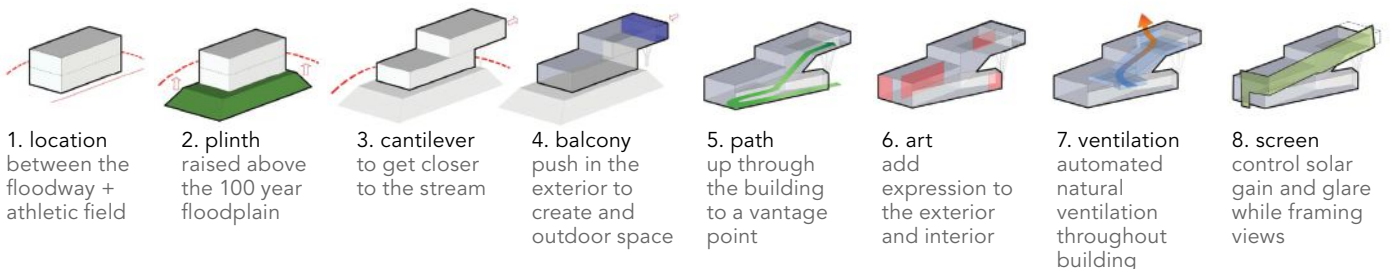

HOACHLANDER DAVIS PHOTOGRAPHY



ISTUDIO ARCHITECTS

Implementing “wash and wear” materials is a necessity for a recreation center, and using exposed steel accomplished the structural goals while also providing a durable, long-term solution to create a low-maintenance facility. In keeping with the theme of sturdy materials, the building is clad with perforated façade panels (also steel) that are designed to withstand stray soccer balls and such from the heavily used recreation fields adjacent to the building. The perforated metal façade also functions as mechanical screening for the rooftop units, controls solar heat gain and glare to reduce mechanical loads, and creates unique views from the second floor.

One of the key coordination items for the project’s design-build team was determining how to connect the screen back to the building’s steel frame. The solution came in the form of steel outriggers, welded to the structural beams, that protrude from the building to accept the screen’s support clips

(with thermal break elements separating the outriggers from the screen).

In addition to its protective and shading functions, the screen also gives the building its identity, drawing the eye and creating a neighborhood icon—especially at night, when the building glows like a lantern in a previously underserved neighborhood in the far eastern reaches of the District.

Owner

Department of General Services, Washington

General Contractor

MCN Build, Washington

Architect

ISTUDIO Architects, Washington

Structural Engineer

Simpson Gumpertz and Heger, Inc., Washington



HOACHLANDER DAVIS PHOTOGRAPHY



HOACHLANDER DAVIS PHOTOGRAPHY



HOACHLANDER DAVIS PHOTOGRAPHY



ISTUDIO ARCHITECTS



HOACHLANDER DAVIS PHOTOGRAPHY

NATIONAL AWARD

Sculptures/Art Installations/Non-Building Structures Hartsfield-Jackson Atlanta International Airport Modernization, Atlanta

HARTSFIELD-JACKSON ATLANTA International Airport (ATL), the busiest in the world, recently looked to transform its 40-year-old terminals by introducing a new architectural icon.

But a question emerged: How could ATL modernize without impacting ongoing operations and risking its title as the world's most efficient airport? The airport's planners initially envisioned fabric-covered steel canopies. However, they were structurally problematic as they required new support columns along the terminal curbs, and foundations that would have been extremely disruptive to airport facilities located beneath the curbside.

The design team began examining how the canopy might connect to the terminal without the need for new columns at the terminal curb. A threefold solution emerged that incorporated: an in-depth investigation of the terminal's structural integrity; HOK STREAM, a custom-built program that allows for rapid design evolution and analysis; and the use of lightweight steel and ethylene tetrafluoroethylene (ETFE) cladding that would form a beautiful free-span structure. Using STREAM—developed by design firm HOK's engineering group—which performs steel design and optimization, the team developed an alternative canopy design that distributed two-thirds of the structure's load onto new support piers located near the parking garages, reducing the increased demand and associated retrofit work to the terminal columns by 75%. This process, which typically would have lasted several months, took only three weeks from start to final owner acceptance of the design.

The dual 864-ft-long canopies feature curved hollow structural section (HSS) steel Vierendeel trusses. The compression chords of the trusses are connected by a diagrid. The trusses span 174 ft and are supported along one edge by 10-ft-deep by 21-ft-tall concrete piers, and at the other edge on bearing pads atop the existing terminal columns. Both canopies support two pedestrian bridges that thread through the diagrids, connecting parking garages to the terminal. The sweeping form of the diagrid canopy represents the most efficient structural load path and is key to the canopy design. While it was found that the existing structure could be reinforced to resist new vertical loads, it could not resist new lateral loads. The diagrid transfers lateral forces to the piers, which are supported by micropiles, and the system provides sufficient elastic deformation to relieve the stresses associated with thermal movement of the structure. At the terminal-side supports, multidirectional slide bearings allow lateral movement of the canopy relative to the existing structure.

The canopies were optimized with fabrication and construction feasibility in mind. While the truss chords appear to have gradually varying curvature, they are actually comprised of discrete constant-curvature sections, which are significantly less expensive to fabricate. The design and construction teams worked together to design connections that allowed construction to progress in stages during the overnight road closure time period. The truss splice connections have internal bolts that were rapidly installed and concealed with welded cover plates afterward.



David Camp HOK

The project's complex 3D modeling had to precisely plan each section component for quick construction, and the pieces had to be timed perfectly.

—Kari Berg



Matt Breidenthal HOK

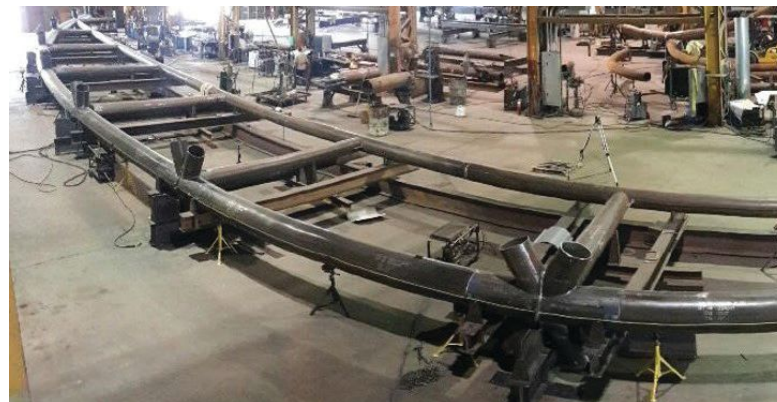

Mark Ejnes HOK



Miltivista-drone NSMS



Matt Breidenthal HOK



Matt Breidenthal HOK



Miltivista-drone NSMS

Throughout the project, the airport emphasized that construction of the canopies could not impact operational efficiency. This flipped the usual process on its head. Whereas in most cases logistics are secondary, in this case logistics drove the fabrication. The steel was detailed and sequenced to allow installation during limited roadway shutdowns between 10:00 p.m. and 4:00 a.m. The team used a 4D schedule to explain the sequence of construction associated with a 500-page logistics plan, and 3D printing and virtual reality applications were used to plan and monitor bearing movement during steel erection.

The biggest fabrication challenge was controlling steel movement due to welding and temperature changes. Steel fabricator Beck's fabrication of 38 identical trusses was successful thanks in large part to three key strategies. First, 50 tons of custom fixtures were built and welded to the floor to hold each truss' position during fabrication. This was crucial because the steel would move during the day as the shop heated up, and had to be frequently laser surveyed to monitor the geometry and adjust fabrication as needed. The second strategy involved cutting the HSS members with constantly varying miters that covered a range of 20° to 90° in a single pipe to minimize the amount of required weld material. Beck effectively had to "trick" the CNC machine's software to make some of these cuts. The alternative would have resulted in two or three times as much welding, which would have exacerbated steel distortion, and providing perfect cuts every time was critical to minimize welds and achieve identical behavior for each truss. And the third strategy? Weld everything flat. Rather than welding around the pipe, Beck kept the welding stationary in a flat position and rotated the steel, performing every weld identically on each truss assembly. This fabrication process involved trial and error but ultimately proved very successful.

The size and scale of the canopy trusses required the team to develop a system to expedite their on-site assembly. Manufactured 1,000 miles away in Beck's Lubbock, Texas, facility, the trusses arrived in five separate pieces. Shipping was easier than anticipated due to extensive planning; similar carriages were built for each piece and there were five different repeated arrangements mounted on the trucks. At the site, construction crews reassembled the trusses into three sections: a column piece connected to the pier, a mid-span piece, and a long-span assembly that fastened to the terminal. Each section took one evening to erect, and bolted connections allowed crews to quickly assemble the pieces. The team used telescopic crawler cranes that complied with FAA height regulations and made efficient use of pick lengths while minimizing point loads on the roadway, which is built over subterranean airport facilities. This successful collaboration returned the active seven-lane road to service each morning without any delay throughout two years of construction.

Owner

Hartsfield-Jackson Atlanta International Airport, Atlanta

General Contractor

New South | McCarthy | Synergy, Atlanta

Architect and Structural Engineer

HOK, St. Louis and Atlanta

Steel Team

Fabricator and Detailer

Beck Steel, Lubbock, Texas 

Erector

Derr & Isbell Construction, LLC, Roswell, Ga. 

Bender-Rollers

Bendco, Pasadena, Texas 
Chicago Metal Rolled Products, Chicago 

Aesthetically, the design bridges the urban setting with nature by incorporating elements of a bygone park from the area.

—Hollie Noveletsky

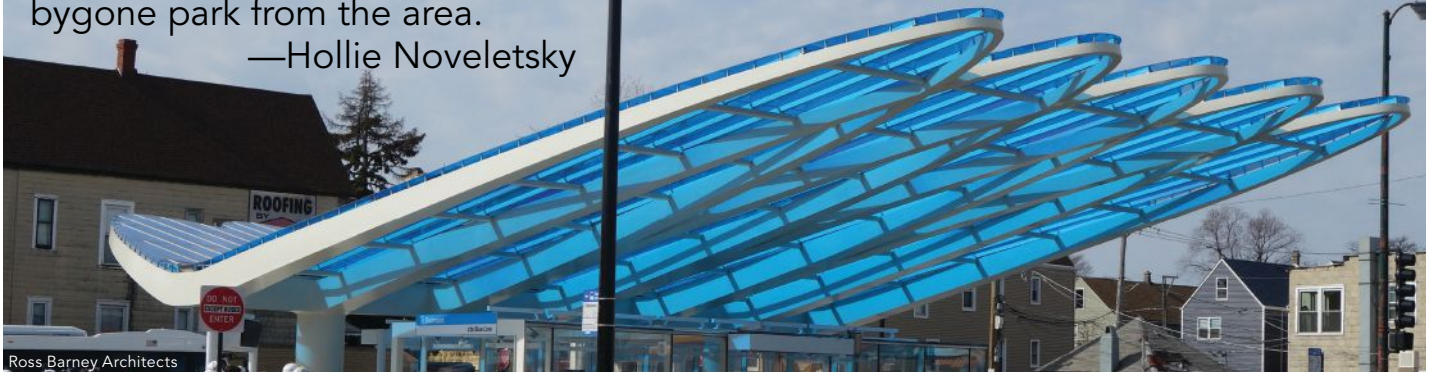

Ross Barney Architects

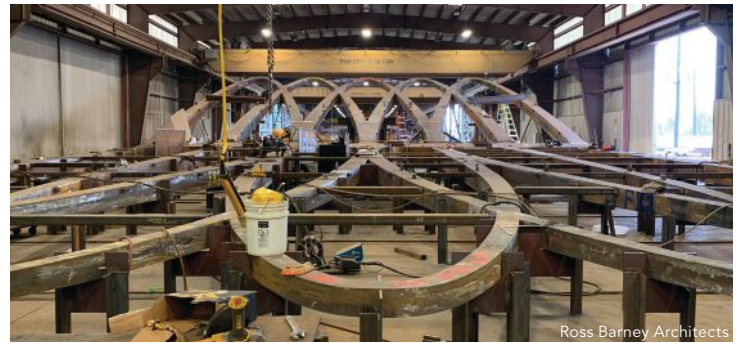
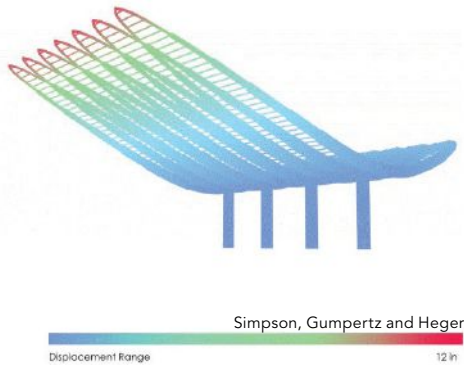

Ross Barney Architects

MERIT AWARD Sculptures/Art Installations/Non-Building Structures Belmont Gateway Canopy, Chicago

FIFTY YEARS AFTER BEING BUILT, the Belmont Blue Line Station is no longer a stylistic afterthought, but rather has been transformed into one of the most recognizable stations in the Chicago Transit Authority's (CTA) vast rail system.

As part of the Your New Blue program, CTA is reenvisioning and improving 14 Blue Line "L" train stations. The Belmont station had not been significantly modified since its construction in 1970, so upgrading the entrance provided an opportunity to improve the station's visual presence and create a community focal point within Chicago's Avondale neighborhood. The design, inspired by a waterfall from the bygone Olson Park, becomes "animated" when it rains as water cascades down the sloping canopy.

The canopy structure is formed by five petal-shaped, architecturally exposed structural steel (AESS) frames that cantilever 68 ft over the station's plaza and 28 ft in the other direction. AESS was chosen as a way to emphasize the overlapping outlines of the petals without adding unnecessary cladding. The primary framing members that form the outline of the petals are built-up rectangular tube sections that support hollow structural section (HSS) purlins that connect to the canopy's blue polycarbonate panels. The petals frame into a horizontal spine at the low point of the slope with custom castings that are supported on three 38-in. steel-encased concrete pipe columns concealing the drainage downspouts within the concrete.

The canopy's geometry required the primary structural framing members to be curved in one dimension, sloped in a second dimension, and tapered in the third dimension. Through creative design and by evaluating how the geometry influenced the strength

requirements, the project team was able to simplify fabrication. The primary HSS framing members efficiently resist biaxial and torsional stresses. Rectangular shapes were selected since they are more commonly used in the U.S. and are easier to connect. Plates were cut into trapezoids, curved, and welded together to form the curved tapering sections. Cast steel nodes were selected for the complicated moment connections where the petal loops meet the spine, as a means to adequately resist the forces, simplify construction, and meet aesthetic requirements.

The overall structural system includes the cantilevered canopy supported on three columns, and over 90% of the project's total weight (approximately 162 tons) is located in the canopies. A network of primary framing members provides stiffness to control deformations and is anchored to the ground with large concrete-filled steel columns that act as "tree trunks" to support the overlapping steel "branches" of the canopy.

To facilitate the connection at the geometrically complex regions where the petal loops intersect, built-up plate nodes were prefabricated to join the members and provide the desired aesthetic of member cleanly passing through each other. Prefabrication simplified erection and field welding and provided the means to achieve the AESS Category 3 requirements of visually seamless joints (for details on the various AESS categories, see "Maximum Exposure" in the November 2017 issue, available at www.modernsteel.com).

To transfer significant biaxial bending forces and torsion into the columns, accommodate the downspouts concealed within the columns, and provide access to place the concrete in the columns,



Ross Barney Architects



Ross Barney Architects



Ross Barney Architects

the design team worked closely with the cast steel designer and supplier, Cast Connex, to develop customized cast-steel connection nodes. Coordinating this design decision early in the schematic phase allowed the project team to evaluate the connection's ability to meet the required demands of the structure and provide confidence to the design team and CTA that the project vision would not be compromised within future phases of the job. In addition, minimizing the disruption to the surrounding area was important to CTA and the project team. A deep foundation system with small-diameter drilled piers was chosen to bypass existing below-grade structures and limit the effects on the adjacent street, active bus routes, and subgrade trains.

The steel castings found at the top of each column are each designed to connect the built-up sections forming the spine, petal canopies, and column below. The external form of the casting was designed to match the architectural language of adjacent structural steel, while the internal form was carefully designed to be as lightweight as possible while satisfying the structural loading, welded-joint considerations, and casting manufacturing constraints. Machined holes were also included through the casting to provide a port for the concrete to fill the column below and also provide a conduit for electrical and mechanical components.

This design-build project provided many opportunities for the design, casting, and fabrication teams to collaborate. Bringing these parties together early allowed the project team to work together to develop creative, efficient, and successful solutions. The design team used 3D and structural analysis models to coordinate and evaluate this complex structure, as well as to help facilitate information sharing. Architectural models developed in Rhino 3D were incorporated in the structural analysis model while customized software packages were used to automate portions of the analysis and evaluate numerous iterations and structural variables: the size of the AESS framing,

considering the varying cantilever lengths; framing plans (e.g., numbers of columns, petals, and intersecting petal nodes); plate thickness for the primary petal framing; column diameters and thicknesses; and the amount of welding required. The automated parametric structural analyses enabled the design team to analyze stresses and deflections for each combination of options and achieve the aesthetic goals while helping to minimize fabrication and erection costs.

The cantilevered boxed sections were fabricated out of 2-in. 50-ksi steel plate with mostly complete joint penetration (CJP) welds. AESS requirements reduced tolerances by half, minimized joint gaps, and stipulated that all welds had to be continuous with a uniform and smooth appearance within close visual proximity. The steel was fabricated and coated in Houston and shipped to Chicago in five sections on specialty heavy-haul trailers. Tekla was used to model the geometry, and fixtures were developed to ensure the correct layout was achieved so that a "drag and drop" fabrication process could be implemented.

Owner

Chicago Transit Authority, Chicago

Architect

Ross Barney Architects, Chicago

Structural Engineers

EXP, Chicago

Simpson, Gumpertz and Heger, Chicago

Steel Team

Fabricator and Detailer

King Fabrication, Houston



Erector and General Contractor

The Walsh Group, Chicago



Castings

Cast Connex Corporation



MERIT AWARD Sculptures/Art Installations/Non-Building Structures
 Little Charlotte Office Monumental Stair, Charlotte, N.C.

WHEN IT RECENTLY RELOCATED to a new high-rise in downtown Charlotte, N.C., architecture and engineering firm Little didn't just move into a new space; it created a new self-designed experience.

Designed by the firm itself, the flexible, attractive, sustainable space—which is pursuing LEED and WELL Silver certifications (with hopes of becoming the first Charlotte facility to achieve both certifications)—the new office occupies the 14th, 15th, and 16th floors of the building. And connecting all three floors is an open, internal staircase that acts as a focal point, an architectural center of gravity.

This monumental centerpiece, however, isn't just any connecting stair. Little used its engineering, design, and architectural expertise to create a structure that not only provides a destination for ideas, culture, experience, story, work, and interaction, but also an unexpected visual statement—starting at the top.

Instead of being traditionally anchored and reinforced at the lowest level, which would disturb existing tenants on the 13th floor below, this 15-ton stair hangs from a four-pronged, structural mast anchored to the underside of the building's 17th floor. Ensuring structural reliability was a challenge for the design team, which knew it did not want to add significant strengthening to the existing building structure. Using the existing build-

ing as it was originally designed reduced the carbon footprint of the renovation while also making it more cost-effective. With the stair connecting three of Little's floors, the team was able to remove the mildly reinforced concrete slab and a 21-in. mildly reinforced concrete beam at two levels, which totaled 28 tons of concrete—more weight than the stair itself.

The four-pronged structural mast distributes the load of the stair to the underside of the 17th floor beams with bolted steel channels and transfers some of the load to the 16th and 15th floors, allowing the existing structure to adequately carry the appropriate load as required by code. Approximately 55% of the dead and live loads are carried by the 17th floor, while the 16th and 15th floors support the remainder of the load transferred from the inside HSS14x4 stringers. The mast connection to the 17th floor is accomplished by four 2¼-in.-diameter pins, and was used to eliminate the transfer of any moment into the existing structure while also complementing the rawness of the design.

The main stair structure was designed to give the impression that the stair "floats." Two HSS10x6 outriggers are cantilevered from the steel mast at each level supporting each HSS14x4 stringer, and an HSS14x4 outrigger cantilevers from the mast to support the landing. The main HSS14x4 stringer runs along the inside edge of the stair directly under the inside railing and is



Ricardo Pulido

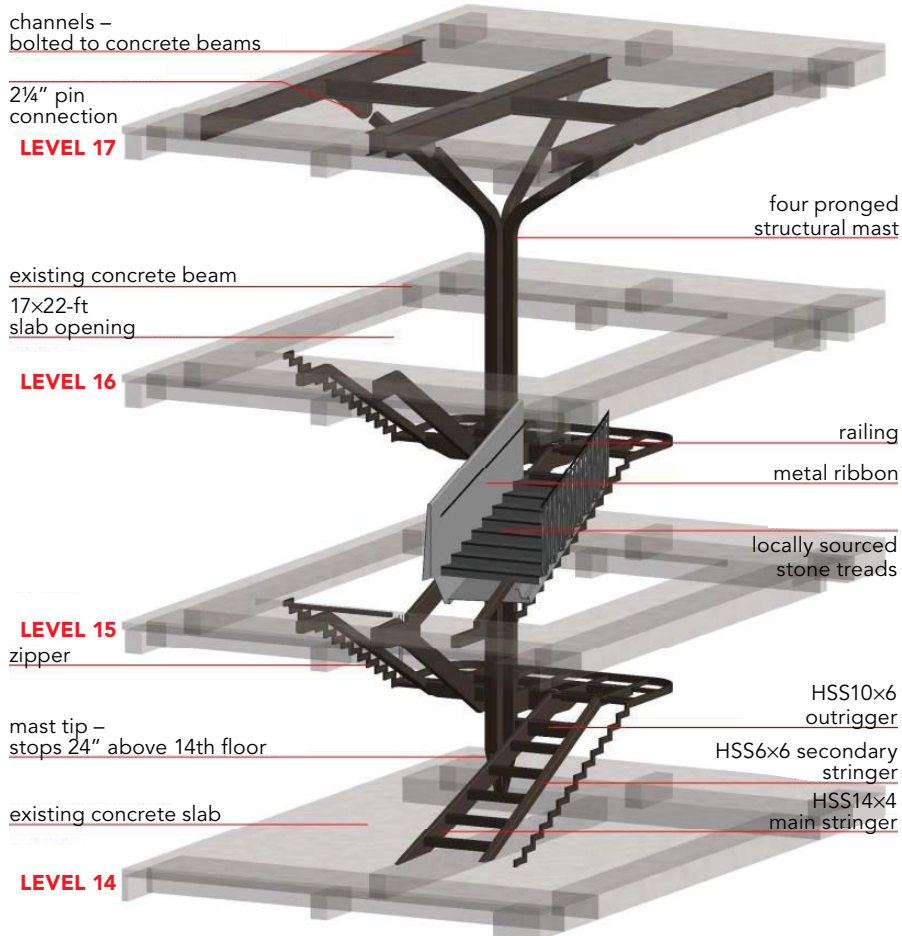

supported by the 15th and 16th floors as well as the HSS10×6 outriggers at the intermediate landings, which frame back to the center mast. A secondary HSS6×6 stringer runs along the stair approximately 2 ft, 4 in. from the outside edge of the stair. The architects requested that the edge of the stair treads be exposed steel and termed this element the “zipper,” which in turn supports the outside railing. The design of the stair also included checking step live loading with live load on only half the stair as well as only on the landings to verify stresses and movement. Differential deflections of the 15th and 16th floor structural members were also checked, as altering these movements changed the amount of load supported by the 17th floor.

Even with diligent planning from both the engineering and design team, the stair execution did not come without its challenges. One obstacle was the limited size of the building’s freight elevator, which in turn limited the size of elements and assemblies that could be transported to the space. The solution? Construct the stair at the fabricator’s (C.M. Steel) shop and then cut it into 42 pieces to be delivered and reconnected on-site. Once in the space, the stair was pieced back together using full-penetration welds. The construction sequence took advantage of the existing floor by installing the hanger framework on the underside of the 17th floor prior to cutting the new holes in levels 16 and 15.

The team also had to take care not to damage rebar and post-tensioned (PT) cables while adding the connections to

the 17th floor and attaching the stringers to the 15th and 16th floors (bolted to the PT girders). All reinforcement and PT cables were located by use of X-ray and ground-penetrating radar prior to drilling.

While the structural integrity of the stair was important, so was its architectural design. A winding ribbon of structural steel creates a finished backbone rendered in white and contrasts with the rawness of the steel that it threads together. All exposed steel was left to patina for several months in the field, and was later rubbed with a protective bee’s wax (selected to meet the WELL requirements for the space).

The materials chosen for the stair were critical to how it would invite users—the more “raw” the better. Bolted connections, welds, bends, and cuts express the inherent beauty of the materials in terms of how they look, feel, and sound. To keep with this intentional rawness, the visible welds were only lightly ground, and the railing surrounding the stairway mimics the shading of architectural sketches.

Owner, Architect, and Structural Engineer

Little Diversified Architectural Consulting, Charlotte, N.C.

General Contractor

DPR Construction, Charlotte

Steel Fabricator, Erector, and Detailer

C.M. Steel, Inc., York, S.C. 

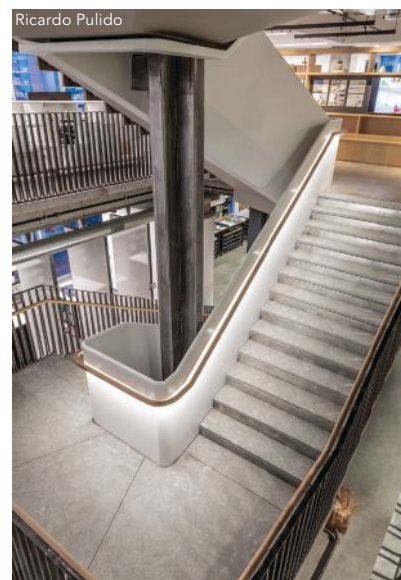

Steel provides efficiency at all levels
of a new hotel in the center of
the City of Brotherly Love.

Upscale and Urbane

BY LEA COSENZA AND
ALBERT MEYER, PE

opposite page: Hyatt Centric Philadelphia is the latest of the hotel chain's smaller, upscale, urban core-focused properties.

below: The 175,000-sq.-ft, 13-story hotel houses 332 guest rooms, 40 modern executive suites, and amenity spaces.



SOMETIMES, IT'S GOOD to be in the heart of it all.

This is the mindset behind Hyatt Centric, the famed hotel company's smaller, upscale, urban core-focused line of properties.

With nearly 40 locations around the globe and more than 20 in the U.S., the latest Hyatt Centric is nearly complete in Philadelphia, rising a block from historic Rittenhouse Square in the heart of the city's premier dining and retail district.

The 175,000-sq.-ft, 13-story hotel houses 332 guest rooms, 40 modern executive suites, a street-level and an upper-floor restaurant, a fitness center, event spaces, meeting facilities, lounges, and a small green roof. There are also two levels of underground parking with stackers, including spaces for 220 cars and 32 bicycles.

Framing Flexibility

In determining the structural system, structural engineer the Harman Group considered multiple options, including two-way flat plate concrete. Ultimately, lower cost, increased flexibility, and reduced construction time led to the choice of a steel frame.

The building incorporates 1,340 tons of steel in all. The overall width-to-length ratio of the hotel's footprint (57 ft by 249 ft) necessitated the use of steel braced frames to provide lateral resistance in both directions. These frames—using HSS12x8 and HSS8x8 for the bracing elements, W12 columns, and W10 gravity members—are located around elevator shafts and stairs. At the center of the building, the elevator and stair openings cut off direct lateral load transfer from the diaphragm to these frames. Located below the plank, L4x4x3/4 drag struts in an "X" configuration drag the load into the frames. In addition, two large transfer girders at the third floor, one a W40x503 and the other a W40x593, provide a large, column-free area for the second-floor ballroom and also support hanging partitions.



Lea Cosenza (lcosenza@harmangroup.com) is an associate and the director of The Harman Group's New York office. **Albert Meyer (ameyer@harmangroup.com)** is an associate and senior project engineer with The Harman Group's Philadelphia office.

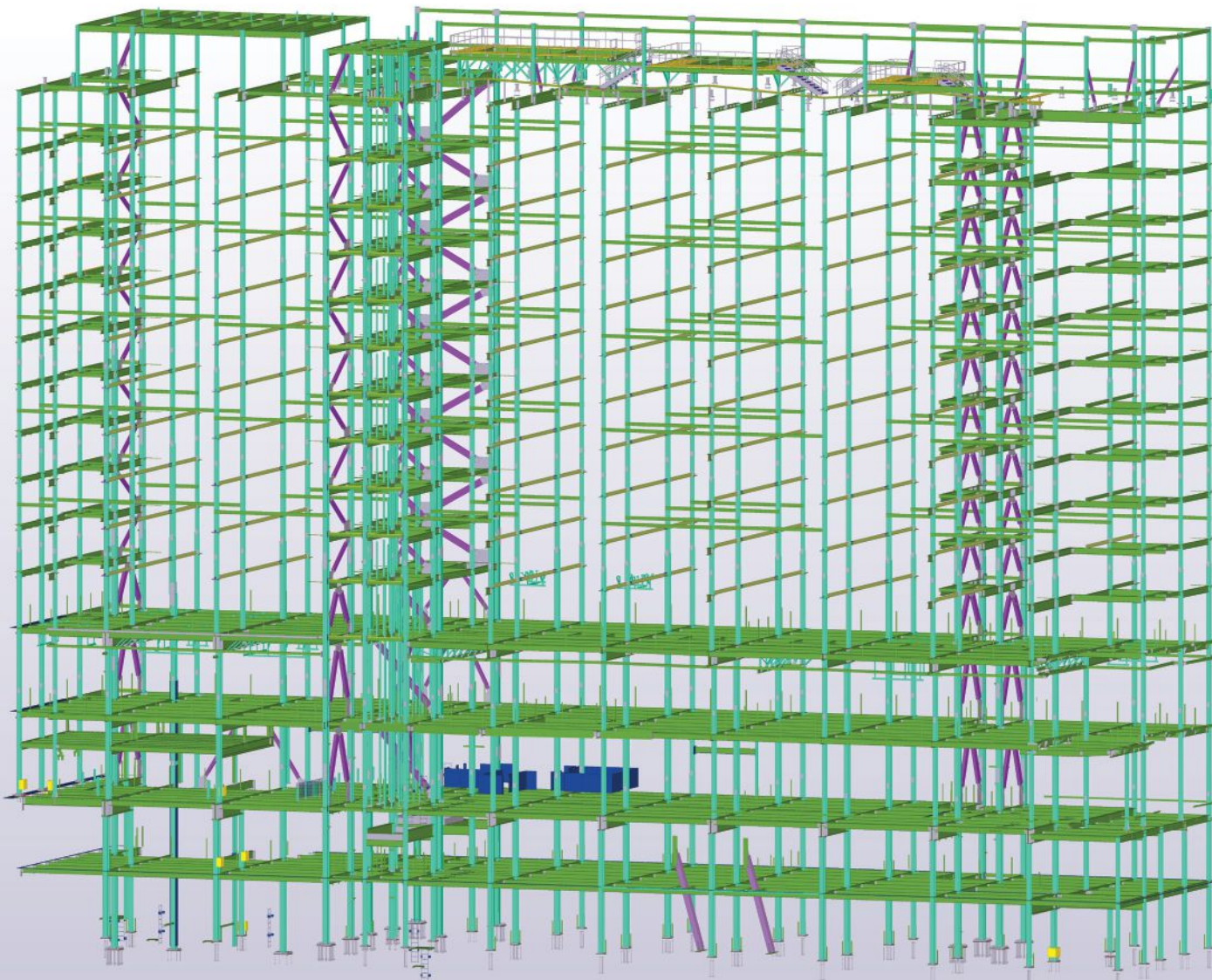

Berlin Steel

The overall width-to-length ratio of the hotel's footprint (57 ft by 249 ft) necessitated the use of steel braced frames to provide lateral resistance in both directions. These frames—using HSS12×8 and HSS8×8 for the bracing elements, W12 columns, and W10 gravity members—are located around elevator shafts and stairs.

The basement level up through the third floor uses composite slab on metal deck supported on wide-flange beams and girders, and columns are transferred at the third floor on W36×210 transfer girders to allow for an efficient column layout in the parking levels. Hung spans are used for the third-floor transfer girders, which run over and cantilever past the supporting column, with the girder beyond connecting to the cantilevered end of the transfer girder. This geometry, which effectively makes the primary span of the transfer the back span for a cantilever portion, reduces the magnitude of the positive moment in the transfer girder, allowing for smaller members. At the roof level, wide-flange beams and girders, ranging from W18s to W24s, support the precast plank and facilitate flexibility in locating and supporting the screen wall posts (HSS8×8×½), which are located at mid-span of each bay, as well as the dunnage supports for heavy mechanical equipment.

Creating Clearance

For the floor system at the hotel room levels, it was imperative for the design team to minimize floor depth at the hotel room levels in order to achieve the required clear height and allow maximum room for MEP systems. The typical hotel level floor-to-floor height is 10 ft and the finished ceiling height in majority of the hotel room spaces outside of bathroom area is 9 ft, 4 in., with the underside of precast plank serving as the ceiling. The more common system of composite metal deck supported by steel beams was not ideal for this project as it didn't easily facilitate the required clearance. As such, the design team turned to the Girder-Slab system to frame the floors at the hotel room levels. In this system, elements known as D-BEAM girders act compositely with precast hollow core plank, providing an overall floor structure depth of 8 in. nominal. An 8-in. precast



Harman Group

above: The typical hotel level floor-to-floor height is 10 ft and the finished ceiling height in majority of the hotel room spaces outside of bathroom area is 9 ft, 4 in., with the underside of precast plank serving as the finished ceiling.

right: A detail of a plank bearing on a Girder-Slab D-BEAM.

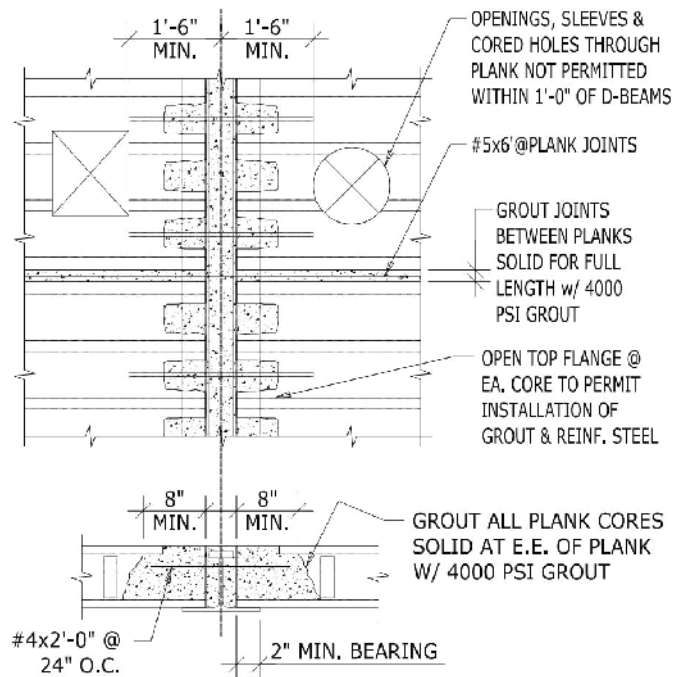

plank spans between the D-BEAM girders and is grouted solid with reinforcing bars at the girders to make the system composite. The D-BEAM girders typically frame from column to column, but at the center of the building they frame to tree beams that match the girder profile. A tree beam is a segment of beam that is nearly identical in profile to the D-BEAM without web openings. These tree beams are cantilevered from the columns to allow for longer spans using the same girder size.

All Girder-Slab system components are fabricated off-site and shoring for the floor structure isn't required as it would be for a flat-plate concrete slab, yet the system maintains an overall thickness like a flat-plate concrete slab, thus improving constructability and saving on construction time. For this project, the tree beams were welded to the columns in the shop, so bolted connections could then be used in the field to allow for ease of erection. Connection design for the Girder-Slab components, as well as the entire framing system, was performed by Harman's construction engineering group, which allowed for a more efficient transition from design to construction. Responses to questions between the connection design engineer and the engineer of record (EOR) can often take up to a week when going through the typical channels of the design and construction team—but this

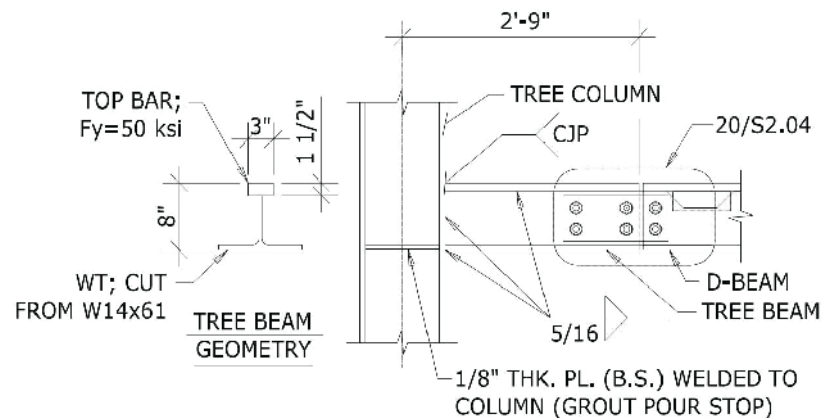

A tree-beam-to-column connection.



Harman Group



Harman Group

above and left: The building incorporates 1,340 tons of structural steel in all.

.....
time frame can often be reduced to less than an hour where the connection design engineer is in the same office as the EOR, as was demonstrated by this project.

Stacks and Storage Tanks

The City of Philadelphia requires that storm water be managed with on-site basins, which then meter water into the storm sewer system. However, the building occupies the entire footprint of the site, thus preventing these basins from being placed below grade. As such, a steel platform was designed to support steel storm water storage tanks that were suspended below the second floor level above the entry drive to the car elevators. Similar to a mezzanine, this galvanized steel platform is hung from the underside of the second-floor structure, using L6x6 hangers, so that drive lanes to the car elevators could remain clear; posts from below would have conflicted with the drive lanes.

The steel framing at the below-grade parking levels, which is accessed via three car elevators, is similar to a traditional slab-on-metal deck for typical floor levels except that,

due to exposure to deicing salts, the metal deck is designed as sacrificial and the reinforcing steel in the slab is designed such that the deck serves only as a form for the concrete. A soon-to-be-installed steel-framed vehicle stacker system will allow for the maximum number of cars within these two levels, and loading for the system was accounted for during design to allow for flexibility in location of posts. The parking stacker system was anticipated to typically be supported by directly connecting to the primary building columns and perimeter basement wall, but it was expected that some locations would be required to be posted down to the floor structure in certain locations. The exact layout of the parking stacker system was not known at the time the primary structure was being designed and documented. As such, anticipated loading and connection points were assumed and applied to the structure to provide an economical primary structure design with flexibility of the parking stacker system layout without actually knowing what the final configuration and loading would be. Where the stacker system layout did not allow connections to primary building columns or basement walls, supports posts could be placed at virtually any point on the foundation mat surface, the top of which is used as the lowest parking level. This mat foundation was designed by WZG Structural Consulting Engineers, which also assisted with shop drawing review, to fulfill the project's Minority and Women-owned Business Enterprises requirement.

Once completed later this year, the Hyatt Centric Philadelphia will be a prime addition to the many major hotel openings in Philadelphia over the last few years. And it will be smack-dab in the middle of all of them. ■

Owner and Developer

Hyatt Hotels Corporation, Chicago

General Contractor

Clemens Construction Company, Philadelphia

Architect

DAS Architects, Philadelphia

Structural Engineers

The Harman Group, Philadelphia (also Connection Designer)
WZG Structural Consulting Engineers, Inc., Limerick, Pa.

Steel Fabricator, Erector, and Detailer

The Berlin Steel Construction Company, West Chester, Pa.



Over the Top Pallet Wrap

The industry's toughest, most weather resistant pallet wrapping!

Call or email us your inquiry!

St. Louis Screw & Bolt

sales@stlouisscrewbolt.com

800-237-7059

Protects labels & custom tagging!

QUICKFRAMES

2015-2019

INSTALLED

45K

RETURNS

00

VS

QUICKFRAMES = QUALITY

QuickFrames.us

480-464-1500

California Dreaming

INTERVIEW BY GEOFF WEISENBERGER



Geoff Weisenberger (weisenberger@aisc.org) is senior editor of *Modern Steel Construction*. **Nicholas Zacher** is a project manager with TrueNorth Steel.

AN ADDITION to Long Beach, California's Aquarium of the Pacific undulates like the sea itself.

The expansion, called Pacific Visions, opened in 2019 and houses an immersive theater, additional special exhibition and art galleries, and increased space for live animal exhibits within a curvaceous façade clad with a grid of privacy glass of various shades. It used 350 tons of structural steel and 4,831 connection bolts to hold it all together—all delivered from Minnesota in 30 truckloads.

We talked with Nicholas Zacher, a TrueNorth Steel project manager—the project's fabricator—about what it was like detailing and fabricating a project with virtually no right angles.

It sounds like the building isn't your typical "box" design.

Definitely not. There are minimal 90° angles in the design. This building is not a perfect oval or a circle but it is curved. The exterior gives the illusion of curved steel, yet we did not bend any steel in the superstructure or hire any external specialty steel contractors. The structure was completed primarily with straight wide-flange components set on a skew by the TrueNorth Steel drafting team.

So why wasn't curved steel used, given the building's clearly curved form?

Initially, we considered bringing in a specialty partner to curve the steel, which we've done before successfully. But in this case, while following the skewed connections provided by the design team, we were able to create a solution that met the desired aesthetic appeal and budget without the need for curving. That said, once we committed to the approach we wanted to take, it meant we were going to basically custom fit every beam into this nonstandard shape, all the way around.

A northern fabricator discusses the challenges and solutions of fabricating an aquarium addition in a SoCal locale.



All images: TrueNorth Steel

above: Pacific Visions is a new expansion to Long Beach's Aquarium of the Pacific.

right: Right angles are virtually nonexistent in the framing, which achieves a curved aesthetic without curved steel.

.....

Can you elaborate on how you achieved a curved look without actually curving any steel?

We've done many complicated geometry projects, but none that encompass a radius structure with no curved steel. The team took radius dimensions and installed all beam-to-beam connections to columns to create the radius. Stadiums have a radius component, but we haven't seen one made of straight connecting pieces—at least not to this extent. A lot of stadiums are oval or at least a standard "shape." This project is what we call multi-axes. It is not a constant circle. It's concave and convex as you work your way around the building. When you marry steel beams with curves, you find yourself seeking the expertise of your design team. And that's what we did. Our solution meant we had to custom fit every single beam into this non-standard shape. The only square design of this project was the elevator. Even the stairs were tied into radius requirements. Getting deep into the



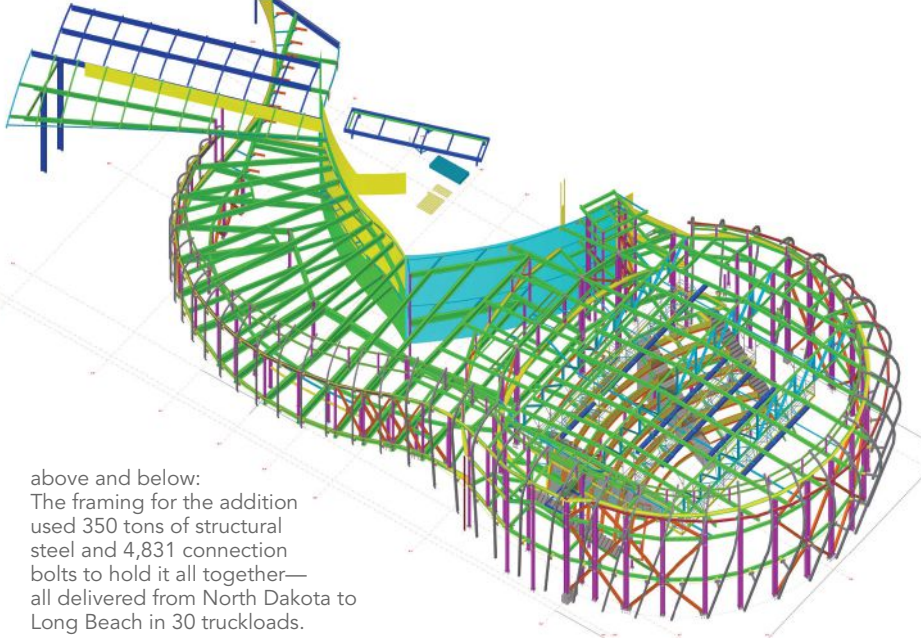

above and below:
The framing for the addition used 350 tons of structural steel and 4,831 connection bolts to hold it all together—all delivered from North Dakota to Long Beach in 30 truckloads.

details prior to modeling was key to getting the 3D model dialed in correctly prior to printing drawings.

When it comes to the theater seating, it is framed with ¼-in. and ⅜-in. steel plate on steel rakers with form deck infill. This was a complex system to install as the riser plate doubled as the pour stop, so hitting elevations was critical.

Given the geometry, I'm guessing connections were a challenge.

The curvature of the building definitely created another unique problem to solve in terms of the connections. The team at the general contractor, Clark Construction, collaborated with our team on a consistent basis to make sure we were all on the same page. We had to make a structural steel connection to a glass façade that had no adjustability. Tie-in plates had an agreed-upon tie in advance. This made it tough because the outrigger connections were square. All of them had an “X,” “Y,” and “Z” axis that had to be coordinated.

There were 96 unique outrigger connections in all. We got them set to where we believed to be right based on the information provided, but the on-site tolerances didn't agree. These were galvanized hollow structural sections (HSS) with shop-welded plate that encompassed variations in all three axes, and they had to be installed with a variation of ¼ in. maximum in the X and Z axes and ½ in. in the Y axis. We knew the variations would exist but we did not know exactly *how much* variation would exist until the building was plumb and lined up in the field. The major contributor here is heat expansion. Depending on the time of day the surveys were shot, we would see up to ⅛ in. in variation from survey to survey. Luckily, no re-fabrication was needed, but we did have to move a handful of plates and provide a few shims. Clark performed a 3D scan of the building and our drafting team extrapolated these points in space, which drove the final locations of the glass tie in outriggers, then we made the required adjustments. At the end of the day, success boils down to the partners you have on the project and your working relationship, and this was a perfect example.

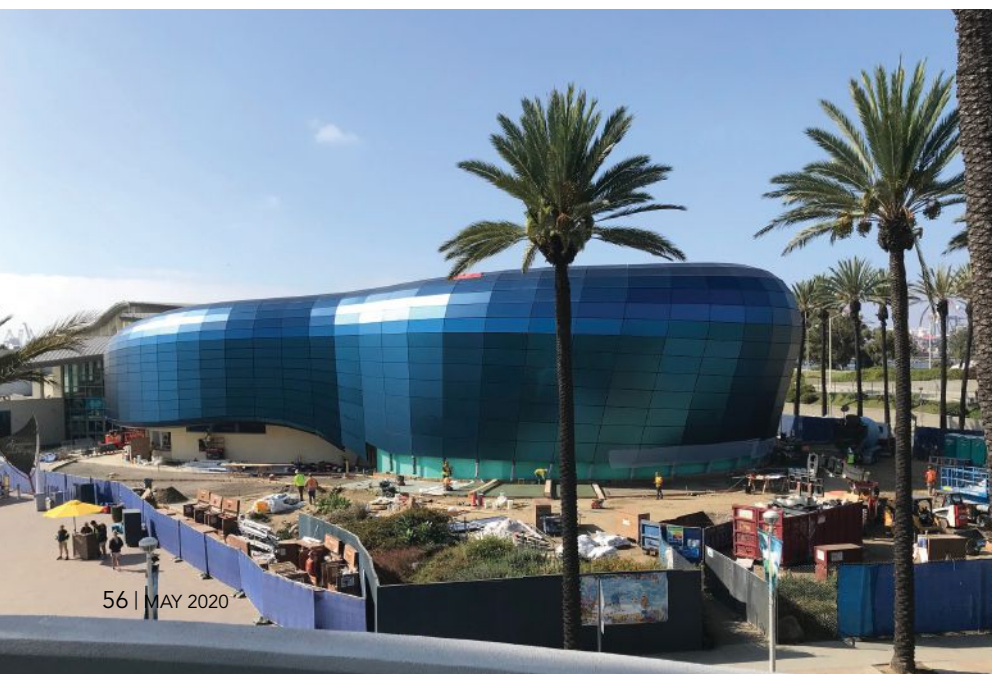

left: The addition is clad in a curvaceous grid of privacy glass of various shades.

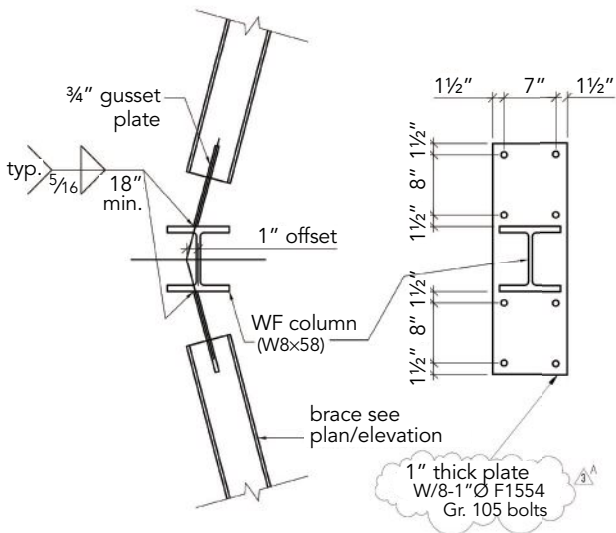

left: An example connection detail for the steel framing. All steel for the theater superstructure was detailed, fabricated, and erected on a radius with straight connecting members.

below: The theater seating is framed with 1/4-in. and 3/8-in. steel plate on steel rakers with form deck infill, a complex system to install as the riser plate doubled as the pour stop.

How did a fabricator in North Dakota get involved with a project in Greater Los Angeles? Were there any challenges with transportation and erection?

We have a good relationship with Clark Construction from previous projects. As for transportation, as always, winter delays are expected in the northern states but fall on deaf ears in Southern California! Lay-down area was enough for one truck's worth of material. That was it. So just-in-time deliveries were critical, as was the need to provide smaller manageable sequences.

In the end, having accurate information at the onset and consistent on-site and off-site team collaboration with partners, especially Clark, is what drove the success of the project. And thanks to our in-house detailing expertise, our drafters had the vision and ability to draw the final requirements for what was a relatively new type of design for us.

For an infographic on the Aquarium of the Pacific, see the Project Extras section at www.modernsteel.com.

Owner

Aquarium of the Pacific, Long Beach, Calif.

General Contractor

Clark Construction

Architect

EHDD Architecture, San Francisco

Structural Engineer

Wheeler and Gray Consulting Engineers, Pasadena, Calif.

Steel Team

Steel Fabricator and Detailer

TrueNorth Steel, Fargo, N.D. 

Steel Erector

Bragg Crane and Rigging Co.,  Long Beach

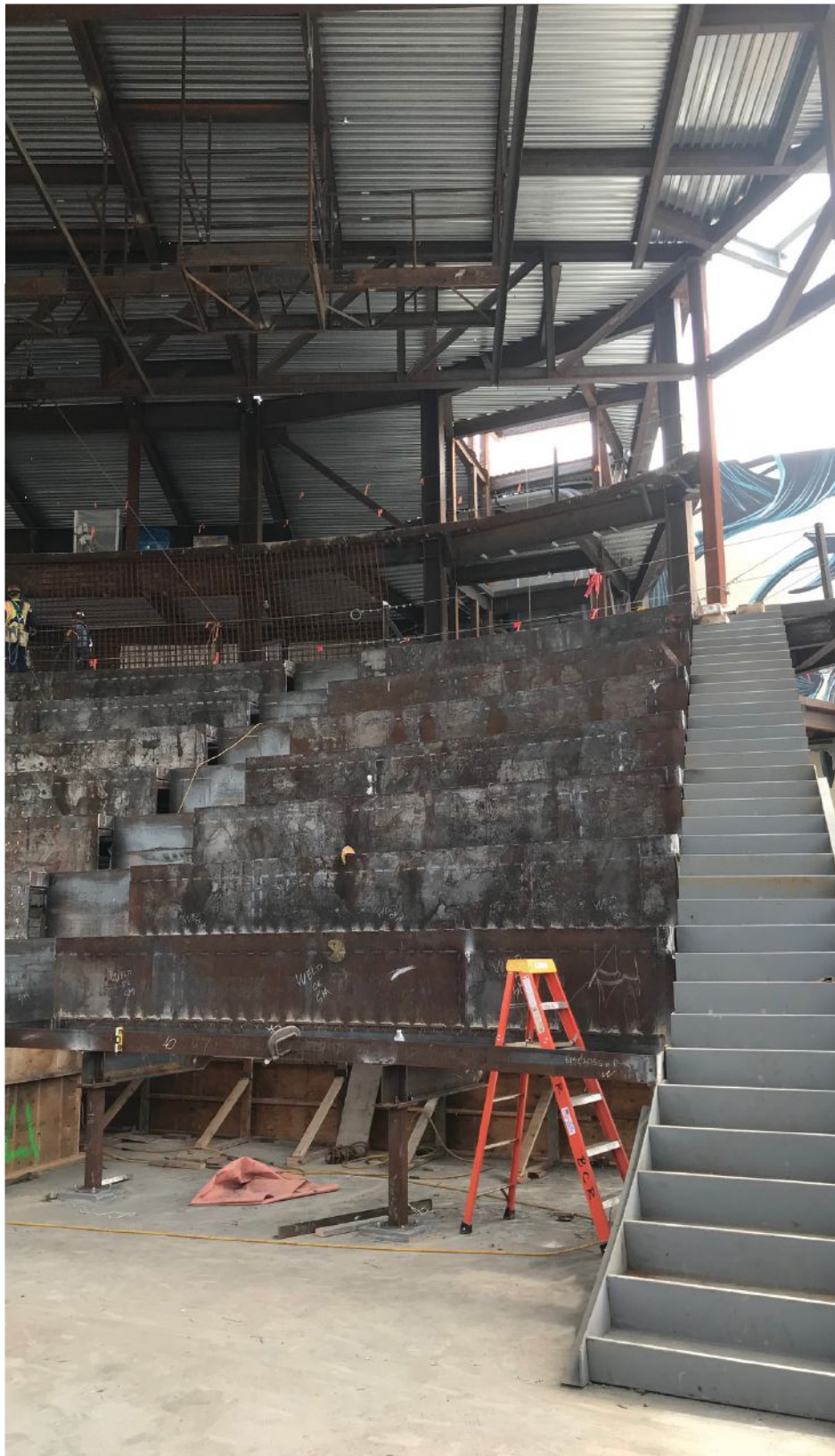

A new report showcases the development of economical and efficient shallow press brake-formed tub girder bridges.

Tub Time

BY KARL E. BARTH, PH.D, GREGORY K. MICHAELSON, PH.D,
ROBERT M. TENNANT, AND ADAM D. ROH



Barry Hatfield II, WVDOT

IN 2009, the Federal Highway Administration (FHWA) challenged the North American steel industry to develop a “cost-effective short-span steel bridge with modular components, which could be placed into the mainstream and meet the needs of today’s bridge owners, including accelerated bridge construction (ABC).”

And the Short Span Steel Bridge Alliance (SSSBA) delivered. SSSBA is a group of bridge and buried soil structure industry leaders who have joined together to provide educational information on the design and construction of short-span steel bridges in installations up to 140 ft in length. The group took

up the challenge and initiated research into an alternative to prestressed concrete beams for short-span bridge applications. SSSBA’s technical working group—consisting of 30 organizations including the American Iron and Steel Institute (AISI), AISC’s National Steel Bridge Alliance (NSBA), National Association of County Engineers, steel bridge fabricators, university faculty members, steel manufacturers, government organizations, and bridge owners—developed a solution: a modular, shallow press brake-formed steel tub girder (PBTG). The girder’s design is shown in Figure 1.

The comprehensive research, development, and proof-of-concept efforts were led by West Virginia University and Marshall University. And the complete research study is available in a six-volume report, available at www.shortspansteelbridges.org. Following are brief summaries of each volume.

Volume I—Development and Feasibility Assessment of Shallow Press-Brake-Formed Steel Tub Girders for Short Span Bridge Applications. Design of the modular tub girder system was completed in two stages. First, a spreadsheet was developed to compute the section properties of any tub girder

Fig. 1. A model of a composite press brake-formed tub girder (PBTG).

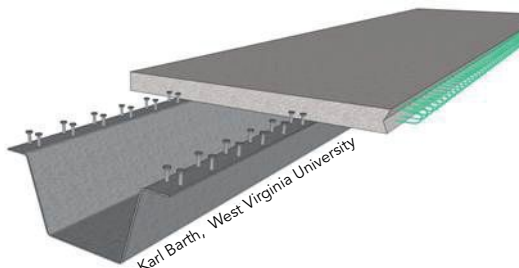



opposite page and above: Installing the Fourteen Mile Bridge in Lincoln County (District 2) near East Lynn, W.V., a PBTG bridge. Comprehensive research, development, and proof-of-concept efforts for the PBTG design were led by West Virginia University and Marshall University.

configuration. Next, design iterations were performed based on conservative estimates of press brake tub girder capacity, limiting the capacity of the composite girders to the yield moment.

In order to verify the performance and capacity of this newly developed modular tub girder, physical testing was conducted at the Major Units Laboratory at West Virginia University. Flexural testing was conducted on simply supported composite and non-composite press brake tub girder specimens in three-point bending. The test load was applied at mid-span using a servo-hydraulic actuator which was mounted to a large structural reaction frame.

Next, two separate analytical tools using nonlinear finite element methods and strain-compatibility procedures were developed and benchmarked against experimental data. Results demonstrate the proposed system is an economically competitive alternative for the short span bridge market.

Volume II—Experimental Evaluation of Non-Composite Shallow Press-Brake-Formed Steel Tub Girders. The originally proposed system consisted of a reinforced concrete deck cast on the girder in the fabrication shop, forming a composite modular unit



Karl E. Barth (karl.barth@mail.wvu.edu) is the Jack H. Samples Distinguished Professor in the Department of Civil and Environmental Engineering at West Virginia University. **Gregory K. Michaelson** (michaelson@marshall.edu) is an assistant professor in the Department of Civil Engineering at Marshall University. **Robert M. Tennant** (rmtennant@mix.wvu.edu) is a PhD Student in the Department of Civil and Environmental Engineering at West Virginia University. **Adam D. Roh** (adroh@mix.wvu.edu) is a Masters Student in the Department of Civil and Environmental Engineering at West Virginia University.



The Amish Sawmill Bridge in Buchanan County, Iowa, was the first bridge designed, constructed, and opened to traffic using the PBTG concept.

SSSBA 7

once cured. The composite unit would then be shipped to the construction site to be installed. However, the option of implementing a cast-in-place deck was also explored. A critical design stage for these girders occurs during the pouring of the concrete deck, when the non-composite steel section must support the construction load, including the weight of the wet concrete.

Flexural testing was performed on two non-composite specimens to assess the ultimate capacity of the system. Both specimens failed from global lateral torsional buckling. It was also observed that the non-composite girders may be susceptible to torsional amplification due to geometric imperfections. External bracing configurations, which are not required with modular composite units, were recommended for cast-in-place construction. Available system capacity equations agreed with experimental results.

Volume III—Evaluation of Modular Press-Brake-Formed Tub Girders with UHPC Joints. The use of prefabricated bridge elements and systems has led to the recognition that durable connections are the key components in this type of construction. Ultra-high-performance concrete (UHPC), which is a steel fiber reinforced, Portland cement-based product with advantageous fresh and hardened properties, is used for creating robust connections between the prefabricated components. The use of the UHPC as a joint media is becoming more popular during bridge construction.

A model of a bridge system comprised of two composite modular PBTGs connected with a UHPC joint was proposed and evaluated. This was accomplished by constructing two modular units and joining them with a UHPC joint. The system was then fatigue loaded simulating 75-year rural traffic conditions. Experimental results were used to evaluate the reliability of the longitudinal UHPC joint in a composite tub girder system. Results demonstrate the performance of the joint was consistent throughout the test.

Volume IV—Field Performance Assessment of Press-Brake-Formed Steel Tub Girder Superstructures. After several years of lab testing at West Virginia University, the Amish Sawmill Bridge in Buchanan County, Iowa, was the first bridge designed, constructed, and opened to traffic using the PBTG concept. Upon the completion of this bridge, researchers from West Virginia University and Marshall University traveled to Iowa to perform a live load field test.

Live load distribution factors (LLDFs) calculated for each method were nearly identical and displayed how the composite system transferred the various loading between the four girders. Based on the results and conclusions drawn from this research, PBTG bridges exhibit consistent performance and are a practical option in the short-span bridge industry, especially when paired with ABC methods.

Volume V—Fatigue Performance of Uncoated and Galvanized Composite Press-Brake-Formed Tub Girders. The cold-bending of the steel plate into the desired tub girder shape creates residual stresses in the bends of the girder. It was unknown if the high heat of galvanization would affect the residual stresses in the bends of the tub girder.

Laboratory testing was conducted to determine if hot-dip galvanization affects the fatigue performance of a cold-bent shallow PBTG. Two composite steel tub girders were constructed, one composed of an uncoated steel tub and the other composed of a galvanized steel tub. The composite system was fatigue loaded simulating a 75-year life in a rural environment. Experimental results were used to evaluate any difference in the performance of the different steels used in the composite tub girder system. Results demonstrated galvanization did not influence the fatigue performance of the girders and is therefore the recommended means of corrosion protection.



SSSBA

Volume VI—Field Performance and Rating Evaluation of a Modular Press-Brake-Formed Steel Tub Girder with a Steel Sandwich Plate Deck. The Cannelville Road Bridge in Muskingum County, Ohio, is the second PBTG bridge to be installed in the field. The structure is composed of two modular tub girder and sandwich plate steel (SPS) deck units that were constructed off-site and erected using ABC methods. The main superstructure elements of this bridge were installed in just over 22 minutes. The research team also conducted live load field testing of this structure. (For more on this project, see its description in the 2018 Prize Bridge Awards coverage in the June 2018 issue. And be sure to see the upcoming July 2020 issue, which will feature this year's Prize Bridge Award winners. All issues of *Modern Steel Construction* are available at www.modernsteel.com.)

The results of the live load field test and finite element analysis were used to generate bottom flange bending stress, LLDFs, and interior and exterior girder ratings. These values, experimental and analytical, were then compared with equivalent LLDFs, and live-load girder ratings were computed referencing AASHTO LRFD *Specifications*. The results of this testing demonstrated current AASHTO LRFD *Specifications* for analyzing shallow PBTGs are conservative, with field performance exceeding calculated performance.

In addition to high performance, tub girders are practical in ABC applications and compatible with various deck designs as modular units. With a growing demand and need for rapid infrastructure replacement, shallow PBTGs have proven to be an effective application in response to the growing industry demand. They are cost-effective, can remain in service for up to 100 years, and can be installed in far less time than conventional bridges due to the precast nature of the composite deck. ■

above and below: The Cannelville Road Bridge in Muskingum County, Ohio, is the second press brake-formed steel tub girder bridge to be installed. The bridge is a 2018 NSBA Prize Bridge Award winner.



SSSBA

MANUAL Printed Manual Companion Now Available

Your *Manual* now has a companion.

The v15.1 *Companion to the AISC Steel Construction Manual* is now available as a printed two-volume set. Developed by industry leaders in the AISC Committee on Manuals, the *Companion* is the perfect complement to your 15th Edition *Manual*. It includes more than 1,600 pages of examples and tables that illustrate how to apply the provisions of the 2016 *Specification for Structural Steel Buildings* (ANSI/AISC 360) and the *Manual* for designing members, connections, and structural systems.

For ease of use, the *Companion* is separated into the following volumes:

Volume 1—Design Examples includes detailed examples covering the provisions of the *Specification*. Guidance is also provided on how to apply the tables of the *Manual* to simplify the design process. Complete connection design examples are provided for the most common shear, moment, axial, and bracing connections. Volume 1 also has an example that covers the step-by-step procedure for load determination and member selection of a four-story building.

Volume 2—Design Tables includes many design tables that expand on what's included in the *Manual*. New for the *Manual* is an all-in-one member design—"Super Table"—for determining the available strength for W-shapes subject to axial, shear, flexure, and combined forces (Table 6-2). Volume 2 of the *Companion* includes this same style of table for ASTM A913 (Grades 65 and 70) W-shapes, and HSS members of both ASTM A500 Gr. C and ASTM A1085. Volume 2 also has compression tables for composite HSS columns and the combined loading table for W-shapes, both of which last appeared in the 14th Edition *Manual*. There is also a plastic section modulus table for coped W-shapes.

The printed *Companion* will quickly become a go-to reference in your bookcase. It is also a helpful tool for training new engineers on steel design. For more information on this resource and other useful resources provided by AISC, visit aisc.org/manualresources. And visit aisc.org/specifications to access the *Manual*, *Specification*, and other AISC publications.

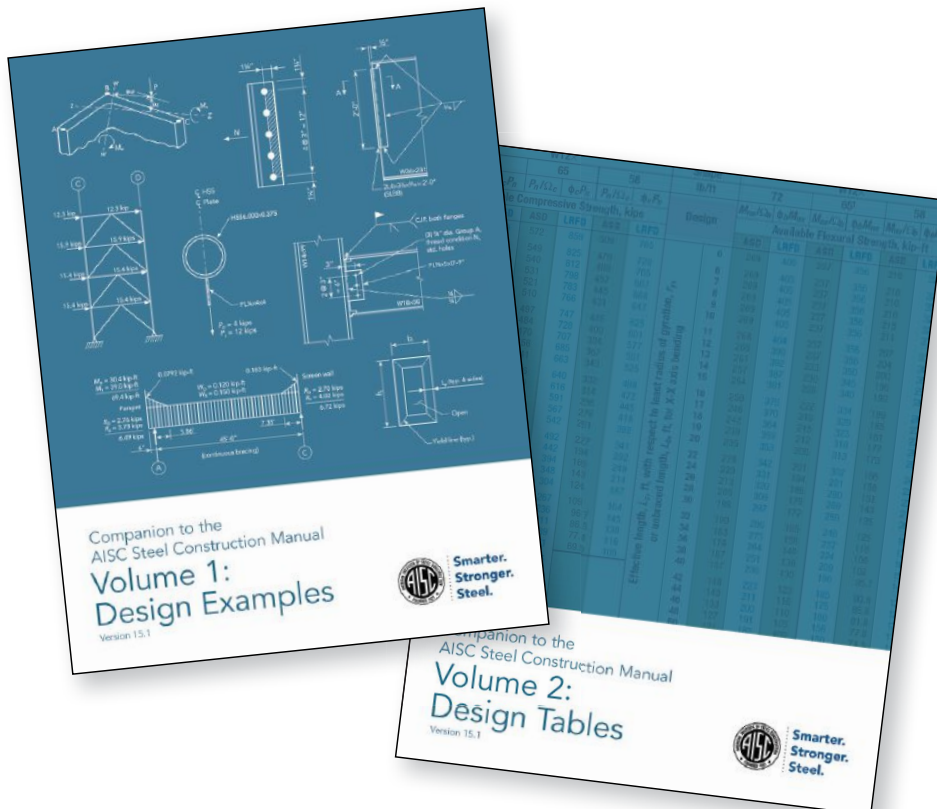

People and Companies

- Modular building manufacturer **Z Modular**, a division of **Zekelman Industries** (parent company of AISC member HSS manufacturer **Atlas Tube**), has commissioned robotics in its new automated manufacturing facility in Killeen, Texas. The specially developed robotics—a first for the construction industry, according to Z Modular—were implemented to ensure greater precision and accelerate production. The Killeen facility is one of several Z Modular manufacturing locations in the U.S.—including a Chicago plant that opened this past summer—and features over 200,000 sq. ft of manufacturing space and 2 million sq. ft of production capacity. Specialized equipment at the Killeen plant includes material-handling robots, welding robots, automated cranes, CNC machines for structural floorboards, conveyors, and 30+ stations for outfitting modules and preparing them for transportation to job sites. The equipment allows a team of nearly 200 tradespeople, engineers, and operations managers to complete up to 80% of a project's total construction within the factory, which is currently producing modules for apartments and hotels.
- Two companies have joined the network of **SEAA/NCCER Ironworker Training Units and Assessment Sites**: **S&H Steel** (an AISC certified member fabricator and erector) and **L&L Construction, Inc.** (an AISC certified erector). The **Steel Erectors Association of America** is an **NCCER Accredited Training Sponsor**, which affords member companies access to nationally recognized credentials, with the benefit of reduced administrative costs. Learn more at seaa.net/craft-training.

MEMBERSHIP AISC Board Approves New Full and Associate Members



Full

Allfasteners USA, LLC,
Medina, Ohio
ARC Steel Enterprises,
Little Mountain, S.C.
CT&C Fabrication,
Grantsville, Utah
Greybeard Steel, LLC,
Post Falls, Idaho
Hub Steel, Groveland, Fla.
Intech Contracting, Lexington, Ky.
RISA Management Corp.,
Maspath, N.Y.
Signature Steel, LLC,
Amarillo, Texas
Southern Spear Ironworks, LLC,
Chattanooga, Tenn.
Team Industries, Inc.,
Kaukauna, Wis.
Turner Construction Co.,
Huntsville, Ala.



Associate

Amcad Solutions, Bangalore, India
Bend-Tech, Osceola, Wis.
DP Steel Detailing,
Point Edward, Ontario, Canada
Drivensteel, Inc., Folsom, Calif.
D's Design and Construction,
Fall River, Mass.
Endproc Technical Services, Inc.,
Calgary, Canada
Global Structural Detailing, Ltd.,
Edmonton, Canada
GSource Technologies, LLC,
Miramar, Fla.
India-Steel, Kolkata, India
Josh Griffin Detailing,
Grand Haven, Mich.
Manni Sipre Spa, Mozzecane, Italy
Ra-Tech Engineering, LLP,
Mumbai, India
Ricardo E. Munoz Detailing,
Chicago
Rocky Point Detailing, LLC,
Las Vegas, Nev.
X Steel Detailing, Sumter, S.C.

Welcome to Safety Matters, which highlights various safety-related items. This month's topics include fall protection, wiring methods, and hearing conservation.

Wiring Methods

General Industry regulations on wiring methods appear in OSHA 1910.305. Most of these regulations are probably best conducted by licensed electricians, but a couple we know to watch for include 305(b) (1)(i)&(ii), which require that openings in electrical boxes be closed and openings with cables be covered.

Fall Prevention

National Safety Stand-Down to Prevent Falls takes place May 4-8. While this may seem to apply more to field erection crews, falls from lower elevations, ladders, and general industry environments can be highlighted during this week as well. Consider sharing one topic related falls with your crews during the stand-down week. In addition, information to improve your fall protection policies is available in several locations. Take some time to review these sources for information on how to reduce fall-from-height injuries and fatalities: osha.gov/stopfalls and safety.nsc.org/fall-from-heights.

Hearing Conservation

Hearing conservation is an important part of any good safety program. In the United States, loss of hearing is ranked third in chronic physical conditions, following arthritis and high blood pressure. The loss of hearing can be brought on in many different ways, but perhaps the most common is due to loud noise exposures in the workplace. Often, these noise exposures slowly diminish a worker's hearing, creating a dangerous misconception that any loss is normal.

The bottom line is that hearing loss is preventable if employers and employees work together to identify and address dangerous noise levels. Employers can reduce exposures by conducting noise studies and providing the correct type of noise-reducing hearing protection or finding alternative methods of producing work. Employees can provide valuable feedback on

comfort of personal protective equipment (PPE) and how job tasks can possibly be augmented to avoid unneeded noise exposures. Helpful hearing conservation ideas:

- Conduct noise monitoring on workplace equipment and processes
- Where possible, use tools and machinery specifically geared towards "quiet" operation
- Follow audiometric testing guidelines from OSHA
- Provide PPE that workers have been able to supply input on
- Train people on how to protect their hearing
- Reevaluate your hearing conservation program regularly

Dates to Note

- Global Employee Health and Fitness Month. Month of May, www.gehfm.org
- Mental Health Awareness Month. Month of May, www.nami.org
- OSHA National Safety Stand-Down to Prevent Falls. May 4-8, www.stopconstructionfalls.com

We are always on the lookout for ideas for safety-related articles and webinars that are of interest to AISC member companies. If you have any safety-related questions or suggestions, we would love to hear them. Contact us at schlafly@aisc.org. And visit AISC's Safety page at aisc.org/safety for various safety resources.

"Safety is something
that happens
between your ears,
not something you
hold in your hands."

—Jeff Cooper

WOMEN IN CONSTRUCTION

AISC Celebrates Women in Construction Week

The first week of March was Women in Construction Week, and we celebrated by highlighting an array of women in the steel industry that week in our online Steel in the News section.

One of the featured women was Natalie Tse, SE, a project manager with Tipping Structural Engineers. Here are her thoughts on how she got her start in the industry, what challenges she's had to overcome, and what changes she'd like to see for the industry moving forward.

How did you get your start in the buildings world?

Tse: In high school, I loved art, math, solving problems, and building and creating things. Unfortunately, I was never really exposed to what engineering was and I definitely wasn't aware of the breadth of career options associated with applied sciences. It wasn't until I was about a year or two into my undergraduate degree that I started to question my decision to study biology and math.

That's when I "discovered" structural engineering: A profession that requires technical skill, spatial awareness, creativity, excellent communication skills, collaboration, patience, perseverance, and curiosity. No matter where you are in your career, every day is unique and the learning never ends.

What barriers or challenges have you had to overcome as a female in the industry?

Tse: As a mother of three children, I experienced some challenges in establishing continued career growth and progression, especially in the early years of parenting. Although I am fortunate to have a husband who believes in gender equity in domestic and caregiving responsibilities, I struggled in finding work-life integration.

After I had my first child, I felt tremendous pressure to get "up to speed" and to "prove my worth" relative to my peers and colleagues. It was an exhausting as well as physically and emotionally challenging period of my life and career. Since I had limited time in the office, I struggled in getting everything I had intended to get done each week, and found myself working late nights and on weekends to meet the demands of my projects. In addition, spending so much time on my career led to feelings of "mommy guilt" and social anxiety with my disconnect from friends who didn't have any children.

Although I successfully pushed hard to attain my credentials and professional licensure, I suffered from feelings of anxiety, stress, and self-doubt associated with my performance and professional competence. These feelings were perpetuated by the fact that my project assignments were considerably less technically challenging than the ones that my male counterparts received. This didn't change until I sought out and requested to be put on specific projects that were aligned with my own development goals.

I was able to alleviate some effects of "imposter syndrome" by forming a huge cohort, seeking support, counsel, encouragement, and accountability in each other's career aspirations. I have also mentored other women who have experienced similar difficulties in their careers. Through continued professional development and learning to swallow my pride by asking for help from peers and managers, I have been able to reduce even more self-doubt and anxiety and attain better work-life balance. Finding advocates who champion and appreciate the talents and skills you possess and contribute to the organization and communities to which you belong is important not



only to your well-being, but also to the success of your career.

What piece of advice would you give to your 10-year-old self?

Tse: Here are a few pieces of advice I would offer to my 10-year-old self:

1. No matter how educated, talented, rich, or cool you think you are, treat everyone with respect. Be kind, courteous, and honest with your peers and with yourself, and show integrity and accountability for your actions.
2. Surround yourself with people who share your values and celebrate your differences.
3. Be courageous. Be bold. Don't be afraid to try something new. Keep an open mind and don't be quick to judge.
4. Be aware of your strengths and weaknesses. Don't let other people put limits on you or to try to define who you are. In every one of your circles, find a mentor and an advocate you can rely on to give you encouragement during your successes *and* through your struggles.
5. Take time to see things from a bird's-eye view. Consider the impact you may have on others around you in your community.

Click the News link at www.modernsteel.com for all six profiles. And for more information about Women in Construction Week, visit www.nawic.org.

PUBLICATIONS

New AISC Standard Available for Public Review

A new AISC standard, *Seismic Provisions for Evaluation and Retrofit of Existing Structural Steel Buildings*, will be available for public review from May 1 to June 15, 2020. The draft document, along with the

review form, will be available for download at aisc.org/publicreview during this time. You can request a printed version (for a \$35 nominal charge) by calling Rachel Jordan at 312.670.5411. Please

submit comments, using the online form, to Cynthia J. Duncan, AISC director of engineering, at duncan@aisc.org by June 15 for consideration.

marketplace & employment



SMITH - EMERY

Inspection • Testing • Metallurgy

Assuring Structure & Life Safety Since 1904

Non-Destructive Testing

- PAUT
- Visual (CWI, CWB, CSWIP)
- MT
- UT

Owner QA

- Fabrication Oversight
- Specification Review
- Field Inspections
- WPS Reviews

Metallurgical Laboratory

- Environmental Laboratory
- Firestop Inspection

Supplier Audits

- IAS
- IAPMO
- City of Los Angeles
- Clark County, NV

Contractor QC

- Fabrication Shop NDT, CWI
- Vendor Audits
- QMS Development
- WPS and PQR Testing

Curtain Wall Performance Testing

- Concrete Testing
- Chemical Laboratory

☎ 1.833.405.0536
 ✉ steel@smithemery.com
 🌐 www.smithemery.com



Structural Engineers

Are you looking for a new and exciting opportunity?

We are a niche recruiter that specializes in matching great structural engineers with unique opportunities that will help you utilize your talents and achieve your goals.

- We are structural engineers by background and enjoy helping other structural engineers find their "Dream Jobs."
- We have over 30 years of experience working with structural engineers.
- We will save you time in your job search and provide additional information and help during the process of finding a new job.
- For Current Openings, please visit our website and select Hot Jobs.
- Please call or email Brian Quinn, PE (616.546.9420 or Brian.Quinn@FindYourEngineer.com) so we can learn more about your goals and interests.
All inquiries are kept confidential.

SE Impact by SE Solutions, LLC | www.FindYourEngineer.com



Contract Auditor

Quality Management Company, LLC (QMC) is seeking qualified independent contract auditors to conduct site audits for the American Institute of Steel Construction (AISC) Certified Fabricators and Certified Erector Programs.

This contract requires travel throughout North America and limited International travel. This is not a regionally based contract and a minimum travel of 75% should be expected.

Contract auditors must have knowledge of quality management systems, audit principles and techniques. Knowledge of the structural steel construction industry quality management systems is preferred but not required as is certifications for CWI, COA or NDT. Prior or current auditing experience or auditing certifications are preferred but not required. Interested contractors should submit a statement of interest and resume to contractor@qmconline.org.

LATE MODEL STRUCTURAL STEEL FABRICATING EQUIPMENT

Peddinghaus AFCPS 823-B CNC Anglemaster Angle Punch & Shear, 8" x 8" x 3/4", 400 T Shear, 130 T Punch, PC Based, 2017 Upgrade #30583

Peddinghaus AFCPS 833A Revolution CNC Anglemaster Angle Line, 8" x 8" x 1", Fagor 8055 CNC, Loader, Conveyor, 2011 #29959

Peddinghaus Anglemaster AFPS-643E CNC Angle & Flat Bar Line, 6" x 6" x 1/2", 200 T Shear, 66 T Punch, Fagor 8025, 40' Conveyor #30325

Voortman V806M Robotic Structural Plasma Coping System, 6-Axis Panasonic Robot, HPR400XD Plasma, Conveyor, 2009 #30451

Peddinghaus PCD-1100/3C, 3-Spindles w/ATC, 44"W x 18" H, Siemens CNC, 4-Side Marking, Meba Saw, Conveyor, 2013, #30677

Roundo Model R-13-S Section Bending Machine, 8" x 8" x 1.25" Leg In, 31.5" Dia Rolls, 105 HP, Universal Rolls #29237



Visit our website or call to inquire about our Featured Machines
claire@prestigeequipment.com

www.PrestigeEquipment.com | (631) 249-5566

Search employment ads online at www.modernsteel.com. To advertise, contact M.J. Mrvica Associates, Inc.: 856.768.9360 | mjmrvica@mrvica.com

advertiser index

AISC	3 8 15 67	QuickFrames USA	53
Applied Bolting	24	SDS/2	7
Bull Moose Industries	back cover	SidePlate	12
Chicago Metal Rolled Products	26-27	St. Louis Screw & Bolt	53
CoreBrace LLC	24	Tnemec Company	14
FICEP	11	V&S Galvanizing LLC	13
JGM	25	Voortman Corporation	19
Nucor Vulcraft-Verco Group – Redicor	5	Whitefab, Inc.	23
Peddinghaus Corporation	2		

structurally sound



LONE STAR BRIDGES

THE AISC STUDENT STEEL BRIDGE COMPETITION (SSBC) Texas Regional event in Arlington in early March was supposed to kick off SSBC season as the first of 18 regional events leading up to the national finals at Virginia Tech in Blacksburg, Va.

But we all know what happened next. The events—along with everything else—became part of the rolling list of cancellations that, as of this printing, still continues thanks to the Coronavirus/COVID-19 pandemic. And so the Texas event, held at Esports Stadium in Arlington, would be the only 2020 SSBC event to take place.

But take place it did, with four Texas teams making the trip from as close as a couple miles away to all the way across the state

(which, in the case of Texas, is pretty far): University of Texas at Arlington, University of Texas at San Antonio, University of Texas Tyler Houston Engineering Center (you read that right; the main campus is in Tyler while the engineering department is based in Houston), and University of Texas at El Paso.

UTSA took first place overall as well as in five of six categories: construction speed, economy, efficiency, lightness, and stiffness, and second place in aesthetics (first place in that category went to UT Tyler).

For the complete results, visit texas.studentsteelbridge.org. And for photos of the event, see the Project Extras section at www.modernsteel.com.

RESILIENCE MATTERS.

No other structural material is as strong as steel.

.....

Read our white paper on

"The Impact of Material Selection on the Resilience of Buildings"

at aisc.org/discover.



Smarter. Stronger. Steel.
.....
American Institute of Steel Construction
312.670.2400 | www.aisc.org

HOLLOW STRUCTURAL STEEL TUBE FROM BULL MOOSE

**BUILD A
LANDMARK.**



For projects that will stand the test of time, start with Bull Moose HSS tube.

Our direct-form manufacturing process enables us to use the highest grade HSLA steel...and form it directly into a tube.

With sizes ranging from 1.5" square to 18"x6", and wall thicknesses from 1/8" through 5/8", Bull Moose features one of the largest size ranges of HSS products in the industry.

For strength, versatility and reliability, build with Bull Moose.

BULL MOOSE ADVANTAGES

- Strength ranges of 46 KSI to 110 KSI
- Tighter tolerances, sharper edges, and straighter tubes
- Widest variety of custom sizes/lengths, including metric
- In-line NDT weld testing available on all tube
- Readily available weathering grade steel
- Fast delivery with 8 domestic sites



BULL MOOSE
For exceptional strength.

1819 Clarkson Rd.
Chesterfield, MO 63017

800.325.4467 | **BULLMOOSETUBE.COM**