

Modern Steel Construction

May 2022

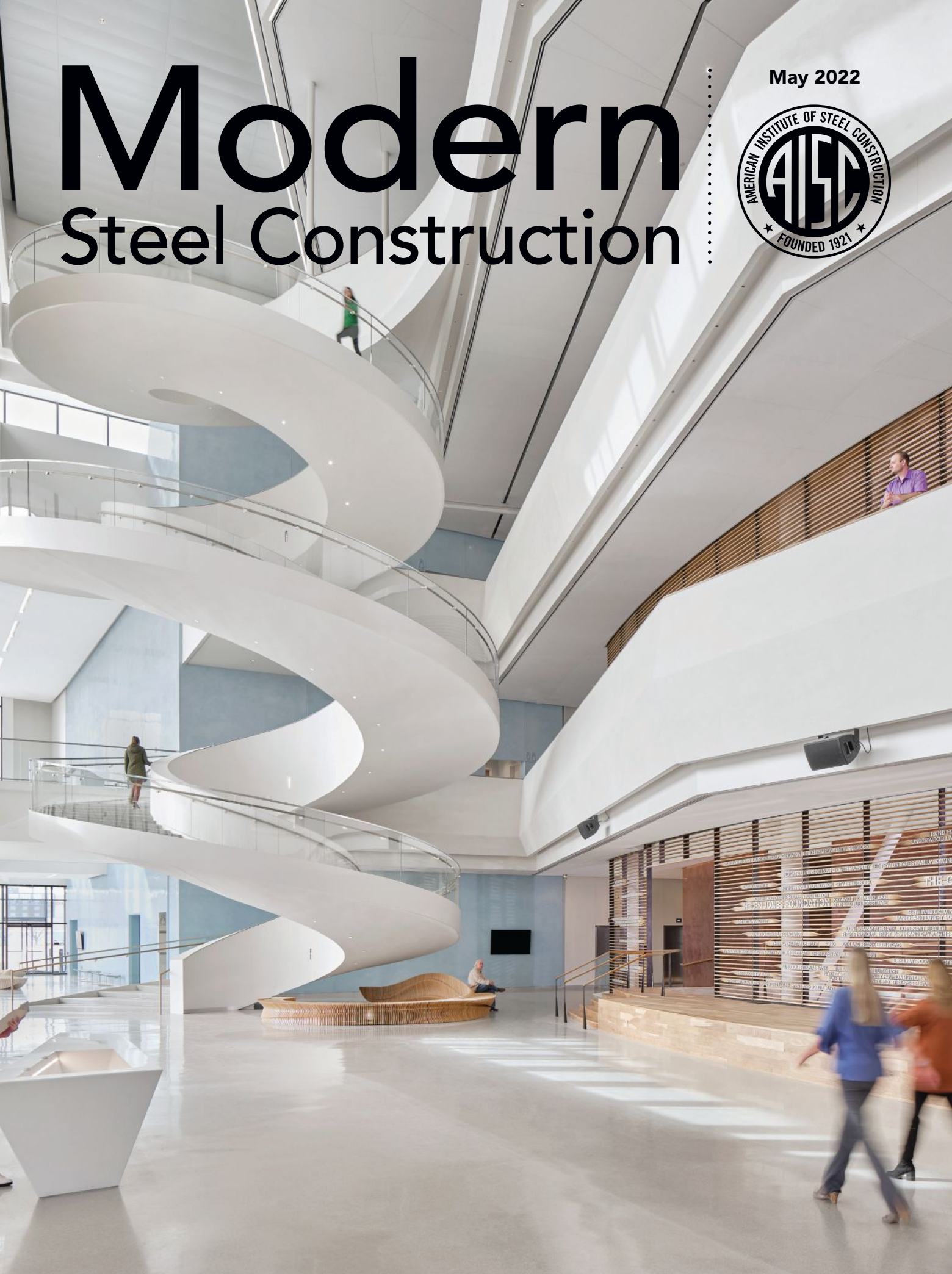

THE FASTEST DRILL

LINE IN THE STEEL INDUSTRY

- Simultaneously mill copes, flange thins, rat holes and more with each drilling axis
- Simultaneously arcwrite piece marks, weld symbols and more on all 4 sides of material
- Each high speed 25 HP drill spindle has an operating window of 19-11/16"

www.peddinghaus.com/steel/subx

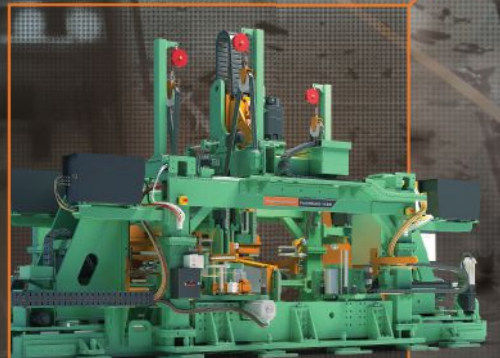

THE
PEDDISUBX-1120

Peddinghaus

STRONGER THAN
STEEL®

www.peddinghaus.com | info@peddinghaus.com | (815) 937-3800

We've Got Your Shop



Our new Conversion Tool takes the stress out of changing platforms

Whether you were affected by the recent departure of a similar solution or you're just looking for a better alternative, rest assured Tekla PowerFab has your shop's back.

Tekla PowerFab is the industry's complete steel fabrication management solution, designed to improve shop efficiencies, mitigate the risk of errors and facilitate greater collaboration—all while remaining flexible enough to integrate well with any workflow. Our dedication to the steel industry and proven track record of innovations, like the new Conversion Tool, gives our clients the peace of mind that Tekla PowerFab will continue to meet their needs into the future. To learn more please visit tek.la/choose-tekla.

Modern Steel Construction

May 2022

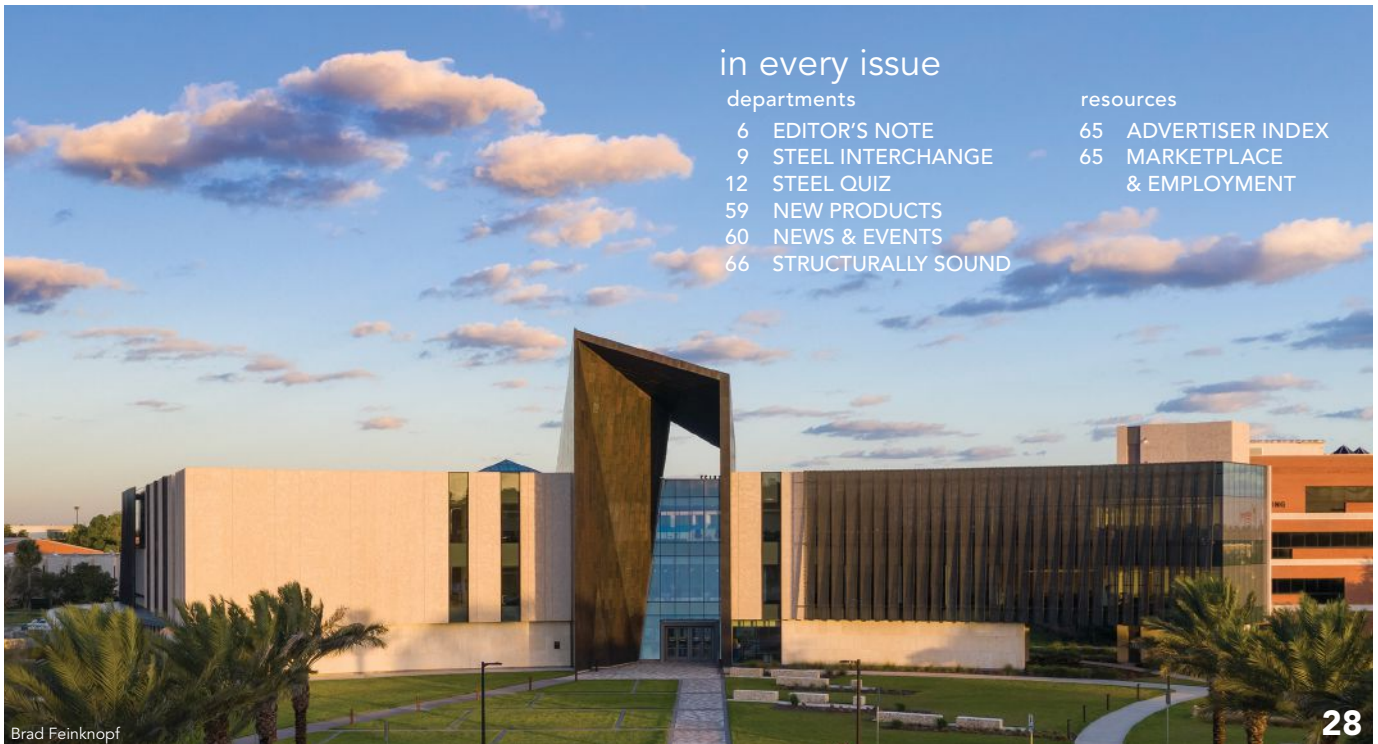

in every issue

departments

- 6 EDITOR'S NOTE
- 9 STEEL INTERCHANGE
- 12 STEEL QUIZ
- 59 NEW PRODUCTS
- 60 NEWS & EVENTS
- 66 STRUCTURALLY SOUND

resources

- 65 ADVERTISER INDEX
- 65 MARKETPLACE & EMPLOYMENT

features

28 2022 IDEAS² Awards
This year's IDEAS² Award winners range from a Seattle high-rise using a first-of-its-kind core system to a staircase that looks like a floating ribbon to a performance venue named for a rock-and-roll pioneer.

56 Steel Space
BY BRIAN MARKHAM, PE, AND BOB VINCENT
A handful of strategic steel solutions help launch the Space Needle into the future.

columns

steelwise

16 Practical Point Load Determination
BY RAFIK GERGES, SE, PhD, AND WEIAN LIU, SE, PhD
Tips for more efficiently determining point loads for composite elevated deck slabs.

data driven

20 Certified Quality
BY JOE DARDIS
More and more steel fabricators and erectors—as well as the companies who employ them—are seeing the benefits of AISC certification. And it's easier to find them now, more than ever.

field notes

22 The Long Run
INTERVIEW BY GEOFF WEISENBERGER
University of Illinois engineering professor Larry Fahnestock takes a proactive approach to teaching, advising, and covering great distances.

business issues

24 Hitting Reset
BY DAN COUGHLIN
If a conversation starts to get ugly, remember to step back, be mindful of what's happening below the surface, and hit the reset button.

ON THE COVER: A steel staircase worthy of a rock-and-roll icon highlights the lobby of the Buddy Holly Hall of Performing Arts and Sciences, one of this year's IDEAS² Award winners, p. 28. (Photo: Casey Dunn)

MODERN STEEL CONSTRUCTION (Volume 62, Number 5) ISSN (print) 0026-8445; ISSN (online) 1945-0737. Published monthly by the American Institute of Steel Construction (AISC), 130 E Randolph Street, Suite 2000, Chicago, IL 60601. Subscriptions: Within the U.S.—single issues \$6.00; 1 year, \$44. Outside the U.S. (Canada and Mexico)—single issues \$9.00; 1 year \$88. Periodicals postage paid at Chicago, IL and at additional mailing offices. Postmaster: Please send address changes to MODERN STEEL CONSTRUCTION, 130 E Randolph Street, Suite 2000, Chicago, IL 60601.

DISCLAIMER: AISC does not approve, disapprove, or guarantee the validity or accuracy of any data, claim, or opinion appearing under a byline or obtained or quoted from an acknowledged source. Opinions are those of the writers and AISC is not responsible for any statement made or opinions expressed in MODERN STEEL CONSTRUCTION. All rights reserved. Materials may not be reproduced without written permission, except for noncommercial educational purposes where fewer than 25 photocopies are being reproduced. The AISC and Modern Steel logos are registered trademarks of AISC.



Printed on paper made from a minimum of 10% recycled content.

 **Atlas** *Tube*

AMERICA REINFORCED



As the country comes together to restore the health of our national infrastructure, Atlas Tube is proud to play a supporting role providing quality steel products and components all made right here in America.

 **Zekelman** *Industries*

Life Reinforced

editor's note



There are plenty of types of wind tunnel facilities out there. The one I visited, as you may have guessed, was built to test buildings. Specifically, it can test exhaust paths for, or wind forces on, prospective buildings.

For the first type of test, facility staff build a model of the test building, surrounding structures, and significant geographic features and place it on a rotating table to be situated in the tunnel. When the wind blows, they can monitor the paths of exhaust coming from the test building to see where it goes and how it affects surrounding buildings. Since the table rotates, they can simulate wind coming from any direction. The second type of test (wind loads) is similar but involves placing several sensors on the test building model to see how wind will affect the structure in its real-world environment.

It was a fascinating experience that anyone involved in buildings—or really, anyone who just likes seeing cool stuff—should try if they can. Side note: At one point during the tour, when I was looking at a replica of the downtown area of a major American city, I couldn't help but think, "This is what Godzilla must feel like." My request to stomp around, screeching and demolishing buildings, was denied. Alas.

I should mention what facilitated this tour. It was part of NASCC: The Steel Conference, which took place in March in Denver. In addition to the more than 230 exhibitors and more than 200 technical sessions—not to mention the educational opportunities and after-hours events like the Elevate Reception and the Conference Bar Hop/Dinner—the conference offered opportunities for a few dozen attendees to

Have you ever been in a wind tunnel?

I recently paid my first visit to one. (Spoiler alert: It was windy.)

take tours related to the steel construction industry; in addition to the wind tunnel, a handful of attendees were also able to visit an ironworker training center and a steel service center. (By the way, CPP Wind Engineering Consultants hosted the wind tunnel tour at their facility in Windsor, Colo. We thank them for their gracious hospitality, and you can learn more about what they do at www.cppwind.com.)

And we do this sort of thing every year. If you weren't one of the approximately 4,800 attendees to make it to the conference—our first in-person rendition since 2019—keep an eye out for such opportunities at future Steel Conferences (on that note, next year's conference is scheduled for April 12–14 in Charlotte).

And if you were one of those folks who braved the still-somewhat-surreal airline travel experience, or were perhaps within driving or commuter train distance and had long been hoping for the Steel Conference to come to the Mile High City, it sure was good to be back, wasn't it? (I should add that our streaming attendees totaled more than 2,000.) In some ways, it felt like it had been forever since we'd all met in person... while in others, it felt like no time had passed at all.

I have a lot more to say about the conference, so look for a more comprehensive roundup in next month's issue. Meanwhile, thank you to everyone who attended or presented at this year's Steel Conference in Denver—whether in person or online—and made it a roaring success!

Geoff Weisenberger
Chief Editor

Modern Steel Construction

Editorial Offices

130 E Randolph St, Ste 2000
Chicago, IL 60601
312.670.2400

Editorial Contacts

CHIEF EDITOR
Geoff Weisenberger
312.493.7694
weisenberger@aisc.org

PUBLISHER
Keith A. Grubb, SE, PE
312.804.0813
grubb@aisc.org

GRAPHIC DESIGN MANAGER
Kristin Hall
773.636.8543
hall@aisc.org

EDITORIAL DIRECTOR
Scott Melnick
312.804.1535
melnick@aisc.org

AISC Officers

CHAIR
Stephen H. Knitter
Geiger & Peters, Inc.
VICE CHAIR
Hugh J. McCaffrey
Southern New Jersey Steel Co.

SECRETARY/LEGAL COUNSEL
Edward Seglias, Cohen Seglias
Pallas Greenhall & Furman, PC

PRESIDENT
Charles J. Carter, SE, PE, PhD
SENIOR VICE PRESIDENT
Scott Melnick

SENIOR VICE PRESIDENT
Mark W. Trimble, PE

VICE PRESIDENT
Todd Alwood

VICE PRESIDENT
Carly Hurd

VICE PRESIDENT
Lawrence F. Kruth, PE

VICE PRESIDENT
Mike Mospan

VICE PRESIDENT
Brian Raff

Editorial Advisory Panel

Brandon Chavel, PE, PhD
Michael Baker International
Nat Killpatrick
Basden Steel

Christina McCoy, SE
Oklahoma State University
School of Architecture

Allison Shenberger, PE
ruby+associates

Justin Smith, PE
Walter P Moore

Advertising Sales

M.J. Mrvica Associates, Inc.
2 W Taunton Avenue
Berlin, NJ 08009
856.768.9360
mjmrvica@mrvica.com

Address Changes and Subscription Concerns

312.670.2401
subscriptions@aisc.org

Reprints

Kristin Hall
hall@aisc.org



Better fabrication starts with SDS2.

The right detailing software can drive efficiency and profitability in your fabrication shop. With SDS2, you can quickly build and adapt the detailing model to suit your needs, integrate seamlessly with any MRP, MIS and tracking system, and maximize returns on your automated equipment.

Efficiency, accuracy, results—it all starts with SDS2. Get started today at sds2.com/start.



now part of

ALLPLAN
A NEMETSCHEK COMPANY

SDS2 2022 NOW AVAILABLE

Grow your Knowledge with AISC Continuing Education

Night School Vertical Bracing Connections— From Basic Principles to Design

Tuesdays, 7:30–9:00 p.m. ET

- 5/3 Uniform Force Method, Part 2 | Bill Thornton
- 5/10 Vertical Bracing Corner Connection – Seismic
Rafael Sabelli
- 5/17 Chevron Gusset Connection | Rafael Sabelli
- 5/24 Other Connection Topics and Case Studies
Carol Drucker

aisc.org/nightschool

Three-part Live Webinar Series— Structural Stainless Steel

Presented by Catherine Houska, Nancy Baddoo,
Francisco Meza, Jason Provines, and Benjamin Baer
May 5, 12, and 19

aisc.org/webinars



Smarter. Stronger. Steel.

American Institute of Steel Construction
312.670.2400 | www.aisc.org

steel interchange

If you've ever asked yourself "Why?" about something related to structural steel design or construction, *Modern Steel's* monthly Steel Interchange is for you!

Send your questions or comments to solutions@aisc.org.

Protected Zone Clarification

The commentary to the AISC *Seismic Provisions for Structural Steel Buildings* (ANSI/AISC 341) suggests attachments to gusset plates embedded in ground-floor concrete slabs may be used to resist horizontal forces at the base of braced-framed systems (see Figure 1). Is this a prohibited attachment to the protected zone? Does *Seismic Provisions* Section I2.1 permit the engineer of record (EOR) to use this type of connection?

This type of connection is not prohibited by the *Seismic Provisions*. It is common for engineers to add drag elements to special concentrically braced frame (SCBF) or buckling restrained braced frame (BRBF) gussets at base connections to transfer horizontal forces into concrete foundations. These elements should be made with appropriate materials permitted by Section A3 of the *Seismic Provisions*, including weld-toughness requirements of Section A3.4(a). It is good practice to keep such welds clear from flame-cut gusset edges.

Note that taking horizontal force out through the ground floor concrete slab is a different load path from a traditional one where the anchor rods are in shear. The work point changes and the demand on the anchor rods also change (see Figure 2).

As shown in Figure 2, the vertical load, F_v , would shift by an amount "x" in order to satisfy statics where:

$$F_v(x) = F_b(y)$$

Rafael Sabelli, SE, PE

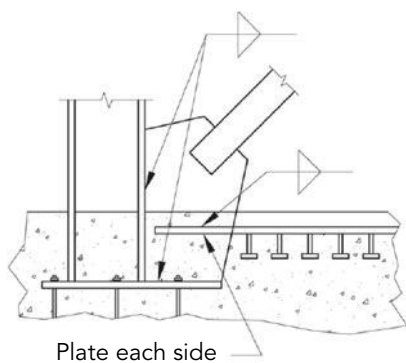
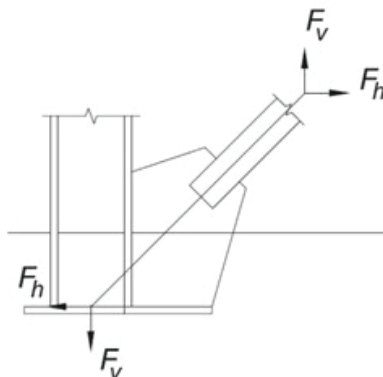
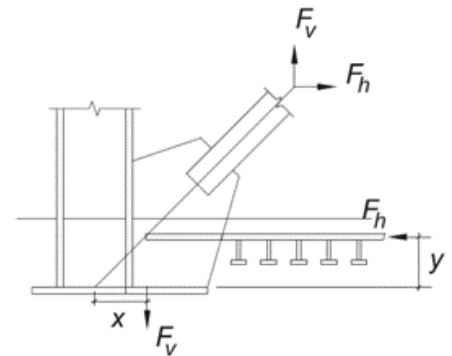

Fig. 1. An example of a shear transfer to a concrete grade beam (see commentary Figure C-D2.6 in the AISC *Seismic Provisions*).



a. With horizontal force transfer as base plate



b. With horizontal force transfer at slab level

Fig. 2. Embedded Gusset Plate—change in Force Distribution.

Accommodation of Brace Buckling at Embedded Gusset Plate Connections

At building foundations, base plates are often located below a concrete slab. How does embedding the gusset plate impact the accommodation of brace buckling?

Seismic Provisions Section F2.6c.3 provides requirements that address the accommodation of brace buckling. The engineer should detail the connection either to provide brace fixity or rotation

capacity. If the detail is to achieve fixity, then the embedment or attachments must develop the full brace expected flexural strength per *Seismic Provision* Section F2.6.3(a), forcing the plastic hinge from brace buckling to occur at the top of the slab. (Providing a fixed steel-to-steel connection embedded in concrete satisfies this requirement.) Conversely, if the detail is to provide rotation capacity, the gusset may be extended such that the gusset

hinge per Section F2.6.3(b) may form clear of the concrete and any attachments, using the concrete embedment and any embedded attachments for gusset stability. Alternatively, a substantial block-out may be provided, sufficient to allow rotation of the brace end consistent with brace buckling and lateral deformation corresponding to the design earthquake displacement.

Rafael Sabelli, SE, PE

Minimum Bolt Edge Distance

AISC *Specification for Structural Steel Buildings* (ANSI/AISC 360) Table J3.4 shows the minimum edge distance. Footnote [a] states, “If necessary, lesser edge distances are permitted provided the applicable provisions from Sections J3.10 and J4 are satisfied, but edge distances less than one bolt diameter are not permitted without approval from the engineer of record.” I assume that the requirements in Sections J3.10 and J4 must always be satisfied. Does this mean that the minimum edge distance listed in Table J3.4 are recommendations and not requirements?

Yes, Table J3.4 is, in effect, a recommendation. However, it is probably best viewed as a very *strong* recommendation. Information similar to Table J3.4 has appeared in the *Specification* since at least 1936. The values in Table J3.4 are typically conformed to unless there are very compelling reasons to do otherwise.

Larry Muir, PE

TABLE J3.4
Minimum Edge Distance^[a] from
Center of Standard Hole^[b] to Edge of
Connected Part, in.

Bolt Diameter, in.	Minimum Edge Distance
1/2	3/4
5/8	7/8
3/4	1
7/8	1 1/8
1	1 1/4
1 1/8	1 1/2
1 1/4	1 5/8
Over 1 1/4	1 1/4d

^[a] If necessary, lesser edge distances are permitted provided the applicable provisions from Sections J3.10 and J4 are satisfied, but edge distances less than one bolt diameter are not permitted without approval from the engineer of record.
^[b] For oversized or slotted holes, see Table J3.5.

Reusing Anchor Rods

I am having trouble finding any documentation discussing the reuse of anchor rods. We are looking to replace an existing vertical vessel with a new one. As long as the anchor rods are rechecked and verified that they are adequate from a steel and concrete strength perspective, are there any codes/regulations that have restrictions on this, or any discussions surrounding the proper way to go about doing this?

The application you describe falls outside the scope of the *Specification*. I am not surprised that you could not find guidance provided by AISC because the *AISC Specification* addresses the design of buildings. It is uncommon to remove a building at its anchors and then reuse the anchors. To my knowledge, there are no standards that address this condition.

OSHA Subpart R requires that the controlling contractor (usually the general contractor or construction manager) provide written notifications that any repairs or modifications to anchor rods be provided

to the steel erector. It would not be unusual in the case you are presenting to require that a “pull test” be performed on each existing anchor rod to ensure that it meets the required capacity of the design loading. This would test not only the capacity of the anchor rod but also the embedment and the condition of the concrete.

Anchor rods are not high-strength bolts. Provisions on the reuse of high-strength bolts (in the *RCSC Specification*) should not be used in evaluating anchor rod capacity.

Larry Kruth, PE

Larry Kruth (kruth@aisc.org) is AISC's vice president of engineering and research.

Larry Muir is a consultant to AISC.

Rafael Sabelli is managing director of Walter P Moore's San Francisco office as well as director of seismic design.



STEEL SOLUTIONS CENTER

Steel Interchange is a forum to exchange useful and practical professional ideas and information on all phases of steel building and bridge construction. Contact Steel Interchange with questions or responses via AISC's Steel Solutions Center: 866.ASK.AISC | solutions@aisc.org

The opinions expressed in Steel Interchange do not necessarily represent an official position of the American Institute of Steel Construction and have not been reviewed. It is recognized that the design of structures is within the scope and expertise of a competent licensed structural engineer, architect or other licensed professional for the application of principles to a particular structure.

The complete collection of Steel Interchange questions and answers is available online at www.modernsteel.com.



www.ironworkers.org

IRON WORKERS INTERNATIONAL SETS THE STANDARD HIGH WITH **ACCREDITED RIGGER & SIGNAL PERSON CERTIFICATION**

The National Commission for Certifying Agencies (NCCA), the accrediting body of the Institute for Credentialing Excellence, has granted accreditation to the Iron Workers International Certification Board's (I.I.C.B.) Rigging & Signalperson Certification Program.

WHY IS IT IMPORTANT?



MEET REQUIREMENTS

OSHA's Subpart CC requires signal person qualification by a third-party qualifier.



MEET DEMAND

While an OSHA letter of interpretation recognizes apprenticeship programs that train and assess riggers and signal persons as third-party qualified evaluators, many contractors, states and municipalities require a Qualified Rigger and Signal Person Certification.



REDUCE COST

Third party certification comes with a hefty price tag without input on testing from subject matter experts, ironworkers and their contractors. The Iron Workers' certification eliminates the recertification cost of \$500 per person.



IMPROVE SAFETY

Ensuring that only trained, skilled and competent ironworkers complete rigging and signaling tasks elevates workplace safety standards and reduces risk.

WHAT IS IT?

Iron Workers International Certification Board's (I.I.C.B.) Rigging & Signalperson Certification Program is accredited by the National Commission for Certifying Agencies (NCCA), the accrediting body of the Institute for Credentialing Excellence. The I.I.C.B. joins an elite group of more than 130 organizations representing over 315 programs that have obtained NCCA accreditation.

HOW IS IT DONE?

- 6,000 HOURS OF HANDS ON EXPERIENCE
- 3-PART EXAM
- TESTING & RECERTIFICATION EVERY 5 YEARS
- IRON WORKERS RIGGING & CRANE COURSE

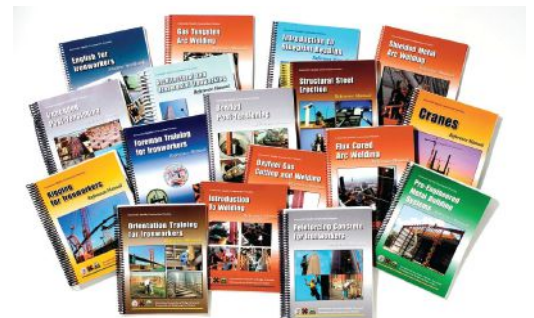

steel quiz

This month's questions and answers were developed by Michael Desch, an AISC intern and current graduate student at the Illinois Institute of Technology. Thanks, Michael!

This month's Steel Quiz looks at some of the many bridge design topics covered in the NSBA *Steel Bridge Design Handbook* (which you can download at aisc.org/bridgehandbook).

- 1 The NSBA *Steel Bridge Design Handbook* was recently updated to which version of the *AASHTO Bridge Design Specification*?
a. 8th edition
b. 9th edition
c. 10th edition
d. 11th edition
- 2 Which of the following types of redundancy is based on the number of main supporting members between support points?
a. Load-path redundancy
b. Structural redundancy
c. Internal redundancy
d. External redundancy
- 3 **True or False:** Bolted field splices in flexural members should be proportioned to prevent slip during deck casting.
- 4 **True or False:** The best defense against distortion-induced fatigue cracking is to address it during the detailing phase as opposed to the design phase.
- 5 Intermediate diaphragms or cross frames shall be normal to the girder when the skew angle is greater ____.
a. 10°
b. 15°
c. 20°
d. 25°
- 6 **True or False:** When designing a bottom flange splice for a box girder, the longitudinal warping stresses due to cross-sectional distortion must be considered.
- 7 This high-load multi-rotational (HLMR) bearing type contains an unconfined elastomeric element that is stiff against compression and rotation but is free to bulge.
a. Pot bearing
b. Disc bearing
c. Spherical bearing
d. Elastomeric bearing

TURN TO PAGE 14 FOR THE ANSWERS

INNOVATE FREELY

2020 IDEAS² AWARD WINNER
Structures/Art Installation
Non-Building Structures

CTA Belmont Station Canopy, IL
Architect: Ross Barney Architects
Structural Engineer: exp global
with Simpson Gumpertz & Heger
Photography by Ross Barney Architects

**CREATIVE.
TRANSFORMATIVE.
INTEGRATED.**

CAST CONNEX[®] provides custom casting design-build services for projects that benefit from a design composition unachievable by conventional fabrication methods.

Customizable Solutions

- Simplifies complex connections
- Ideal for architecturally exposed applications
- Resolves connections subject to very high loading or fatigue
- Economically addresses repetitive details with high-quality and consistency

CUSTOM CASTING

CASTCONNEX[®]
innovative components for inspired designs

www.castconnex.com

info@castconnex.com 1-888-681-8786

SINCE
1930

WORLD LEADER IN CNC MACHINE MANUFACTURING

FICEP is **the largest producer in the world** today of automated systems for the fabrication of

STRUCTURAL STEEL

BEAM PROCESSING

EXCALIBUR



Single Spindle CNC Horizontal Drilling Lines

ORIENT



Single Spindle CNC Profile Processing Lines

VANGUARD



Three Spindle CNC Profile Processing Lines

VALIANT



Three Spindle CNC Profile Processing Lines

ENTERPRISE



CNC Gantry Drilling Lines

NOZOMI



CNC 9 Axes Coping Lines

FLEX



CNC Coping Lines

KATANA



Band Sawing Lines

PLATE PROCESSING

P RANGE



CNC Punching, Drilling and Marking Systems

TIPO D



CNC Drilling, Notching and Sawing Systems

KRONOS



CNC Drilling and Thermal Cutting Systems

GEMINI



CNC Drilling, Milling and Thermal Cutting Systems

TIPO G



CNC Drilling, Marking and Thermal Cutting Systems

TIPO A



CNC Drilling, Marking and Thermal Cutting Systems

TIPO B



CNC Punching, Marking and Thermal Cutting Systems

ENERGY



CNC Plate Edge Milling, Scribing and Marking Systems

ANGLE & FLAT PROCESSING

XP R



CNC Punching, Drilling, Marking and Shearing Lines

SP range



CNC Punching and Shearing Lines

XP T



High Performance CNC Punching and Shearing Lines

RAPID



CNC Drilling, Marking and Cutting Lines

SURFACE TREATMENT

SHOTBLASTING



Surface Treatment Systems



www.ficepcorp.com



FICEP Corporation
2301 Industry Court - Forest Hill Industrial Park - Forest Hill, MD 21050 - USA
Tel +1 410 588 5800 • Fax +1 410 588 5900 • email: info@ficepcorp.com

Everyone is welcome to submit questions and answers for the Steel Quiz. If you are interested in submitting one question or an entire quiz, contact AISC's Steel Solutions Center at 866.ASK.AISC or solutions@aisc.org.

- 1 **b.** The NSBA *Steel Bridge Design Handbook* was recently updated to be current with the 9th edition of the *AASHTO LRFD Bridge Design Specifications*.
- 2 **a.** Load-path redundancy. These members, such as girders or trusses, are usually parallel. A member is considered load-path

redundant if an alternative and sufficient load path is determined to exist. Refer to Chapter 9: Redundancy, Section 1.2 for more information.

- 3 **True.** Bolted field splices must be proportioned to control permanent deformations under overloads caused by a slip in joints that could adversely affect the serviceability of the structure. They

must also be proportioned to prevent slip under the maximum actions induced during the casting of the concrete deck. Refer to Chapter 14: Splice Design, Section 5.2 for more information.

- 4 **True.** This type of fatigue crack growth results from the imposition of relatively small deformations, usually out-of-plane, in local regions of a member. These deformations are difficult to estimate in the design process. The primary defense against this source of cracking is proper detailing. Refer to Chapter 12: Design for Fatigue, Section 2.4 for more information.

- 5 **c.** 20°. For skew angles greater than 20°, the 9th Edition *AASHTO LRFD Bridge Design Specifications*, Article 6.7.4.2 requires intermediate diaphragms and cross frames to be normal to the girder. If the skew angle is less than 20°, the publication allows intermediate diaphragms and cross frames to be parallel to the skew angle. Refer to Chapter 13: Bracing System Theory and Design for I-Girders and Tub Girders, Section 2.1.1 for more information.

- 6 **False.** Longitudinal warping stresses due to cross-section distortion may be ignored at the strength limit state since the bottom flange splices are designed to develop the full design yield capacity of the flanges. These longitudinal warping stresses are typically relatively small in the bottom flange at the service limit state and for constructability and may be neglected when checking the bottom flange splices for slip. Refer to Chapter 14: Splice Design, Section 7.1 for more information.

- 7 **b.** Disc bearing. This is one example of an HLMR bearing. Horizontal forces are transmitted from an upper load plate to either a shear pin at the center of the disc or to a restricting ring. Disc bearings represent a simpler alternative to pot bearings and spherical bearings and have become more popular due to their relatively low cost, durability, and reduced maintenance demands. Refer to Chapter 15: Bearing Design, Section 2.2.2 for more information.



Calculate yesterday's estimates

HOW WOULD YOU DESIGN THESE CONNECTIONS?

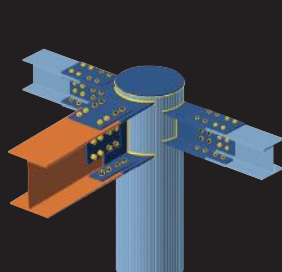
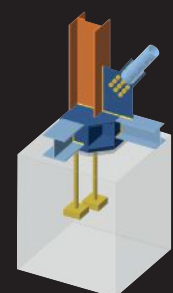
NOW, THERE IS A SOFTWARE THAT CAN.

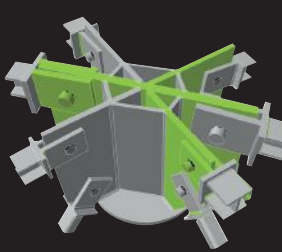
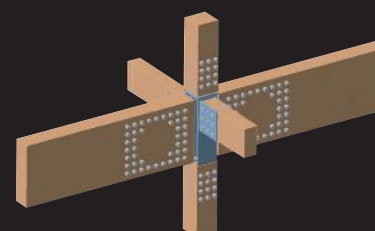
Request a DEMO on

www.ideastatica.com



Quality Management Company, LLC (QMC) is seeking qualified

INDEPENDENT CONTRACT AUDITORS

to conduct site audits for the American Institute of Steel Construction (AISC) Certified Fabricators and Certified Erector Programs.

This contract requires travel throughout North America and limited International travel. This is not a regionally based contract and a minimum of 75% travel should be expected.

Contract auditors must have knowledge of quality management systems, audit principles and techniques. Knowledge of the structural steel construction industry quality management systems is preferred but not required as is certifications for CWI, CQA, or NDT. Prior or current auditing experience or auditing certifications are preferred but not required.

Interested contractors should submit a statement of interest and resume to contractor@qmcauditing.com.

Practical Point Load Determination

BY RAFIK GERGES, SE, PHD, AND WEIAN LIU, SE, PHD

Tips for more efficiently determining point loads for composite elevated deck slabs.



Fig. 1. Schematics of a composite steel floor slab.

CONCRETE OVER METAL DECK

is a very common construction method for elevated slabs for a wide range of building types, including steel-framed commercial and industrial buildings. The composite action between profiled steel decking and concrete slab provides a solid design solution for supporting both lateral and gravity loads.

When it comes to industrial buildings, concrete and metal deck must often support platforms or heavy equipment that potentially impose large, concentrated loads. Adding wide-flange steel beams below the deck is a typical solution. However, it's not always preferable as it can increase cost and schedule, as well as requires prior coordination.

In situations where the wide-flange option isn't feasible, relying on the composite deck itself to support the large point loads becomes essential and inevitable. The Steel Deck Institute (SDI) publishes a design manual for floor deck that provides tables for composite deck shear and moment capacity, though it's not always easy to quickly determine point load capacity using these tables. Here, we've proposed a quicker method for looking up composite slab point load capacity for a variety of deck profiles and design variables is presented.

General Design Considerations

When a concentrated load is acting on the composite slab, there are five ultimate limit states (LS) that need to be considered: one-way shear, punching shear, positive bending, negative bending, and weak-axis bending, as shown in Figure 2. (Note that for industrial buildings, weak-axis bending of the slab typically does not govern.)

To investigate how each limit state governs the ultimate point capacity of the composite floor slab, consider the common industrial building composite floor construction type shown in Figure 3. In this configuration, the gravity beams are equally spaced 6 ft on center and the composite slab is composed of inverted 1.5-in.

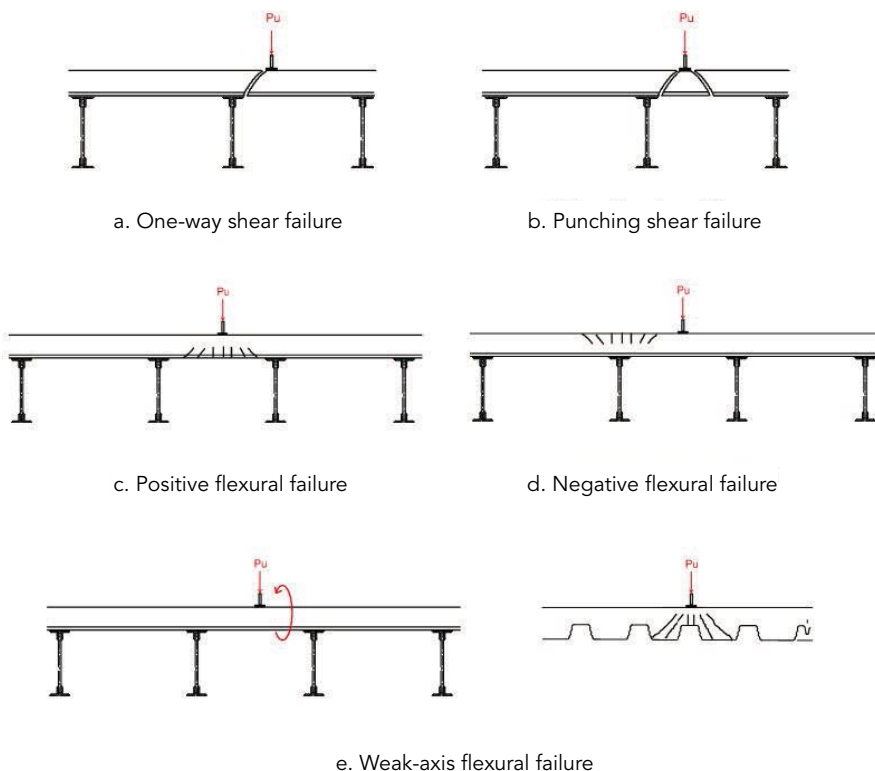

Fig. 2. Composite deck limit states.

metal deck topped with 3.5-in. normal-weight concrete. Welded wire reinforcement (WWR) is placed over the metal deck to control the cracks induced by shrinkage and temperature. Structurally, it also serves as flexural reinforcement that enables the deck to resist negative bending. As such, the composite deck subjected to concentrated load can be considered the point load acting on a continuous beam. For this example, three continuous spans are considered in the analysis, and the point load is located at the middle span.

Here, the main design variables include span, the base plate dimensions where the point load is being applied (wplate), concrete strength, and the thickness of the concrete slab over metal deck. The dimension of the base plate is a very important variable as it directly determines the size of the critical perimeter for punching shear and thereby dictates the two-way shear capacity. To investigate the effect of each variable on the point load capacity, each parameter varies, per Table 1.

Table 1. Design variable range

Design Variable Variation	
Span Length	6 ft to 8 ft
Base Plate Dimension	8 in. to 16 in.
Concrete Strength	3,500 psi to 4,500 psi
Concrete Thickness	2.5 in. to 4.5 in.

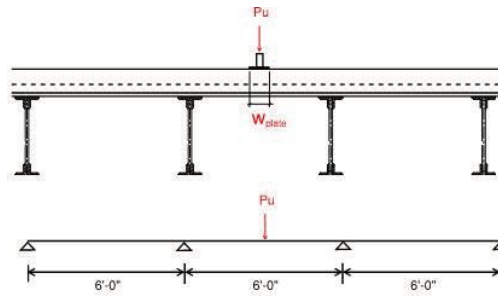

- Properties:
- Concrete strength f'_c = 3500psi
 - Deck strength F_y = 50ksi
 - Deck thickness = 18GA
 - Deck Type = Inverted 1.5"
 - Slab thickness = 3.5"
 - Span = 6ft
 - Base plate Width = 8in
 - WWR = 4"x4" - D9xD9

Fig. 3. Schematics of a point load on concrete slab over metal deck.

Figure 4 presents the impact of each limit state on the point load capacity with respect to each design variable. As span increases, the point load capacity is always governed by a negative bending limit state. The same trend is observed as the base plate dimension and concrete strength vary. However, as the slab thickness over the metal deck flute increases, the governing limit state changes from negative bending to one-way shear. This can be understood by considering that increasing the concrete thickness can greatly increase the one-way shear capacity of the composite slab but not as much as the flexural capacity. In addition, the figure indicates that varying the base plate dimension and slab thickness can have a significant impact on the ultimate capacity.

Deck Point Load Charts

Based on the methodology presented above, easily determining the point load capacity given the design information, without the need to look deeply into each limit state individually, is a worthwhile goal. Designing composite floor deck slabs involves a number of design parameters, and previous sensitivity analyses indicate that the variables that have the most significant effect on point load capacity are base plate dimension and slab thickness. Additionally, different metal deck profiles will produce different capacities. Here, three types of profiled metal deck are considered: inverted 1.5-in. deck, 2-in. metal deck, and 3-in. metal deck. Three concrete thicknesses over the deck flute are considered: 2.5-in., 3.5-in., and 4.5-in.

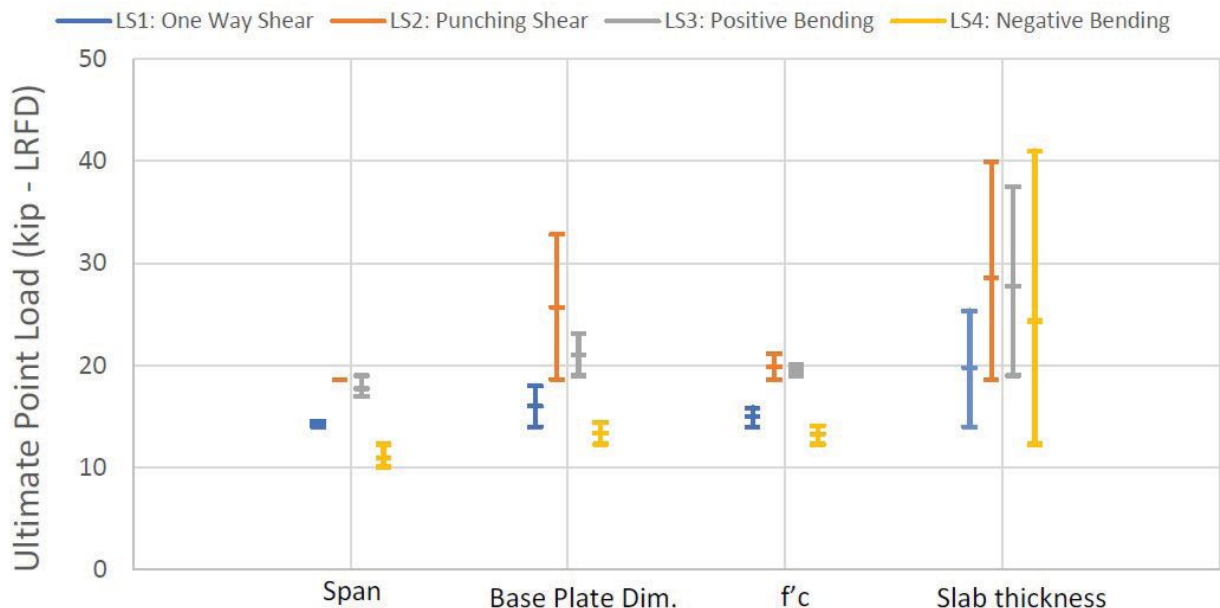

Fig. 4. Sensitivity of design variable and limit states on deck point load.

Base plate widths vary from 6 in. to 24 in. with every 2-in. increment. Other design variables, including concrete strength, WWR ratio, metal deck thickness, and span, are assumed constant and follow the information shown in Figure 3.

We developed a worksheet to determine the point load capacity considering all limit states, and a cluster of point load capacity results was obtained considering all possible combinations of the main design variables for each deck profile. Subsequently, second-order regression

analysis was performed to create a large amount of data where contour lines with constant point loads are then generated. Figure 5 presents the ultimate point load capacity (LRFD) contour line for three different types of metal deck with 5 kip of point load increment (for clarity, the simplified structural analysis model appears at the top of the chart). In this chart, horizontal axis is the dimension (width) of the base plate that supports the load, and vertical axis is the slab thickness over the metal deck flute. In the figure, solid lines, dash

lines, and dotted lines represent the contour plot of composite floor using inverted 1.5-in. deck, 2-in. deck, and 3-in. deck, respectively. Linear interpolation can be applied if the result lies in between, and the superposition method can be applied if multiple point loads are imposed within the same middle span. From this chart, you can quickly estimate the deck point load capacity instead of going through a complete design check process.

Due to floor openings, beam members might not be equally spaced. In this case, the force required for the deck to carry is distributed differently compared to an equal span scenario. We considered an unequal span configuration where edge spans are 4-ft, 7-in. long and the middle span is 9 ft, 3 in. Figure 6 presents the point load capacity with unequal spans.

Adjustment Table

The two previous charts assumed that several other parameters would remain the same, including concrete compressive strength (f_c), span length, WWR rebar ratio, the location of the point load (edge span vs. middle span), and the number of spans considered. In practice, variations of these parameters would occur and affect the final capacity. To address this, we performed additional analysis, and Table 2 summarizes the effect of each variation by introducing an adjustment factor. This factor is a ratio of the point load capacity from a “varied” scenario to that of the baseline case indicated in Figure 5. As seen in the table, an increase of concrete strength by another 500 psi would increase the capacity by about 5% to 10%. If the span is 7 ft (1 ft longer than 6’ ft), then the final capacity would be reduced to 0.85 to 0.9 of the baseline case. This can be understood by considering that bending moments can be increased and thereby limit the point load carried. With regard to WWR rebar area, it can increase the capacity by up to 5%. If the concrete slab is not thick, negative bending is a governing limit state, as indicated in Figure 4. Therefore, increasing the rebar area would help increase the capacity. Once concrete thickness increases so that one-way shear becomes the controlling limit state, increasing the rebar will not contribute to any increase in capacity. Also, placing the point load to the edge span

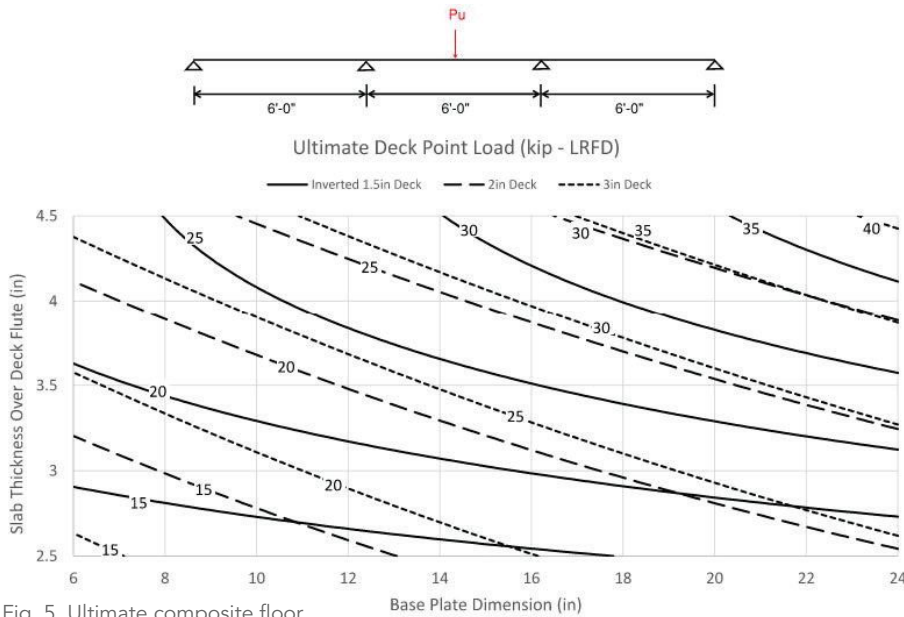

Fig. 5. Ultimate composite floor point load capacity (equal span).

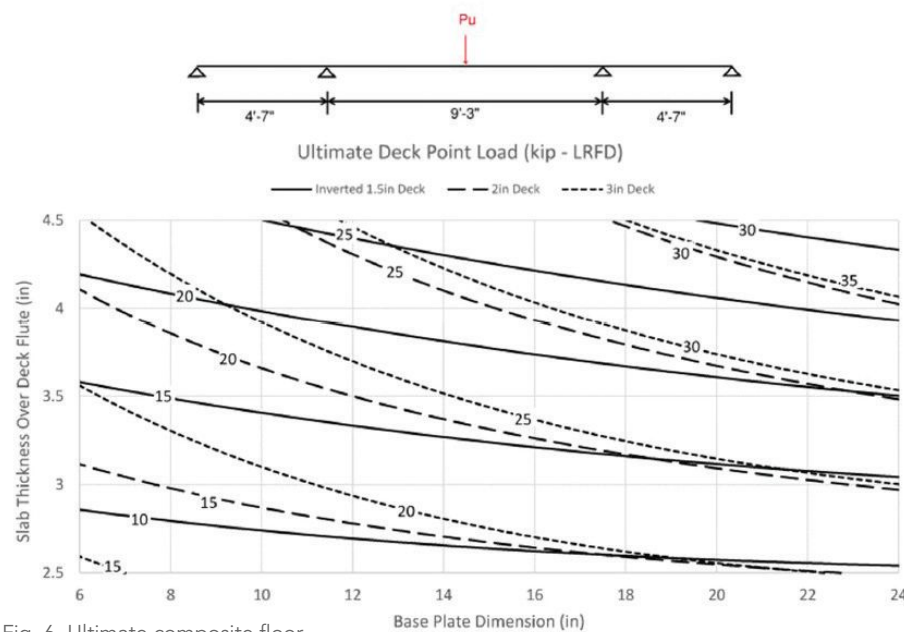

Fig. 6. Ultimate composite floor point load capacity (unequal span).

Table 2. Correction Table

Design Variable	Variation	Modification Factor
f'c	+500 psi	1.05 – 1.10
Span	+1ft	0.85 – 0.90
Rebar	+20%	1.00 – 1.05
Location	end span	0.80 – 1.00
Number of span	+1 span	1.00 – 1.02

will potentially decrease the capacity. This is because maximum positive and negative moment is greater when the point load is at the edge span, as there is only one adjacent span that provides rigidity to resist the load. However, once the one-way shear limit state governs, placing the load in the edge span or middle span would not make any difference. Additionally, the capacity is slightly increased if an additional span is considered in the analysis.

Determining the point load on a composite floor deck is important for industrial buildings. By creating a systematic calculation worksheet and performing regression analysis, we've attempted to simplify the process by creating two ready-to-use lookup charts for point load capacity considering different deck profiles and span information, as well as an adjustment table to address variation in other important design variables. ■



Rafik Gerges (rgerges@hsaassociates.com) is a principal and **Weian Liu** (weian@hsaassociates.com) is a senior engineer, both with HSA and Associates, Inc.

Design Examples

To test the resources mentioned in this article, we've provided three design examples.

Example 1. A composite deck made of 2-in. metal deck topped with 4-in. concrete was designed to support equipment with a weight of 10 kip on a single 10-in. by 10-in. base plate. The relevant gravity framing and composite deck information are shown in Figure 3. Would the deck be considered adequate?

As indicated in Figure 7, the ultimate point load capacity is around 22 kips by interpolation, which is greater than $1.6 \times 10 \text{ kip} = 16 \text{ kip}$. Therefore, $DCR = 16/22 = 0.73$, so the answer is yes.

Example 2. A composite deck made of inverted 1.5-in. deck topped with 3.5 in. of concrete was designed to support an ultimate load of 15 kip (gravity beams are spaced unequally as shown in Figure 6 and the rest of the information following Figure 3). What would be the minimum required base plate size?

Looking at Figure 6, inverted 1.5-in. deck with an 8-in. base plate would have an ultimate point load of 15 kip. Therefore, the base plate must be a minimum of 8 in. wide.

Example 3. For the platform system and loads shown in Example 1, if the span is 7 ft instead and the post is located at the end span, would the deck be considered adequate?

According to Table 1, two adjustment factors need to be considered—namely 0.8 for the end span and 0.85 for the longer span. Therefore, the current ultimate capacity is $0.8 \times 0.85 \times 22 = 14.96 \text{ kip}$ and $DCR = 1.6 \times 10 / 14.96 = 1.07$. Therefore, the current design is not adequate.

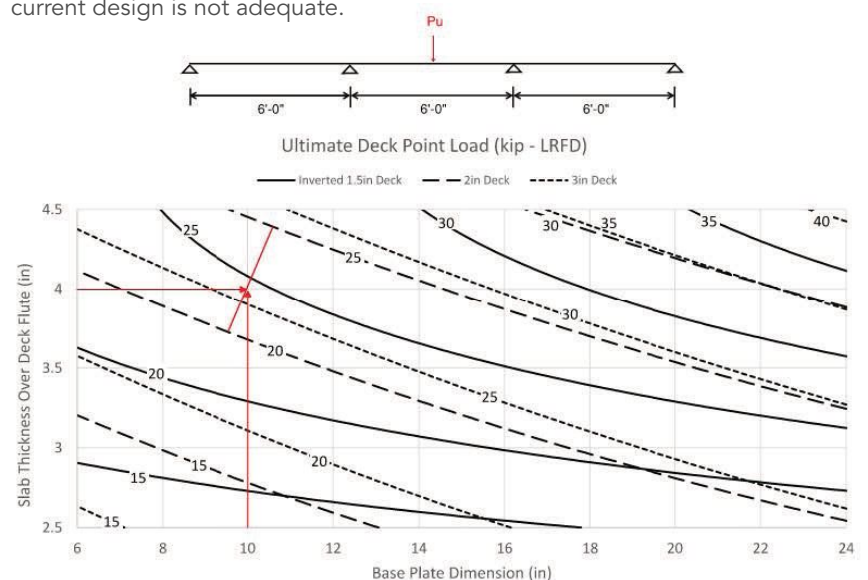

Fig. 7. Ultimate deck capacity lookup for Example 1.

Certified Quality

BY JOE DARDIS

More and more steel fabricators and erectors—as well as the companies who employ them—are seeing the benefits of AISC certification. And it’s easier to find them now, more than ever.

WHAT DOES IT MEAN to be an AISC certified facility?

Simply put, it proves that a facility has the personnel, organization, experience, procedures, knowledge, and equipment to perform quality fabrication and erection. AISC certification sets the quality standard for the steel industry and lowers project risk by focusing on error prevention rather than error correction. For a project owner, designer, or contractor, an AISC-certified facility is the type of facility you want working on your next project.

AISC currently offers eight different types of certification and seven different endorsements (see Figure 1), ensuring that certified facilities can cover a wide breadth of project types and complexities. Whether the project is a small building with a basic framing system, a long-span bridge in a high-seismic zone, or a grand lobby with ornate architecturally exposed structural steel (AESS), AISC certification demonstrates to all involved parties that a fabricator or erector is up to the challenge and has proven its abilities.

If you’ve ever had trouble locating an AISC-certified fabricator or erectors in the past, you may want to take a second look. The number of facilities becoming certified or gaining special endorsements has grown substantially in the last several years (again, see Figure 1). In fact, since 2015, the number of certified building fabricators has increased by 25%, and the number of certified erectors has increased by a whopping 81%!

It’s certainly a good thing for the U.S. steel industry—not to mention project owners and teams—to have more certified facilities, but you may be wondering how this works on a regional basis—i.e., are there many certified facilities near me or will I need to search farther afield for one? While it’s not uncommon for fabricators and erectors to do work away from their home base, most will operate within a loosely specified geographical area. The good news is that, as indicated in Figure 2, we can see that all regions saw significant increases in certified facilities—further proof that AISC certified facilities can be found anywhere in the U.S.

But don’t just take our word for it. AISC recently launched an interactive certification search database with mapping functionality (certification.aisc.org/map.aspx). Users can select whatever certifications are

	Year						
	2015	2016	2017	2018	2019	2020	2021
Building Fabricator	819	866	904	929	952	982	1,026
Bridge Fabricator							
Simple	152	151	152	154	153	152	152
Intermediate	71	77	75	79	78	77	82
Advanced	74	78	80	77	78	81	82
Highway Component Manufacturer	134	146	164	170	186	193	204
Hydraulic Fabricator							
Standard	2	3	9	19	25	27	25
Advanced	0	0	0	0	0	0	8
Erector	247	263	311	347	377	410	447
Fabricator Endorsements							
Complex Coating – Enclosed	180	191	191	194	195	196	197
Complex Coating – Covered	50	46	49	50	53	52	53
Complex Coating – Exposed	8	8	8	8	7	7	9
Fracture Control	127	138	137	137	140	142	150
Erector Endorsements							
Metal Deck	0	33	163	194	204	217	240
Bridge	1	14	43	42	46	49	58
Seismic	0	15	75	79	73	70	75

Fig. 1.

	Building Fabricator	Erector
Northeast	14%	58%
Midwest	20%	84%
South Atlantic	22%	81%
South Central	38%	100%
West	30%	98%

Fig. 2.

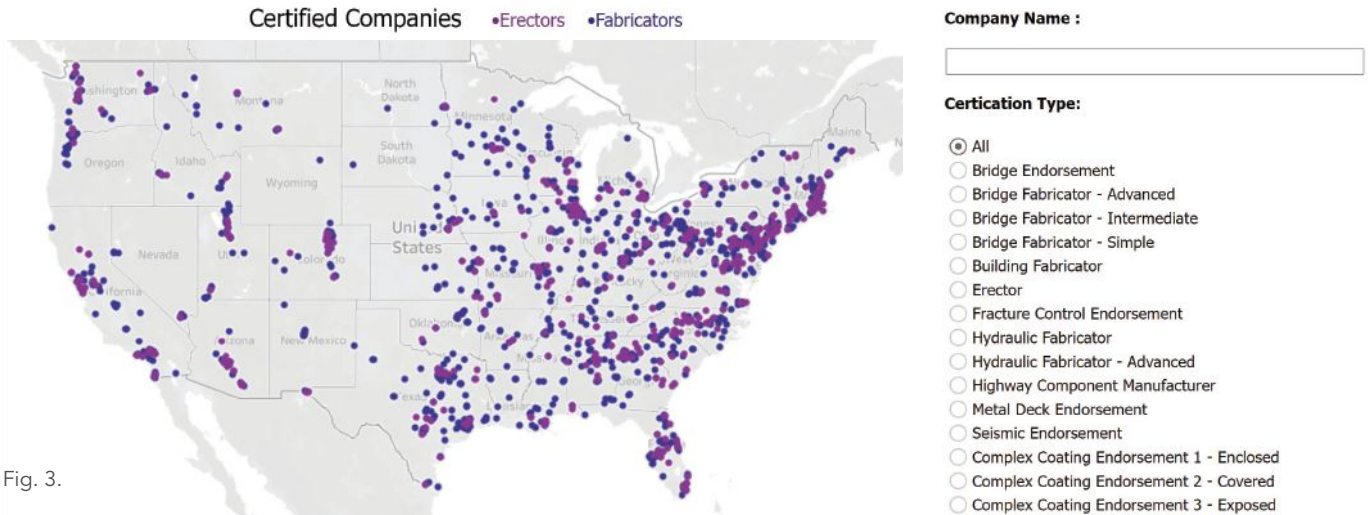

Fig. 3.

needed for a project, get a map view of all certified facilities, and zoom in to get a more detailed regional view with a company list. They can also search for a specific company to see if its facility is certified. (See Figure 3).

As the number of certified

facilities continues to grow, there is no reason to take unnecessary risks on your next project. AISC certification is the quality standard for the structural steel industry, and finding a certified fabricator or erector for your next project has never been easier. ■



Joe Dardis
(dardis@aisc.org)
is AISC's senior structural steel specialist for the Chicago market.



"It easily doubles our output – no mistakes"
Plant Manager • Papp Iron Works

One current customer's team can layout 26 stair stringers in 58 minutes and ended up purchasing another machine for their second location.



603-402-3055 • Automated Layout Technology™
Visit AUTOMATEDLAYOUT.COM for a Quote

The first automated marking machine created specifically for the **layout of commercial handrails, stair stringers** and so much more utilizing your steel detailer's dxf files.

- Cut Fabrication Time by More Than 50%
- Ensure the Highest Level of Accuracy
- Boost Your Profit Margins!
- Lay out complex geometry in seconds
- Designed to replace your existing fabrication table



"The guys love it. They jumped right in on it and have been working to make the most use of it. Great purchase."
Nat Killpatrick • Basden Steel Corporation

"I think it's fair to say that this machine continues to exceed our expectations. We are very happy with it."
Chief Operating Officer • Koenig Iron Works

"The machine is fantastic and could not be happier. Keep selling this machine, it's a winner."
Misc. Shop Foreman • Koenig Iron Works

The Long Run

INTERVIEW BY GEOFF WEISENBERGER

University of Illinois engineering professor Larry Fahnestock takes a proactive approach to teaching, advising, and covering great distances.



LARRY FAHNESTOCK didn't always know he'd become an engineering professor, but he took the path one stage at a time—much like he does when he's participating in triathlons.

His road has taken him from D.C. to Pennsylvania to Champaign-Urbana, where he is currently a professor at the University of Illinois and the Civil and Environmental Engineering Excellence Faculty Fellow in the Grainger College of Engineering. He also received the AISC Faculty Fellowship (now called the Milek Fellowship) in 2009

and served as a judge for this year's AISC IDEAS² Awards competition. Read on to hear about how he became an engineer, then a professor, his teaching methods, his thoughts on mentorship, and his interest in endurance sports.

Can you talk a little bit about where you're from and where you grew up?

I was born in the nation's capital, Washington, D.C., and I lived in Maryland, right outside D.C., for the first 16 years of my life, then headed back to Pennsylvania. That's where my parents were originally from, and I finished high school and completed my time at home with my parents there.

And from there, it was college.

Yes, I went to Drexel University for my undergrad studies, and I was in a dual-degree program in architectural engineering and civil engineering. After Drexel, I went to Lehigh University for my master's degree.

It was my first research experience working in the lab. I did some testing of high-performance steel I-girders, which was one of my early experiences with steel structures.

Why engineering?

I would say that my path to engineering was fairly organic. I didn't have any enlightening moment where I just knew I wanted to be an engineer but growing up, I always enjoyed tagging along with my dad, who was not an engineer by training but was definitely a very skilled technical person and problem-solver, doing projects around the house on cars and computers. And I just enjoyed the kinds of things he did. My mom was a schoolteacher, and I think my initial career inclinations were more toward teaching, maybe math, and I recall my mom suggesting that I take a look at engineering, probably around my senior year of high school when I was first thinking about career options. I



Field Notes is *Modern Steel Construction's* podcast series, where we interview people from all corners of the structural steel

industry with interesting stories to tell.

Listen in at modernsteel.com/podcasts.

found architectural engineering intriguing because I had an interest in buildings, and that was pretty much the way it all started.

Did you go on to get a PhD immediately following your master's degree?

I decided after my master's degree, I'd go into engineering practice, so I worked for two-and-a-half years before I went back to school for the PhD. That was definitely a great idea and a great opportunity for me to see the application of some things I'd been studying and also get some direction for the future.

What made you decide to go into academia?

I feel like a lot of my decisions in life and the paths I've taken have sort of developed in front of me. There hasn't been a big master plan, so I've taken things one step at a time. I definitely enjoyed the work I was doing when I was in practice and gained a lot of great experience there. But I also realized that I enjoyed the academic environment and the different kinds of challenges and growth that come from teaching courses and doing research. And that's what spurred me to return to school and join the PhD program at Lehigh. It was one of those things that just sort of emerged out of the blue. I wasn't really even planning to apply at that point, but I talked to my advisor, who mentioned an opportunity to join a project, and it sounded interesting and I was ready for a change at that point. And so that led me back to school. And after that, I took a position at the University of Illinois at Urbana-Champaign.

Can you tell me what it was like getting up in front of a class on your first day as a professor?

It was definitely an intimidating feeling being a brand-new faculty member and not being a whole lot older than the students. I remember my department head at the time, Bob Dodds, came in and said a few words of introduction. Then he left the room, and I was on my own. I had a little bit of teaching experience as a grad student, so I knew a little bit about what it was like to get up in front of a class, but I found the experience invigorating.

I'll bet! Fast-forwarding from your first day of teaching, I understand that you served as an Education Innovation

Fellow in the University of Illinois' Grainger College of Engineering during the 2013-2014 academic year. I was just curious what that entailed.

For starters, let me say that it's been a great pleasure to work in a college that really values doing new things in the educational realm. And the college here has a long-running program that encourages new concepts in the classroom and funds new initiatives. During that year, I piloted some new things in my undergraduate steel design course, where I worked on flipping the classroom and using a new format there that I hadn't done previously. This involved delivering content to students before they formally arrived in class. I recorded a series of short pre-lecture videos that the students would watch before they came to class. That way, they get the main concept for the day before they even arrive, and then they can jump right in when they get to class. But even more importantly, it opens up more time in the classroom for interactive activities or project-based learning. The idea is to make the educational experience more interactive for the students, which has been shown to be a more effective way to teach the material and engage them.

That sounds like a great approach. On a related note, you've also received a few other awards at the University of Illinois related to advising and mentoring. And I was curious if you could talk a bit about your philosophy on mentoring students.

I'd say my philosophy on mentoring is very simple: Make time for students, care about them and their individual needs and concerns, and try to help them sort out things that they're thinking through as they're developing their plans for the future. I don't necessarily have any great insight or wisdom, I just try to listen well, share my own experiences, and give them sound advice. I feel like I take a fairly basic approach, but I think that students have seen that I do care about them and that I'm willing to take the time to help them sort through what they're facing. And I think they appreciate that.

Switching gears a bit, you were a judge for our 2022 AISC IDEAS² Awards, which focus on the integration of architecture and engineering. In addition to this year's winners, can

you point to any steel buildings that you think do a particularly good job of illustrating the successful integration between those two disciplines?

We actually have a building here on campus that's very new and is very nicely done. It's called the Campus Instructional Facility, and it's just around the corner from my building on campus. It was designed by Skidmore Owings and Merrill, and they have a rich history of integration between architecture and engineering. It's got nice exposed structural steel throughout the building, including the braced frames and some exterior steel. It incorporates brick masonry on the façade, which relates to the more traditional campus architecture, but it has a really nice presence—and inside, it's a very airy open, light building, a nice place for people to gather. It's a new addition to campus, and I'm looking forward to using it more in the years to come.

Tell me about one of your outside interests.

I enjoy endurance sports like running and cycling. I've done a number of road races, more in my earlier adult years, and ran some marathons. I don't get in as many miles as I used to, but more recently I've started doing some shorter-distance triathlons. I've done a sprint so far, and I'd like to try to do the Olympic distance sometime, but I'm still working on my swimming. It's my weak leg. ■

This column was excerpted from my conversation with Larry. To hear more from him, including details on his research and his thoughts on Champaign-Urbana, check out the May Field Notes podcast at modernsteel.com/podcasts. And to read about this year's IDEAS² Award winners, turn to page 28.



Geoff Weisenberger (weisenberger@aisc.org) is chief editor of *Modern Steel Construction*.

Hitting Reset

BY DAN COUGHLIN

If a conversation starts to get ugly, remember to step back, be mindful of what's happening below the surface, and hit the reset button.



HAVE YOU EVER NOTICED how you can have a pleasant, enjoyable conversation with a person one day, and then the next day get into an intense, highly emotional, negative conversation with that very same person?

How is that possible? The same two people are talking. How can it go from pleasant one day to unpleasant the next? (And to be clear, I'm talking more about work relationships and acquaintances, not necessarily romantic relationships or close friendships. While abrupt shifts in tone can and frequently do occur with friends, spouses, etc., those types of relationships come with more "history" and emotion.)

The key is what's happening on a deeper level for each person. If it was just the surface of the water both times, then you would expect to have the same interaction. However, it's what is happening below the surface that impacts the interaction. It's not necessarily anything that the other person is saying or doing that caused the conversation to get so ugly. It could very well be what is happening inside of you.

If you're bringing exhaustion, stress, frustration, anger, worry, or fear into an interaction with another person, then it's

eventually going to make its way to the surface—even if those emotions are related to something completely different. Or, it might be that you're bringing negative judgments about or unrealistic expectations of the other person into the conversation, and then those will impact the interaction. Either way, the conversation can turn ugly before you know it.

Resetting Your Mindset

This is where a mental reset can be beneficial. Barbara Frederickson, a professor of psychology and principal investigator of the Positive Emotion and Psychophysiology Laboratory at the University of North Carolina at Chapel Hill, wrote a tremendous book called *Positivity: Discover the Upward Spiral that Will Change Your Life*. It's a great read (especially Chapters 1, 2, 3, 9, 10, and 11) and provides a wide array of useful and practical ways to reset your mindset to a positive attitude. Here are five of my favorite insights from her:

Let go of gratuitous negativity and stop ruminating. I think this is a home run of an idea. I never thought of being negative as being gratuitous, but as soon as I read that, it hit home with

me. Sometimes I can hang on to a negative thought about a situation or another person like I was savoring a fine meal. I bring it back up to a level of conscious awareness several times a week.

Frederickson shows how incredibly unhealthy that is for any of us to do. The key is to stop ruminating. Ruminating is when we go over and over our negative thoughts and feelings and bring them to a fever pitch. Now, when I'm about ready to experience gratuitous negativity, I say to myself, "Stop ruminating." That one tip alone has allowed me to step into conversations with a much healthier mindset.

Go through a mental list of all things you appreciate about the person you are speaking with. If you find yourself getting emotionally worked up as you step into a conversation with someone, step back and just focus on the things you appreciate about the person. If you can zero in on three things that the person does that you are grateful for, then you can increase your chances of having a really good conversation.

Look back at your life with pride and cherish yourself. This was another one where Frederickson caught me

off guard. Usually, I've heard people talk about avoiding self-pride, but she makes a great case for actively being proud of our past. Far too often, we beat ourselves up over the 1% of our life's decisions and behaviors that we are not proud of rather than appreciate the person we were when we made 99% of our positive—or at the very least, unharmed—decisions and actions.

If we beat ourselves up over and over, then we might very well emotionally beat up the other person in a conversation without even realizing it. If we look back at our lives with pride and acknowledge the person we are in our best moments, then perhaps we will be more likely to appreciate the other person we're talking with.

Smile and bring a light touch to the conversation. Think of a great conversation you had with another person. My hunch is you both probably smiled a lot and treated each other with respect. There might have been some good-natured kidding and some genuine laughter. Both

people walked away from the conversation feeling good about themselves.

Notice that I didn't even mention the content of the conversation but rather only described the interaction: smiling, laughter, and a nice tone and pace. No judgments, no expectations, no heavy negative emotions. Just a light touch.

Spend time in nature and focus on blue, green, grass, sky, and water. It can come across as hokey, but nature seems to bring its own vocabulary and emotions to the table. Going for a walk on a pleasant day is a simple but powerful way to allow our negative emotions to dissipate. We can then walk into conversations with a degree of calmness that we won't have if we've worked ourselves to a state of exhaustion and have been ruminating for several hours.

There will always be difficult, emotionally charged conversations—and frankly, those, too, have their times and places—but even in those situations, hitting the reset button here and there can help them end better than they started. ■



Since 1998, **Dan Coughlin** has worked with serious-minded leaders and managers to consistently deliver excellence. He provides Executive Coaching, Group Coaching Programs, and seminars to improve leadership and management performance. His topics are personal effectiveness, interpersonal effectiveness, leadership, teamwork, and management. Visit his free Business Performance Idea Center at www.thecoughlincompany.com.

Dan has also presented several presentations in recent years at NASCC: The Steel Conference. To hear recordings of them, visit aisc.org/education-archives and search for "Coughlin."

VOORTMAN V807 ROBOTIC THERMAL PROFILE PROCESSOR



VOORTMAN USA

26200 S. Whiting Way +1 708 885 4900
Monee, IL 60449 info@voortmancorp.com
United States of America www.voortmancorp.com

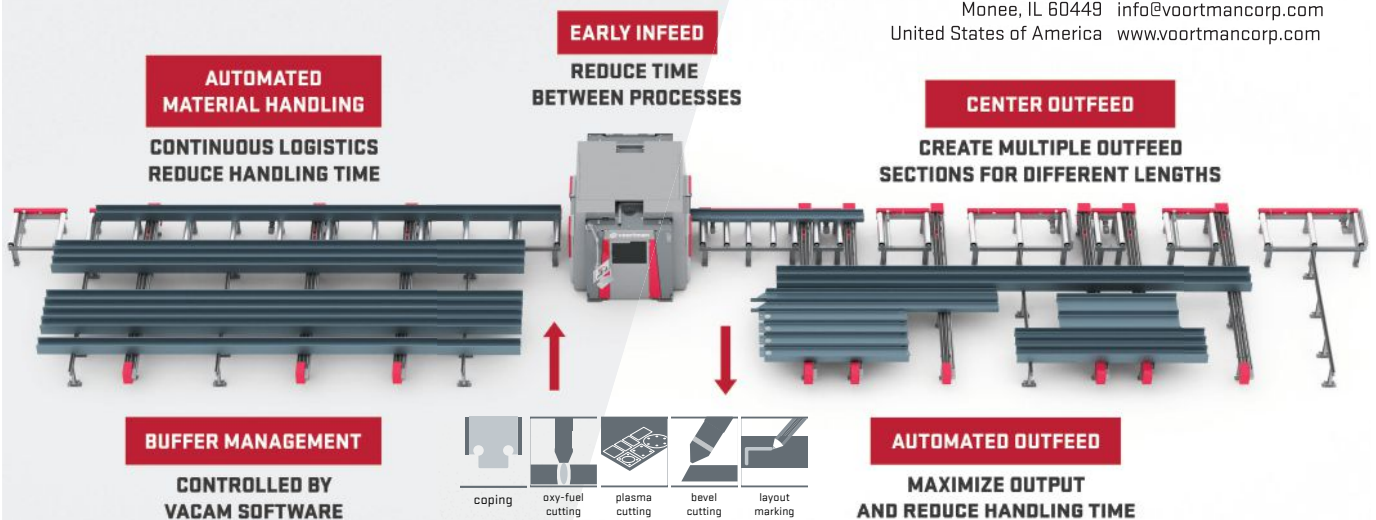

"With multiple output sections, we already sort our profiles according to the output by length or project. This saves us a lot of handling time and we see a faster turnaround in the entire workflow."
David McWhirter of McWhirter Steel

"The early infeed in particular has made a big difference in production speed. In addition, production is fully automated with our operator focusing more on loading and unloading profiles."

Steven Scrape of SCW



Winners Choose Chicago Metal TO Curve Steel



2014 SEAIO Best Project - Elliptically curved trusses rolled from 5" and 8" diameter AESS pipe for Institute of Environmental Sustainability at Loyola University. Chicago, IL

2007 IDEAS² National Winner
- 400 tons of 12" square tubing curved for the retractable, lenticular room trusses at the University of Phoenix Stadium. Phoenix, AZ

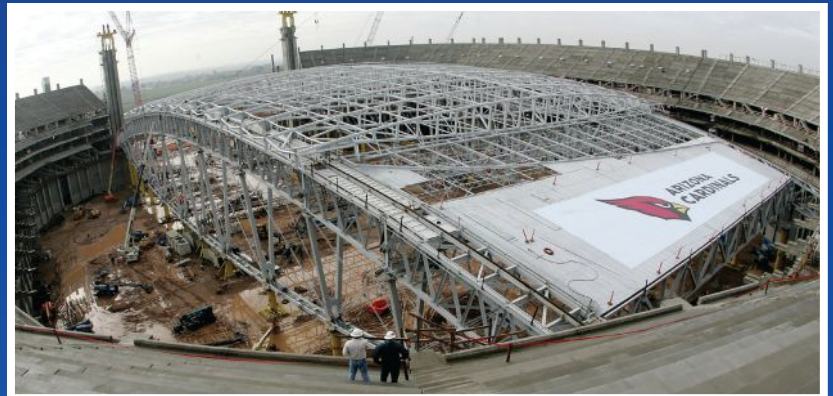

2015 IDEAS² Merit Award - 73 pieces of curved 8" sch 40 pipe totaling 35 tons for Circuit of the America Observation Tower. Austin, TX



2005 EAE Merit Award - 570 tons of 12", 14", 16", 18" and 20" pipe curved for the Jay Pritzker Pavilion. Chicago, IL



2003 IDEAS² National Winner - 300 tons of 5" square tubing curved 45° off-axis for the Kimmel Center. Philadelphia, PA

Call us at 866-940-5739 to make *your* next project a winner!

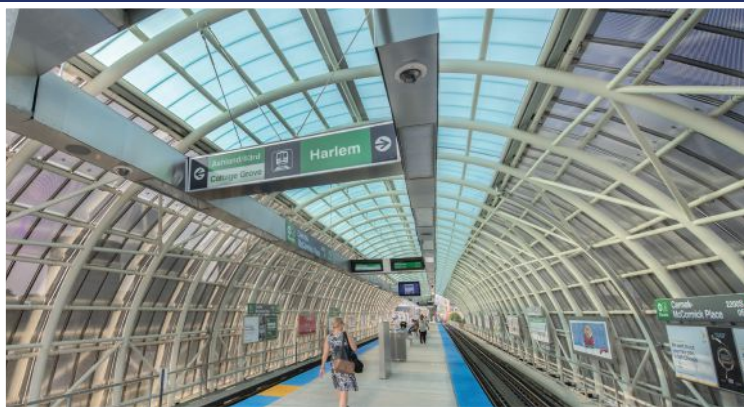

2015 AIA Distinguished Building Award - HSS 8" pipe featuring an ellipse curvature with multi-radius bends for the structural ribs for CTA Cermak-McCormick Place Station. Chicago, IL



2012 IDEAS² Merit Award - 133 tons of 16" pipe curved for the Rooftop Tiara of the Great American Tower at Queen City Square. Cincinnati, OH

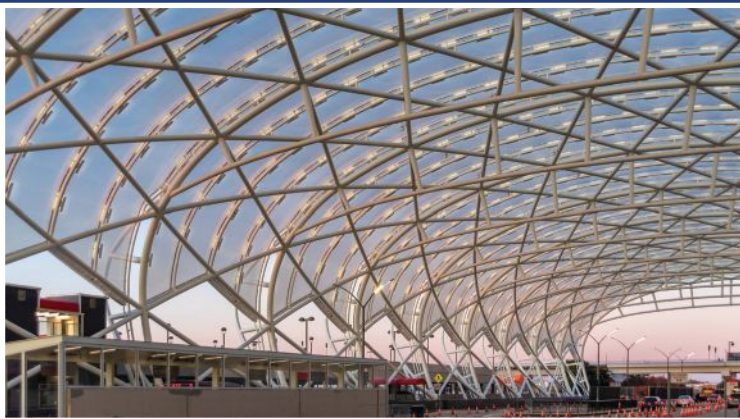

2020 IDEAS² National Winner - 920 pipe members rolled from 1300 tons of 14" pipe creating 38 super-trusses for the iconic canopy at Hartsfield-Jackson Atlanta Intl Airport. Atlanta, GA



2013 IDEAS² Merit Award - 3600 pounds of pipe each curved with multiple radii for a solar canopy to recharge batteries on electrical vehicles. Chicago, IL

2007 NSBA Special Purpose Prize Bridge Award - 152 tons of 18" pipe curved in our Kansas City plant for the Highland Bridge. Denver, CO



2010 NCSEA Award Winner - 200 tons of beams, channels and angle for the roof of the University of Illinois at Chicago Forum. Chicago, IL



**CHICAGO METAL
ROLLED PRODUCTS COMPANY**

CHICAGO • KANSAS CITY

cmrp.com



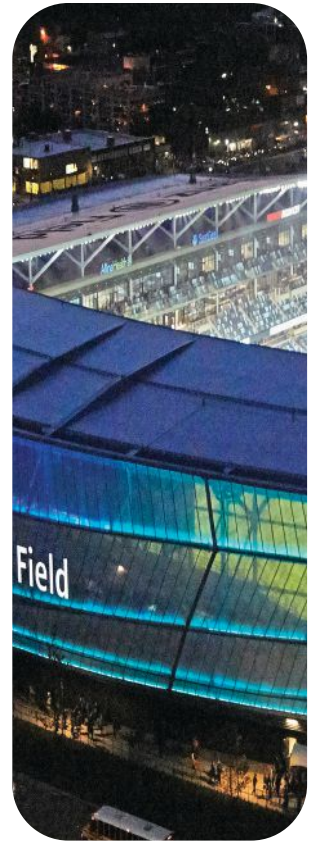

2022 IDEAS² AWARDS

A SEATTLE HIGH-RISE using a first-of-its-kind core system. A staircase that looks like a floating ribbon. A performance venue named for a rock-and-roll pioneer. A museum designed to look like an athlete in motion.

What do they all have in common?

They're all steel-framed. And they're all winners.

Specifically, these four projects, as well as five others, are winners of the 2022 AISC IDEAS² Awards.

Why "IDEAS²?" Because the program recognizes Innovative Design in Engineering and Architecture with Structural Steel. Awards for each winning project are presented to the project team members involved in the design and construction of the structural framing system—including the architect, structural engineer of record, general contractor, owner, and AISC member fabricator, erector, detailer, and bender-roller.

New buildings, as well as renovation, retrofit, and expansion projects, are eligible, and entries must meet the following criteria:

- A significant portion of the framing system must be wide-flange or hollow structural sections (HSS)
- Projects must have been completed between January 1, 2019, and December 31, 2021
- Projects must be located in North America
- Previous AISC IDEAS² award-winning projects are not eligible

This year's judges considered each project's use of structural steel from both an architectural and structural engineering perspective, with an emphasis on:

- Creative solutions to the project's program requirements
- Applications of innovative design approaches in areas such as connections, gravity systems, lateral load-resisting systems, fire protection, and blast protection
- The aesthetic impact of the project, particularly in the coordination of structural steel elements with other materials
- Innovative uses of architecturally exposed structural steel (AESS)
- Advancements in the use of structural steel, either technically or in the architectural expression
- The use of innovative design and construction methods such as 3D building models, interoperability, early integration of steel fabricators, alternative methods of project delivery, and sustainability considerations

The entries were placed in four categories according to their constructed value in U.S. dollars:

- Less than \$15 million
- \$15 million to \$75 million
- \$75 million to \$200 million
- More than \$200 million

Two National honors were awarded in the \$75 million to \$200 million category, and Merit honors were awarded in the More than \$200 million, \$75 million to \$200 million, \$15 million to \$75 million (two), and Less than \$15 million categories. In addition, a Sculptures/Art Installations/Nonbuilding Structures Merit winner was also selected, and one project won a Presidential Award for Excellence in Structural Design.

This year's judging was a bit different than in years past. Instead of having a small panel (typically five or so) judge every category, we expanded the number of judges and split the judging up by category. We also had the submitters of the finalists/highest-scoring projects for each category submit brief videos. From there, National and Merit winners were decided. This year's juries were:

Less than \$15 Million

- Scott Blair, Editor-in-Chief, *Engineering News-Record*
- Barbara Simpson, PhD, Assistant Professor, Oregon State University
- Blair Payson, AIA, Principal, Olson Kundig
- John Kennedy, SE, PE, Principal, Structural Affiliates International, Inc.
- Lisa Patel, Certification Technical Services Manager, AISC

\$15 Million to \$75 Million

- Geoff Weisenberger, Chief Editor, *Modern Steel Construction*, AISC
- Jeffrey Keileh, SE, PE, Project Manager, Plant Construction Company, LP
- David Fennell, Structural Steel Specialist, AISC
- Larry Fahnestock, PE, PhD, Professor and CEE Excellence Faculty Fellow, University of Illinois at Urbana Champaign
- James Puckhaber, AIA, Corporate Practice Leader – Atlanta, The S/L/A/M Collaborative

\$75 Million to \$200 Million

- Monica Shripka, PE, Director of Sales, Marketing, and Business Development, NCSEA
- Raymond Sweeney, PE, Associate, Skidmore, Owings and Merrill
- Negar Elhami, PhD, Associate Professor, University at Buffalo
- Halliday Meisburger, AIA, Associate Partner, ZGF Architects, LLP
- Michael Gannon, SE, PE, Senior Engineer, AISC

Greater than \$200 Million

- Nate Sosin, SE, PE, Vice President, Thornton Tomasetti
- Anthony Massari, PhD, PE, Associate Professor of Practice (Structures), The Ohio State University
- Bruce McEvoy, AIA, Principal, Design Director, Perkins & Will
- Jonathan Tavarez, PE, Senior Engineer, AISC

Sculptures/Art Installations/ Nonbuilding Structures

- Brian Ward, Senior Structural Steel Specialist, AISC
- Scott Melnick, Senior Vice President, AISC
- Rachel Chicchi, SE, PhD, Assistant Professor of Structural Engineering, University of Cincinnati
- Joe Trammell, AIA, JD, Principal, Rule Joy Trammell Rubio
- David Eckmann, SE, PE, FAIA, Senior Principal, Magnusson Klemencic Associates

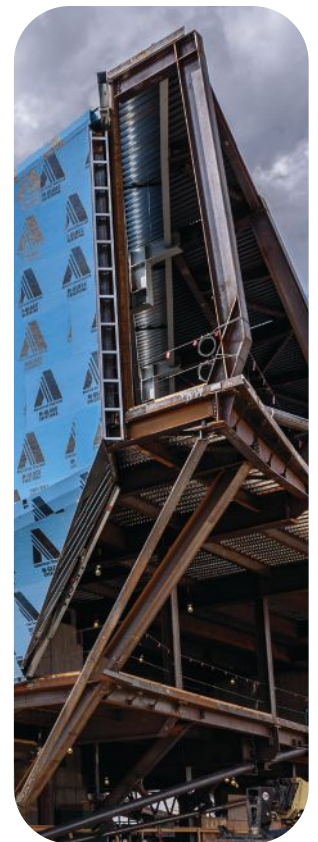



Max Touhey

MERIT AWARD Greater than \$200 Million One Vanderbilt, New York

ONE VANDERBILT stands out above the rest.

At 1,401 ft, it is Midtown Manhattan's tallest office tower. The \$3.3 billion building comprises 1.7 million sq. ft. of office, retail, and amenity spaces while also incorporating \$220 million of transit and open-space improvements.

The building's simple geometry of tapering rectangular volumes integrates the aesthetics of the golden age of high-rise buildings with contemporary concepts of designing for sustainability and enrichment of the public realm. The façade is clad in alternating strips of glass and terra cotta and acknowledges the building's proximity to Grand Central Terminal (right across the street) and other historical buildings. A dramatic fourth-floor cantilever creates a setback through which the Vanderbilt corner of the landmarked terminal can be viewed without obstruction.

Behind the curtainwall stands a frame designed by structural engineer Severud Associates and composed of 26,000 tons of steel. The building features floor-to-floor heights ranging from 14 ft 6 in. to 24 ft, with mostly column-free floorplates and stunning 360° views through floor-to-ceiling windows. The core is a hybrid system of steel framing and high-strength concrete shear walls, which allowed construction manager AECOM Tishman to better control

the schedule (the tower was completed six weeks ahead of schedule, despite the onset of the COVID pandemic during its last six months of construction).

Supported by a concrete mat more than 9 ft thick, the core is augmented by steel outrigger trusses at three intermediate levels that were coordinated closely with the MEP consultant to minimize interference with the building's advanced mechanical systems. Additionally, a steel tuned mass damper keeps accelerations within a comfortable range for building occupants.

Column transfer systems at the fifth and 12th floors give the building its distinctive shape and required floor-deep trusses. By using steel members, the engineers were able to reduce the potential obstruction of chords and interior diagonal members. At truss nodes, forgings were used to make connections as compact as possible while also providing a smooth flow of forces and simplifying fieldwork; forged steel is both isotropic and weldable. In fact, where two or more trusses met at the core, no other type of connection would have been practical.

The efficiency and economy of wide-flange sections made them the first choice for the bulk of the building framing, but box columns and built-up plate girders were used where loads exceeded

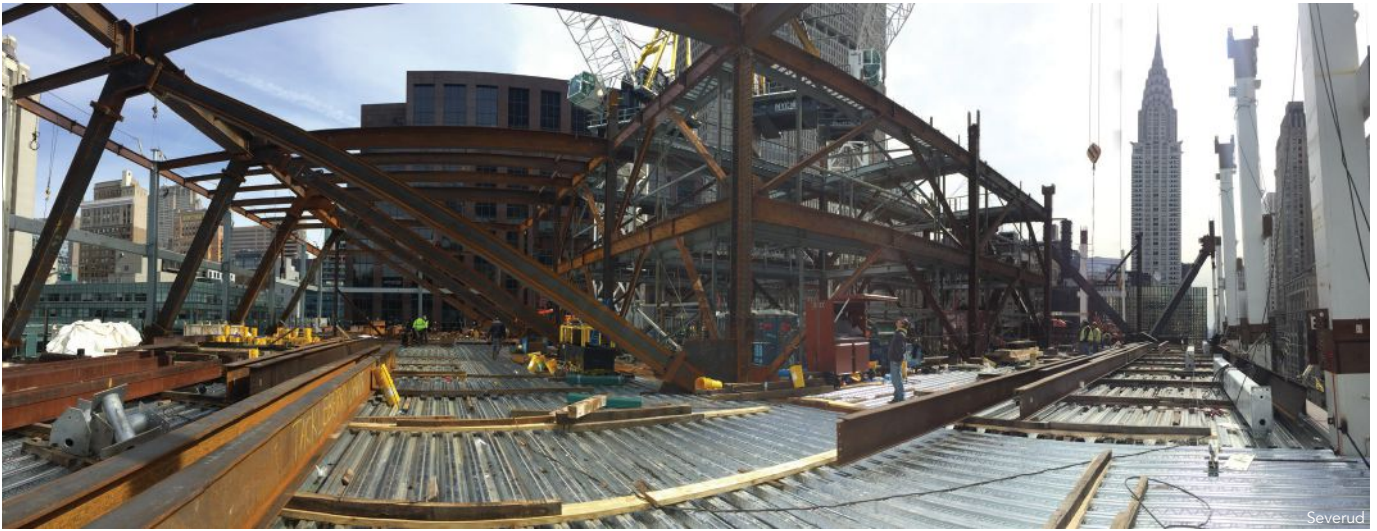
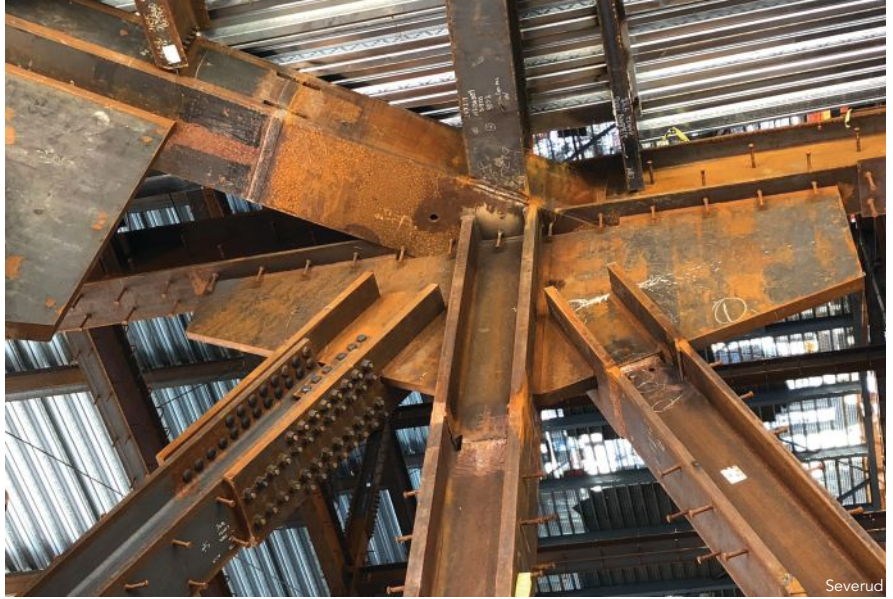

the capacity of rolled members. The availability of plate with different thicknesses and widths coupled with readily adaptable welding details allowed the design team to create sections that could accommodate any geometrical constraint.

At the top of the building, where the “crown” and “snorkel” elements define the upper ends of the building’s tapering rectangular volumes, hollow structural sections (HSS) were the clear choice to support the ins and outs of the curtainwall. Their high capacity in bending—even for large aspect ratios and long unbraced lengths—and their affinity to shop-welded connections simplified fabrication. In addition, field-bolted end-plate splice connections, used for the horizontal and diagonal members, greatly facilitated erection.

Capping everything off is a 128-ft spire, also constructed of steel plate, atop the snorkel. The spire was fabricated in shippable segments with flanged connections that were easily bolted at the lofty height of 1,401 ft. (Glass was considered for the infill panels, but it could not withstand the heat generated by the nearby exhaust flues.) A separate wind tunnel study determined wind loads and forces and the interaction of the spire with the building frame. As a result, diagonal stiffeners were added to each face of the spire to disrupt wind flow and help control icing. As a bonus, the stiffeners continue the architectural effect of directing the eye skyward to the very top.

The tower employed a steel-first erection sequence pioneered by Severud. Columns, girders, and lateral bracing at the core were designed to stand alone to a maximum height of 12 stories. As steel erection proceeded, reinforced concrete shear walls were placed below. Using a self-climbing form system within the core and hand-set forms from outside, concrete work followed





the structural steel up the building, usually within six floors from the top. This approach allowed construction manager AECOM Tishman to absorb potential delays in concrete placement while maximizing the impact of speedy erection times on the overall schedule.

The core walls—the primary component of the lateral force-resisting system—are 30 in. thick with compressive strengths up to 14,000 psi; grade 80 steel reinforcement was used throughout. Controlling lateral drift and motion is especially critical to the performance of supertall buildings, so the concrete shear walls are augmented by steel outrigger trusses at three intermediate mechanical levels.

The entire lateral system was designed based on parameters established by RWDI, the project’s wind tunnel and micro-climate specialist. In response to their analysis of occupant comfort, a tuned mass damper was added near the building’s peak to keep accelerations within comfortable limits. Due to vertical space constraints, a complex system of two steel masses was devised: one hung from above, the other supported on the floor, and each tied to the other to extend the range of vibration frequencies.

After the column transfer systems at the 5th and 12th Floors were erected, optical targets were installed at critical locations on the framing. As erection proceeded, the targets were surveyed from the Chrysler Building and other neighboring towers to confirm behavior and inform the erection process farther up the building, for example, the need for shims at column splices.

For more information on One Vanderbilt, see “Super Fast, Super Tall” in the March 2021 issue in the Archives section at www.modernsteel.com.

Owner

SL Green Realty Corp.

Construction manager

AECOM Tishman

Architect

KPF

Structural Engineer

Severud Associates Consulting Engineers, PC

Steel Team

Fabricator/Detailer

Banker Steel Co., LLC 

Forged Steel Fabricator

Ellwood Specialty Steel

Erector

NYC Constructors LLC 



Steve Bergerson

NATIONAL AWARD \$75 Million to \$200 Million
Allianz Field, St. Paul, Minn.

MULTIPLE ITERATIONS of professional soccer have existed in Minnesota since the 1970s. However, the state never boasted a dedicated Major League Soccer (MLS) stadium.

That changed in April 2019 with the opening of Allianz Field in St. Paul, the new home of Minnesota United FC.

The team's ownership desired a world-class stadium that would also as an iconic piece of art and architecture for the team and state, a venue that would dynamically convey the energy of the play on the pitch to viewers outside and allow them to see into the stadium. It also needed to appear light, airy, and transparent yet still capable of standing up to the harsh Minnesota winters. Architect Populous' design response is defined by a translucent skin wrapping around the entire stadium, made asymmetric and sinuous to avoid the horizontal "wedding cake" look of many traditional stadiums, and supported by large-diameter round hollow structural steel (HSS) shapes.

Meeting this vision required an innovative digital design process that used a common central geometry file for structural analysis, architectural design, and ultimately material fabrication. The common platform enabled near-real-time design iterations between all parties working as one project team, not individual firms. Using a common platform allowed for rapid 3D visualization enabling more informed and timely decisions to be made that were in the best interest of the project as a whole.

Walter P Moore integrated the structural frame analysis and fabric membrane analysis, which allowed for the optimization of the entire structural steel system. The integrated design captured the undulating geometry, varied loading conditions, and complex interface between materials resulting in an extremely cost-effective design without compromising the ambitious design vision. And a

structural steel package totaling 4,500 tons was the easy, economical choice for the primary and secondary structure due to a variety of factors: lack of repetition, long cantilevers, irregular geometry, and schedule.

Complementing the façade, a large canopy protects fans from unpleasant weather while leaving the pitch open to the elements allowing fans a true open-air stadium experience. A variety of canopy shapes and types were considered early in the design process, including a tensile fabric canopy, cantilevered truss, and a cantilevered propped girder system. Ultimately, the propped girder system was chosen as the most economical system for the size of canopy desired. The resulting 145,000-sq.-ft canopy covers approximately 85% of the seats, simultaneously protecting fans from the elements and reflecting sound onto the pitch below.

Structural steel framing creates a light and graceful support of the large canopy while having sufficient strength to support the large snow loads typical of a Minnesota winter. A 3-in. steel deck spanning 13 ft was used to minimize the number of purlins supporting the canopy. Each purlin frames into a large wide flange girder at each gridline, at a 42-ft, 8-in. bay width. The girder cantilevered out 78 ft from the back-of-bowl column and is supported by a single strut that props the girder up. Although this results in a slightly heavier system than a cantilevered truss due to additional bending imposed on the girder, it creates a much more open structure and has fewer pieces to fabricate and erect. At the leading (inner) edge, the girder tapers down from 36 in. to 16 in., matching the depth of the steel purlins creating a consistent thin profile around the stadium. At the north end of Allianz Field, the canopy gracefully swoops down, lowering the overall profile of the stadium.

For the signature feature—the building skin—Walter P Moore partnered with Saint-Gobain to develop a new polytetrafluoroethylene (PTFE) fabric that provided both strength and transparency. In order to minimize cost, the fabric needed to span as far as possible between support lines, which induces large bending loads in two directions along those support lines. Simultaneously, those support lines needed to curve around the stadium, creating the desired architectural appearance. Round 18-in.-diameter HSS provided the ideal support system. These sections, dubbed “driver pipes,” serve to “drive” the skin’s complex geometry and create the supporting structure that gives the skin its distinctive form.

The PTFE fabric was connected to a continuous aluminum extrusion that was then connected back to the driver pipes through a built-up, tee-shaped plate assembly at 18 in. on center. To provide additional tolerances, the plate had four slotted holes at a 45° angle in each corner, which allowed the aluminum extrusion to move vertically or horizontally to maintain proper alignment. The driver pipe connection back to the column assembly was through an endplate to resolve the bi-axial moments and large axial loads. The connection used slip-critical bolts in oversized holes allowing the diver pipe to be adjusted during erection into its precise final location.

In addition, Populous desired the exterior skin to appear continuous without any noticeable joints. Achieving this vision required eliminating expansion joints from the driver pipes. The result is that the driver pipes act as a giant rubber band encircling the stadium. They expand and contract with changes in temperature, resulting in substantial loads within the driver pipes. The structural team took advantage of the natural breaks in the stadium seating bowl corners to allow the seating bowl and west premium tower to breathe naturally. This approach transfers most of the large thermal stresses from the driver pipes into a select few corner columns resulting in a far more efficient structural system.

To achieve the owner and architect’s ambitious vision, Walter P Moore’s structural and enclosure teams knew traditional design and coordination techniques would not be sufficient. The critical innovation was the common digital data platform shared by the structural and architectural design teams and, ultimately, the steel fabricator. During the design process that began in 2015, Walter P Moore and Populous developed a digital workflow to incorporate complex architectural geometry into structural models rapidly and communicate back the impacts in quick turnarounds to modify the architectural design. This created a symbiotic relationship between



Justin Barton



M A Mortenson Company



M A Mortenson Company

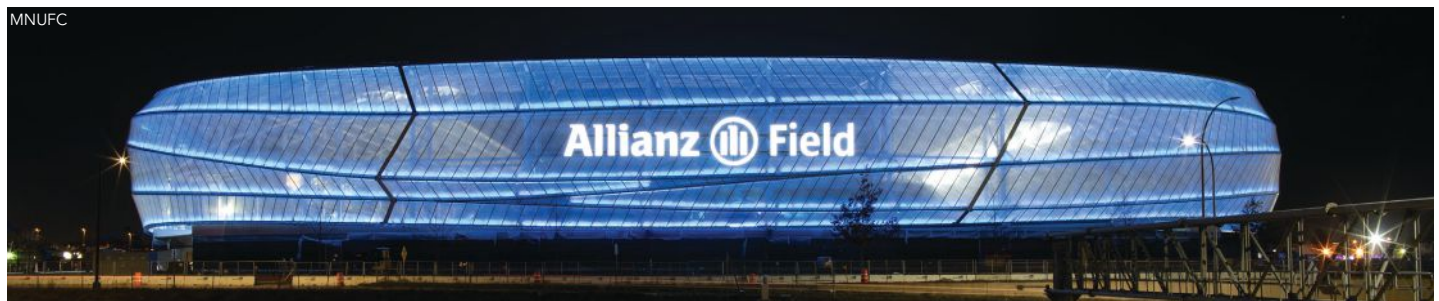

MNUFC

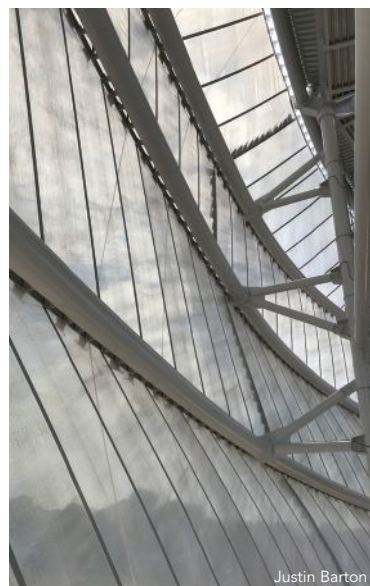

design, analysis, and performance. Essentially, this equated to having a single file in which all parties were accessing, processing, manipulating, and rapidly sharing the data, which enabled quick decision making and led to an efficient system within the time and budget constraints. The numerous iterations of the overall geometry optimized design aesthetics and cost efficiency simultaneously.

Another innovation took advantage of steel fabricator Merrill Steel's trucking equipment and proximity to the job site (180 miles). The canopy girders/struts were fully fabricated in the shop, painted, shipped to the site, and then erected as a single piece to sit directly on the building columns. The longest canopy-plus-back-span piece shipped to the site measured 110 ft long (78 ft cantilever plus 32 ft back span), 19 ft deep, and 23 tons. Due to the preassembled shop fabrication of the canopy, two canopy girder/strut assemblies were erected per day. The entire 145,000-sq.-ft canopy was erected in just 18 weeks, including the erecting in the harsh months of January and February. Assembling the full girder/strut allowed for aesthetically pleasing welded connections to be used. Additionally, it allowed a higher quality paint system, without field painting or field bolting of surfaces, that will increase the longevity of the paint and steel system.

For more information on Allianz Field, see "Soccer Star" in the July 2019 issue in the Archives section at www.modernsteel.com.

Owners

Minnesota United FC
The TEGRA Group

General Contractor

M.A. Mortenson Company

Architect

POPULOUS

Structural Engineer

Walter P Moore

Steel Team

Fabricator/Detailer

Merrill Steel 

Erector

Danny's Construction Company 

Bender/Roller

Max Weiss Company 

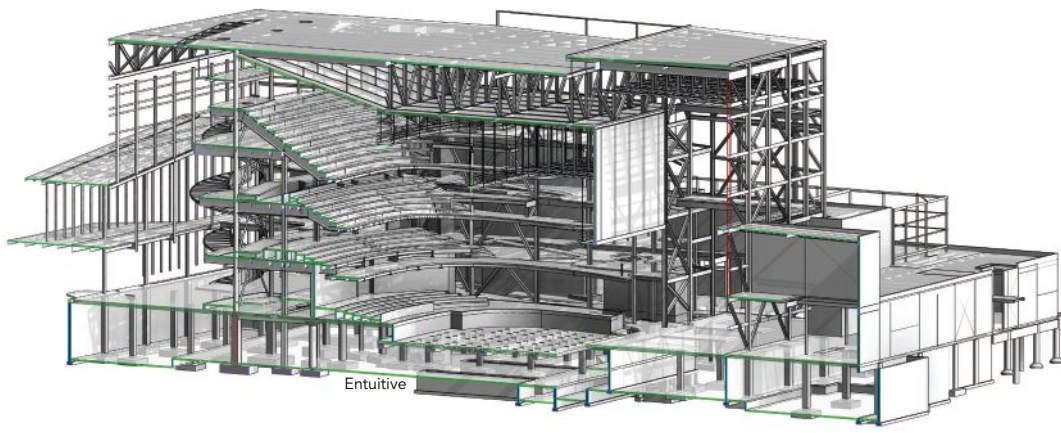

NATIONAL AWARD \$75 Million to \$200 Million
Buddy Holly Hall of Performing Arts and Sciences, Lubbock, Texas

THE SPIRIT OF BUDDY HOLLY is alive and well in the form of a steel-framed performing arts center in the famed rocker's hometown.

Completed last year, the Buddy Holly Hall of Performing Arts and Sciences in Lubbock, Texas, has fulfilled the aim of creating a hub for the arts and culture community as well as a venue capable of attracting world-class performances. In addition, the new \$158 million venue plays home to Ballet Lubbock, the Lubbock Symphony Orchestra, and the Lubbock Independent School District Visual and Performing Arts. At a total of 218,000 sq. ft, it houses the 2,297-seat Helen DeVitt Jones Theater, the 415-seat Crickets Theater (named for Buddy Holly's band), a 5,600-sq.-ft multipurpose room, a 20,000-sq.-ft ballet school, a 3,300-sq.-ft restaurant, 21,400 sq. ft of back-of-house space, 36,100 sq. ft of lobby space, and a 6,000-sq.-ft covered outdoor event/performance space.

The complex was initially conceived as a predominately reinforced concrete building, with structural steel framing limited to the roof over the theaters and main lobby, the monumental stair, and a few other select elements. But on the advice of the construction manager, the team developed an alternative scheme that expanded the use of structural steel to include all the above-grade framing, including the theater balconies, the main theater stage, and the lobby was developed. In this scheme, reinforced concrete was limited to the foundations and the ground floor, as well as the two elevator cores, the exterior portion of the roof/canopy that formed the bird's tail, and the tilt-up walls on the studio theater.

The team completed an evaluation of both schemes using the criteria of cost, schedule, the size of the relevant skilled labor pool, the availability of tradespeople in the local marketplace, and the



Casey Dunn

Casey Dunn



ability for the quality expectations established with the Owner to be met. The structural steel scheme was determined to have an advantage in every category and was given the green light as the project proceeded into the design development phase.

The main performance space, the Helen DeVitt Jones Theater, presented multiple structural challenges and opportunities. The audience chamber, with a large main level and three horseshoe-shaped balconies, was designed to enhance audience proximity to the performers on stage, creating a “not a bad seat in the house” scenario. Theater balconies of this type are typically constructed out of reinforced concrete, so using structural steel framing instead required some creative thinking. The geometry of each balcony was highly complex, requiring careful thought on the framing layouts, member selection, and connection details to achieve practical, cost-effective, and buildable solutions.

A series of balcony rakers cantilever up to 32 ft from columns placed just behind the theater back wall. Vibration from rhythmic activities on the balconies was a major consideration given the large cantilever length of the rakers. The design uses 40-in.-deep rakers cranked in several locations to follow the profile of

the balcony. The design team used the curved horseshoe shape as an advantage, with a tension ring member placed near the front of the balcony to meet the vibration limits. To maintain a thin edge profile and sightline clearances below, a shallower 14-in.-deep section was spliced onto the end to create the front two rows of the balcony. The horseshoe nature of the balconies required each of the structural steel members for the risers to be bent to follow the curvature of the space.

On the lower balconies, standard wide-flange beam sections are used for the risers, which span between the rakers, support concrete on deck for the treads, and serve as formwork for the concrete risers. However, on the uppermost balcony, the height of the risers meant that the use of standard steel sections was not practical or cost-efficient. To address this situation, the team created a steel “Z” profile that was not only curved but also varied in height to follow the profile of the seating. This profile was created by bending an angle for the top and an angle for the bottom flanges, followed by welding on a variable height steel plate for the web. Web openings were then incorporated to allow for air distribution below each of the seats.



Entuitive

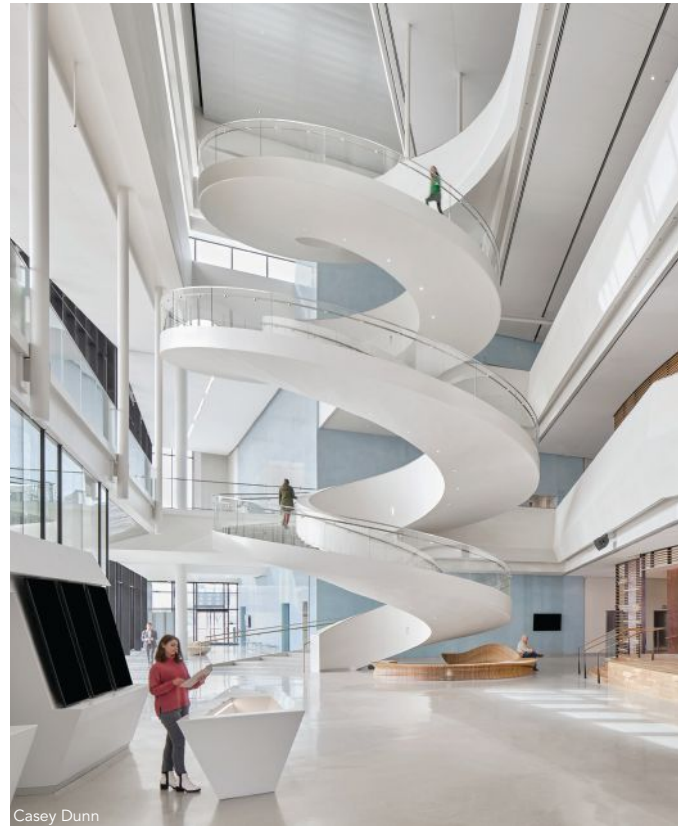

Casey Dunn

Above the audience chamber, a series of structural steel trusses frame the roof. Deck on purlins is supported by the sloping truss top chord to follow the roof profile. The elevation of the bottom chord of the trusses was tailored to achieve the optimum audience chamber volume from an acoustics perspective. Concrete on metal deck with sufficient mass for acoustics was then provided to create the ceiling, with the deck dropped down between the audience chamber ceiling beams and the bottom chord of the trusses. Openings are provided in this ceiling cap to allow for retractable acoustic banners to allow for further tuning of the audience chamber.

Steel also helped achieve structural success in the three-story Christine DeVitt Main Lobby. A dramatic shift inward of the main exterior wall at the upper levels of the lobby was driven by aesthetic and acoustics considerations. To keep the lobby space column-free, a roof truss spanning more than 150 ft was introduced along this line. The 45-ton truss varies in depth from 12 ft at supports to 14 ft at midspan, which was achieved through a sloping top chord, and was erected using two cranes. This truss supports many different elements, including the lobby roof, exterior cladding, the lower sloping roof overhang, and the main entrance canopy. The exterior of the building was inspired by the colors and shapes of the landscape of West Texas, including the prismatic and layered rock formations of nearby canyons, and features a combination of solid panels and linear windows suspended from this truss.

The bottom of this cladding is terminated by a sloping roof that pushes out from the exterior line above and is supported by a line of columns along the curtain wall below. The roof then continues by cantilevering past the columns to provide a sunshade to the curtain wall from the Texas sun. The back span of the sloping roof is supported from the truss. Round, slender, architecturally exposed structural steel (AESS) hangers emerge from below the sloping roof and extend down to support one end of custom tapered plate girders at level 2. These custom tapered plate girders support the

VIP lounge area on level 2 and then cantilever out 25 ft to create the main entrance canopy, which is a modern take on the marquee.

The visual highlight of the lobby, the monumental stair, conveys a grand architectural and structural statement thanks to hollow structural sections (HSS) and steel plates. The stair soars 56 ft across three stories and uses 145 tons of steel. The aesthetics of a thin outer edge and glass guard is contrasted with the solid white plastered central spine, with the latter supporting cantilevering stair treads that vary in length between 8 ft and 14 ft. To form the helical shape of the stair, the HSS chords for the central spine and outer stringer were bent in two directions through induction bending. The HSS riser, steel plate tread, and outer HSS stringer were then connected to the central spine before finally welding the central spine web plate onto the HSS chords. The long spans, slender profile, low mass, and low damping ratio resulted in a low-frequency system that was particularly vulnerable to vibrations from human activity. Through finite element modeling and analysis, the team found that supplementary damping was required to meet the vibration limits, so a tuned mass damper (TMD) was added on the second and third flights of the stair.

Another significant element in the lobby, a series of glass fiber-reinforced concrete fins, also benefited from HSS. The fins not only add a dynamic aesthetic element but also contribute to shading the large expanse of curtain wall. The challenge was how to support these undulating fins, which are situated 5 ft off the curtain wall while giving them the appearance of floating. The solution was to fit a slender structural steel element within the profile of the fin, one that brought enough strength to support the fin weight and sufficient stiffness to prevent wind-induced fluttering. The team considered several HSS sizes and profiles, such as circular and rectangular, that were strong and stiff enough but could not fit within the sleek architectural profile of the fins—but oval HSS could. These elements were hung from the sloping roof overhang above, and the



Lee Lewis

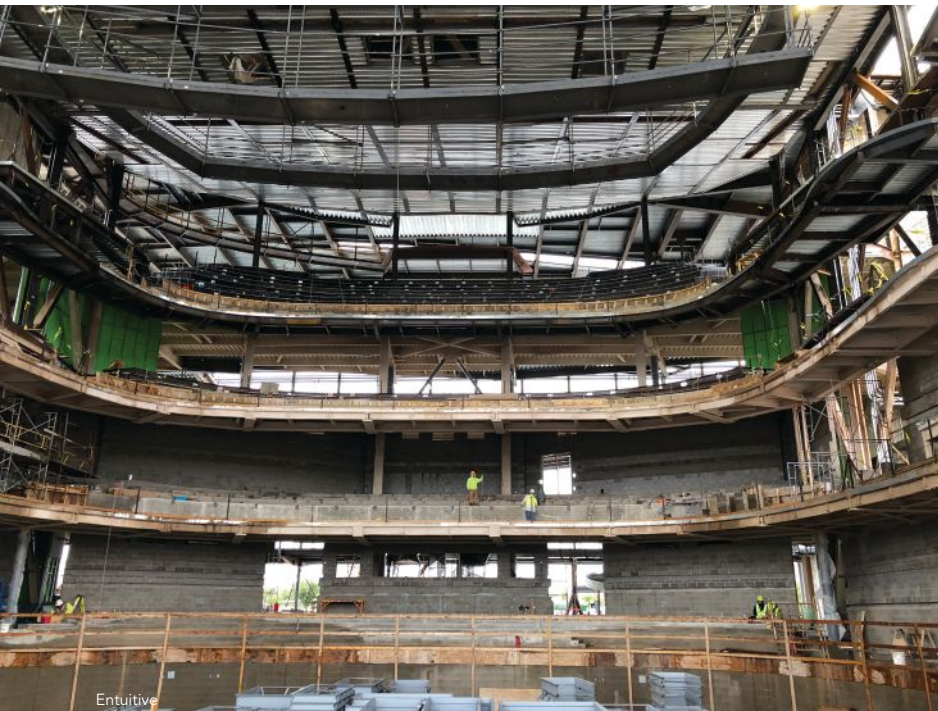

Entuitive

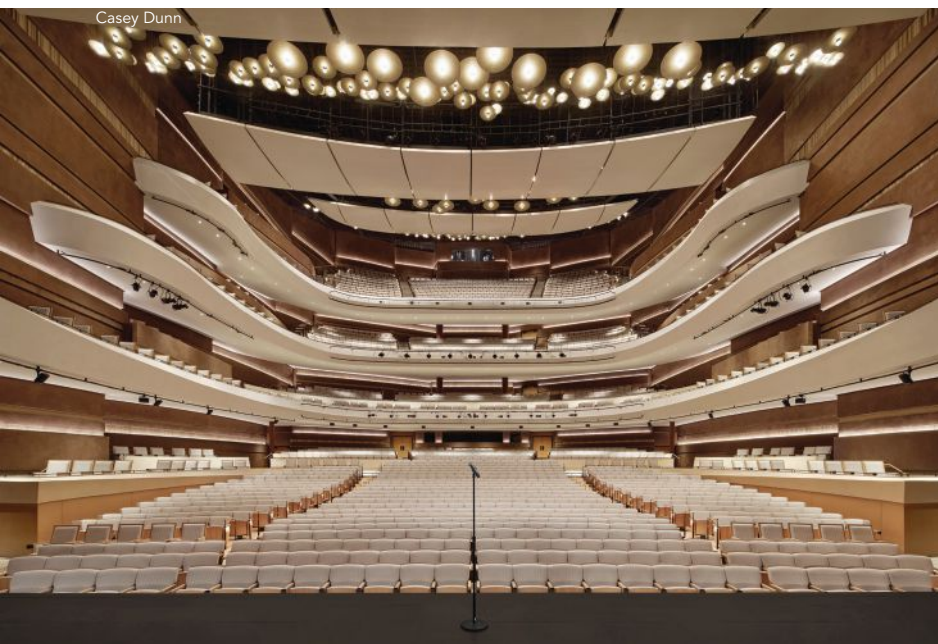

Casey Dunn

profile for each one was varied over its height by splicing three sections together; oval HSS11×6 was used inside the fin, and oval HSS8×4 was used above and below the fin.

Given the complexity of the project—which involved three architectural firms and three structural engineering firms, all responsible for different areas of the complex—the larger structural engineering team made the conscious decision to share and work in one Autodesk Revit model for the project and produce one consolidated set of construction documents. Using Autodesk BIM 360 and a live chat feature made this level of collaboration and coordination between different offices possible—e.g., two of the engineering firms coordinated in real time on the superstructure and substructure as each responded to the design progression and coordination from the broader team.

One other example of the project team’s collaboration in action is in the theater, where the related engineer used a parametric Grasshopper model developed by the design architect to generate the custom balcony risers inside the Revit as 3D parametric objects, as this was the only efficient way to convey the extremely complex geometry. The architects then used the live model for their background, with the engineer controlling future adjustments in the Revit model to precisely coordinate the steel framing with the refinements to the architectural profiles—much like a musical ensemble performing in the space would work in perfect harmony.

Owner

Lubbock Entertainment and Performing Arts Association

Developer/Other Consultant

Garfield Public/Private LLC

General Contractor

Lee Lewis Construction, Inc.

Architect

Diamond Schmitt

Architect/Structural Engineers

MWM Architects

Parkhill



Structural Engineer

Entuitive

Steel Team

Fabricators

Basden Steel Corporation, Inc.  

TrueNorth Steel  

Erector

Deem Structural Services, LLC 

Detailer

Foy Consulting & Engineering, LLC 

Bender/Roller

Albina Co., Inc. 



MERIT AWARD \$75 Million to \$200 Million International Spy Museum, Washington

THE INTERNATIONAL SPY MUSEUM needed a new place to hide in plain sight.

Having outgrown its original home in Washington, D.C.'s Penn Quarter, the organization was in pursuit of a new iconic location that would allow it to effectively continue its mission of educating the public and showcasing the history of espionage. The Museum identified 700 L'Enfant Plaza, a few blocks south of the National Mall, as the ideal location to meet its needs. The new steel-framed, 141,000-sq.-ft., eight-story, \$162 million project includes three floors of museum exhibits resting on a base of retail, education, and lobby spaces. The facility is topped with offices, additional educational space, and a dramatic events facility with a green rooftop and sweeping views of the city.

The overarching goal was to create a world-class museum with Smithsonian-level thermal and humidity controls in an architecturally impactful building. The Museum partnered with JBG Smith, then hired Rogers Stirk Harbour + Partners and Hickok Cole to make their vision a reality. Creativity and collaboration were critical to the success of this project, which was to be built above an existing operational subterranean shopping mall and garage that support a major Washington Metro station and surrounding office buildings. The team was also faced with a strict budget and a 48-month design and construction schedule.

Washington is generally known as a "concrete town," where cast-in-place concrete structures are prevalent. However, as design

discussions began during the early phases of the museum project, it became clear that structural steel was the best choice for the building structure, as steel provided the greatest flexibility needed to achieve the desired design aesthetic as well as provided engineering, constructability, and cost benefits.

The building's concept is a play on the business of espionage: being hidden in plain sight. One of its main architectural features is a five-story glass atrium, dubbed the Veil, that is suspended in front of an enclosed exhibit box and feature staircase. This unique structure provides a stage for the movement of people throughout the exhibit levels, contributing to the pedestrian experience along 10th Street. With its evocative form, powerful exposed structural steel sloped columns, and pleated glass veil, the Museum serves as a catalyst to revitalize L'Enfant Plaza.

Within the Veil lives an intricate series of monumental stairs and platforms constructed from architecturally exposed structural steel (AESS) members of varying shapes and profiles, all of which had expressed connections to the built-up AESS building columns. Structural steel provided the strength and stiffness needed to achieve the architectural vision for this space by keeping the structural members as small and attractive as possible. Another dramatic example of the museum's elegant design is the series of "L-shaped" red-painted columns, constructed from grade 50 steel plates, along the south and west faces that slope at an angle of approximately 2.5:1 vertical to horizontal and serve as part of the building's

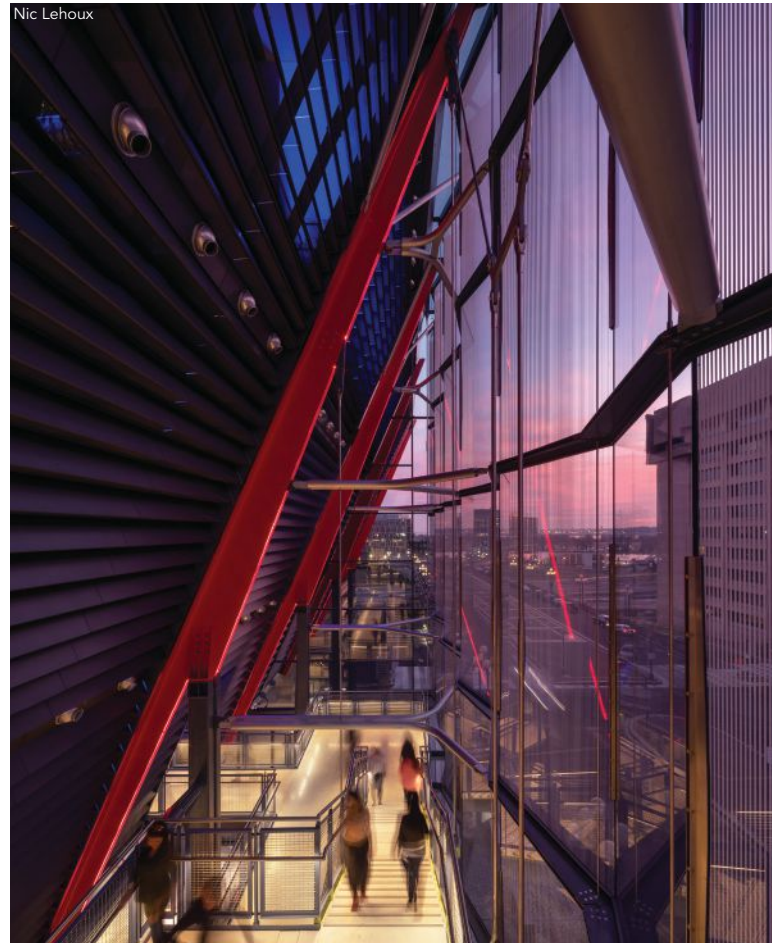
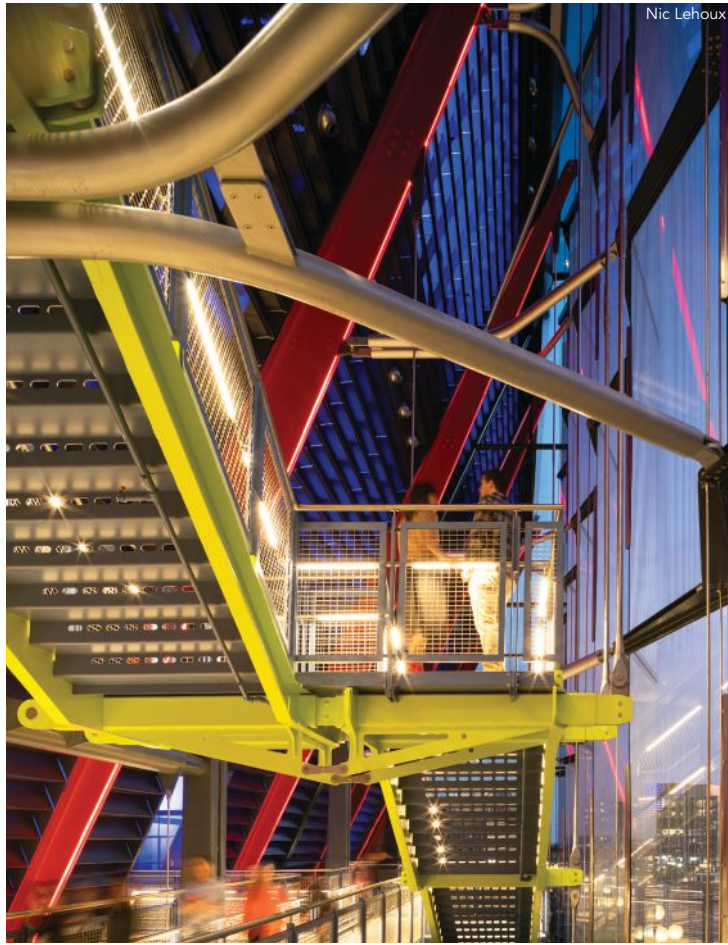

gravity load-carrying system. The columns taper and have reduced depths at the top where structural demand diminishes to reduce material cost and for aesthetics.

The museum superstructure is constructed above an existing four-story concrete structure built in the 1960s, and the addition of a new building above was not anticipated in that original design. In order to support the new museum superstructure loads, strengthening of the existing concrete structure was necessary. It therefore became very important to keep the museum's structural weight as minimal as possible in order to make this existing strengthening cost-effective—another reason to employ a structural steel frame. The typical museum floor system consisting of long-span steel beams and girders with lightweight concrete on composite metal deck provided the open spaces required for the museum programming while minimizing the self-weight of the structure. In addition to factoring in the existing building space below the museum, the project also had to factor in the proximity of the surrounding buildings and streets. As the site is not much larger than the building footprint, the project required closely coordinated deliveries and tight sequencing.

Steel brought several advantages from a constructability perspective as well. The construction schedule for the project was aggressive from the start, and steel allowed the building superstructure to be completed in a faster timeframe than would have been possible with cast-in-place concrete options. In addition, by implementing a design incorporating structural steel with unshored composite metal deck construction, the need for expensive and intricate concrete formwork was eliminated from the project.

The entire team understood from the outset of the project that challenges would arise due to the complex design. Months

of preplanning, 3D modeling, mockups, and field tests were performed to ensure that what was shown in the model could actually be built in the real world. One complication became evident during non-destructive testing of splices between the building structure and the sloping column cantilevers. The cantilever sections were W30×124 sections with ¾-in. web doubler plates on each side of the web. These cantilevers were then spliced to main building beams made with the same built-up section with a complete-joint-penetration (CJP) splice. When ultrasonic (UT) testing was performed, the interface between the doublers and the webs of the W30 beams created false-negative results, but the engineer and testing agency responded by developing a testing procedure that would satisfy the design requirements.

From a design standpoint, the museum makes its mark by featuring AESS as a prominent portion of the architecture and structure and wasn't just employed as a highlight or an accent. Unlike most projects in our hard work and structural craftsmanship is often hidden or covered by fireproofing/finish trades, the structural steel is the premier architectural feature seen by museum patrons, visiting tourists, or even those passing by on nearby I-395. As such, a high level of coordination was required at the sloping front of the building, where the curtain wall and monumental stair are both connected back to the sloping steel columns. Due to the design of the sloping columns, connection points for the curtain wall and stair had to be incorporated into the shop fabrication of these columns. This meant that connection points had to be coordinated with each supplier's internal tolerances and also allow for the project-specific steel erection tolerances. Both the stair hangers and curtain wall connections were attached back to the columns by a 2-in. pin, so there was no room for error once the structural steel was fabricated and erected.

Another façade system that had to be factored in was the metal panel rain screen system. To support this system, vertical W6 girts were placed around the entire building perimeter 5 ft on center. Due to the project schedule, these metal panels could not wait for field dimensions to be taken between sloping columns prior to production, so the location of the steel columns had to fall within the prescribed AESS tolerances. The majority of this coordination took place by way of model sharing between individual subcontractors and a weekly, sometimes daily, building information modeling (BIM) process in which the team established allowable tolerances and individual system requirements.

The various AESS elements also involved different finish requirements, some of which necessitated different fabrication and erection details in order to accommodate the different coating types and thicknesses. These included AESS that would remain uncoated for fireproofing, interior AESS prime painted for finish coats, interior AESS prepped for intumescent coatings, exterior AESS hot-dip galvanized and prepped for finish coats, and exterior AESS hot-dip galvanized prepped for intumescent coatings. To make sure the finish of each piece of steel was correct, the steel team traded color-coded models with the design team to visually check and ensure each piece came to the field with the correct finish. (For more on the various AESS levels and their individual requirements, see “Maximum Exposure” in the November 2017 issue in the Archives section at www.modernsteel.com.)

Of course, like the activities of a spy, time was of the essence with this project. Steel fabricator SteelFab’s involvement began approximately one year before it was awarded the contract for the structural steel package. During this time, conceptual and schematic design-level feedback was provided to general contractor Clark Construction and the rest of the design team about some of the feature elements on the building. The willingness of the project team to engage a steel fabricator well ahead of the procurement stage helped steer certain design decisions in directions that maintained the architectural intent but allowed for more fabrication- and erection-friendly details.

Had this project been procured under a typical design-bid arrangement, it wouldn’t be an exaggeration to say that three to four months would have been added to the structural steel schedule alone. A significant portion of the upfront work on the project involved delving into the details of earlier discussions about coatings, connections, tolerances, and AESS expectations in general. Only with the full buy-in of all project team members was this kind of progress achieved in such a short amount of time.

For more information on the International Spy Museum, see “I Spy” in the June 2021 issue in the Archives section at www.modernsteel.com.



Dan Cocciardi

Owner’s Representative

JBG SMITH

General Contractor

Clark Construction Group, LLC

Design Architect

Rogers Stirk Harbour + Partners

Architect of Record

Hickok Cole

Structural Engineer

SK&A Structural Engineers, PLLC

Steel Team

Fabricator

SteelFab, Inc. 

Erector

Memco LLC 

Detailer

Prodraft, Inc.

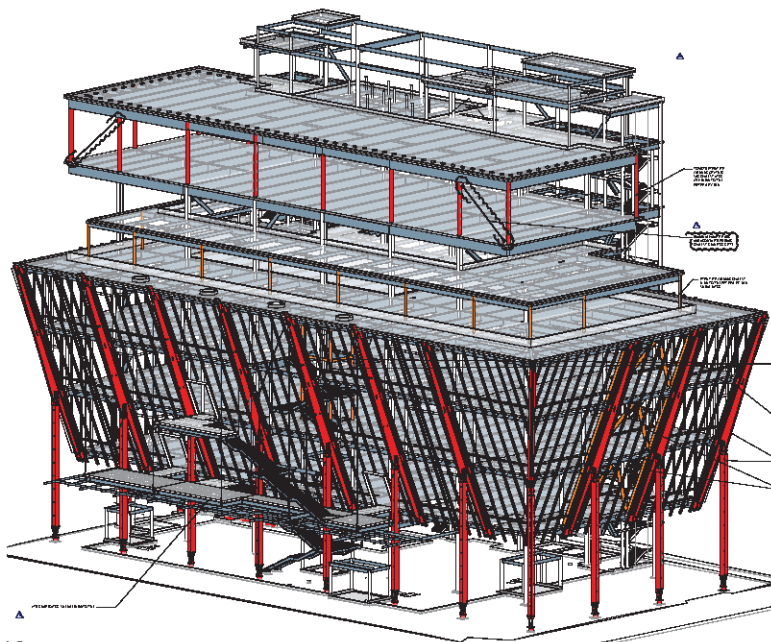



MERIT AWARD \$15 Million to \$75 Million

United States Olympic and Paralympic Museum, Colorado Springs, Colo.

THE NEW UNITED STATES Olympic and Paralympic Museum in Colorado Springs is intended to be a celebration of the Olympic and Paralympic Games as well as the participants themselves—so much so that the building is wrapped in an aluminum facade that mimics the appearance of an athlete's costume.

This façade is stretched over a steel superstructure composed of 9,000 diamond-shaped panels that produce gradients of color and shade, giving the building another sense of motion and dynamism.

The museum also acts as an anchor for the new City for Champions District, forming a new axis and bridging downtown Colorado Springs to America the Beautiful Park. The design of the 60,000-sq.-ft building was founded on the idea of a continuous

path from the top to the bottom to allow for accessibility, a key element of the project, to create a museum in which all visitors could enjoy the same experience.

The steel-framed building is composed of four volumes, arranged in a pinwheel formation that contains galleries, an auditorium, and events space surrounding a central atrium. Because steel is a material that can be easily manipulated, cut, and rewelded into many different shapes and forms, it could most easily accommodate the versatile shapes needed for the spiraling nature of the floors and overall complex geometry. It was also capable of supporting the long trusses, cantilevers, and sloping columns and floors most efficiently and also provided the fastest speed of construction.



Scofidio + Renfro

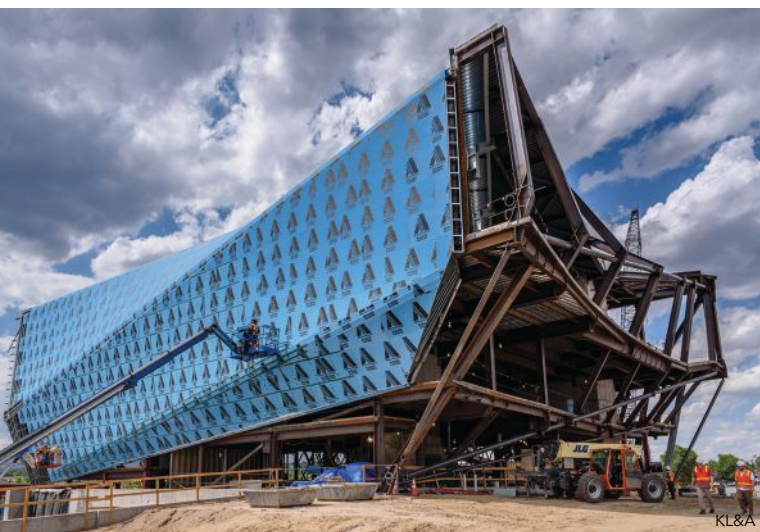

KL&A



Ashley Murphy

The structural system offers an open, inviting façade to the public while evoking movement. It involved a variety of load path solutions that needed to be achieved to ensure the dynamic nature of the building, including a 140-ft-long-truss, tilted columns, and cantilevered floor members. Due to the building's unorthodox shape, the steel framing and the aluminum façade both lean away from the center, which made steel erection more challenging than what would be associated with a more typical grid. The construction team countered this situation by placing temporary shoring points and implementing an extensive erection sequence before other tiebacks within the building could be made. In addition, the leaning nature of the building's exterior required the lateral system to resist not only traditional wind and seismic loading but also loading from the gravity system.

Speaking of the façade system, each of the 9,000 metal panels has its unique conditions, including the connection of the exterior walls to the floor and roof elements. A special clip was fabricated by the metal stud provider that allowed for the skin's exterior framing to be adjustable for each individual condition. The panels are

all folded in half, with a visible crease that creates two triangles, a design decision that led to a large amount of model testing and digital studies to discover the panels' reaction to light. The possibility emerged for these "scales" to animate the surface as the light changes in Colorado Springs throughout the day.

Early involvement of the steel detailer, fabricator, and erector was extremely beneficial to the project, with all parties being at the table for most of the design meetings starting as early as schematic design and through to the construction documents phase. This approach helped the team coordinate how the loads needed to be placed to efficiently create the building. In fact, structural engineer KL&A also performed the steel detailing, which further enhanced the collaborative process. The relationship helped resolve an issue during construction where one of the concrete cores was misaligned near the top by roughly 5 in. The integrated approach between structural engineer/steel detailer and steel fabricator helped resolve the issue by quickly revising several connections, a scenario that mimics the individual contributions to teamwork that the museum celebrates.

KL&A



Ashley Murphy

Owner

United States Olympic & Paralympic Museum

General Contractor

GE Johnson

Architects

Anderson Mason Dale Architects
Diller Scofidio + Renfro

Structural Engineer

KL&A Engineers and Builders

Steel Team

Fabricator

Drake-Williams Steel 

Erector

LPR Construction 

QUICKFRAMES™

The Leader in Engineered Structural Roof Frames

Is *waiting on*
Mechanical Locations
Costing You
Time & Money?



Try QuickFrames
instead.

Get Pricing & Fast Quotes
www.QuickFrames.com
(480) 656-1575
NEXT DAY SHIPPING AVAILABLE!



ST. LOUIS

SCREW AND BOLT

Connecting amazing structures Nationwide!



Call or email us your inquiry!
St. Louis Screw & Bolt
sales@stlouisscrewbolt.com
800-237-7059

PROUDLY MADE IN THE USA



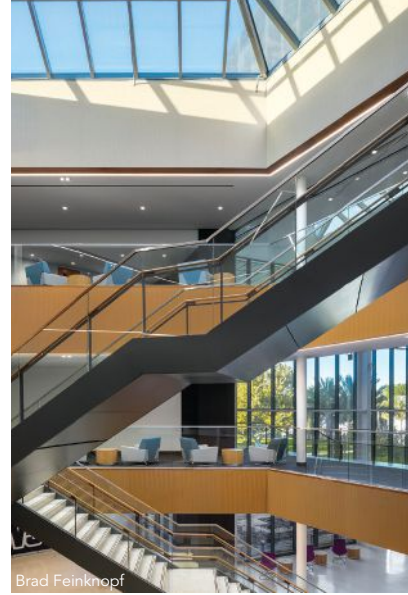

MERIT AWARD \$15 Million to \$75 Million
L. Gale Lemerand Student Center, Daytona Beach, Fla.

COLLEGES AND UNIVERSITIES often design buildings as “gateways” from a town to a campus or from one campus area to another. In the case of Daytona State College’s new steel-framed student center, this approach was more than just figurative.

The Board of Trustees envisioned the new building as a gateway that would transform the college’s appearance to the community of Daytona Beach and better represent its mission of advancing the economic development of the city and Volusia County.

The existing campus essentially “turned its back” on the community of Daytona with inward-looking and internally accessed buildings surrounded by parking lots between public roads and the campus. The effect was that of a shopping mall. The new 75,000-sq.-ft steel-framed student center on the edge of campus reverses this perception with a massive bronze-clad gateway portal between the community and the campus, emphasizing transparency and openness.

Like coral stone outcropping rising from the Floridian shoreline, an organically curving coral stone and bronze wall faces the world-famous Daytona International Speedway Boulevard and embraces visitors like two outreached arms forming a landscaped welcome lawn at the campus entry. Rising from the center of the gently curving wall is the portal, framing the opening to the student center and giving passage to the main quadrangle and campus beyond. Additionally, to allow open access to the center of campus, a portion of the curving stone wall cantilevers above grade to allow students and staff to pass unimpeded from parking to the campus quad.

The design team selected structural steel because it possessed the best performance characteristics to achieve the project goal of openness. Most prominently, it allowed the team to economically and efficiently create the 90-ft-tall portal in the center of the building that both separates and joins each wing (side) while also effectively resisting hurricane-force winds. The light structural steel framing for the

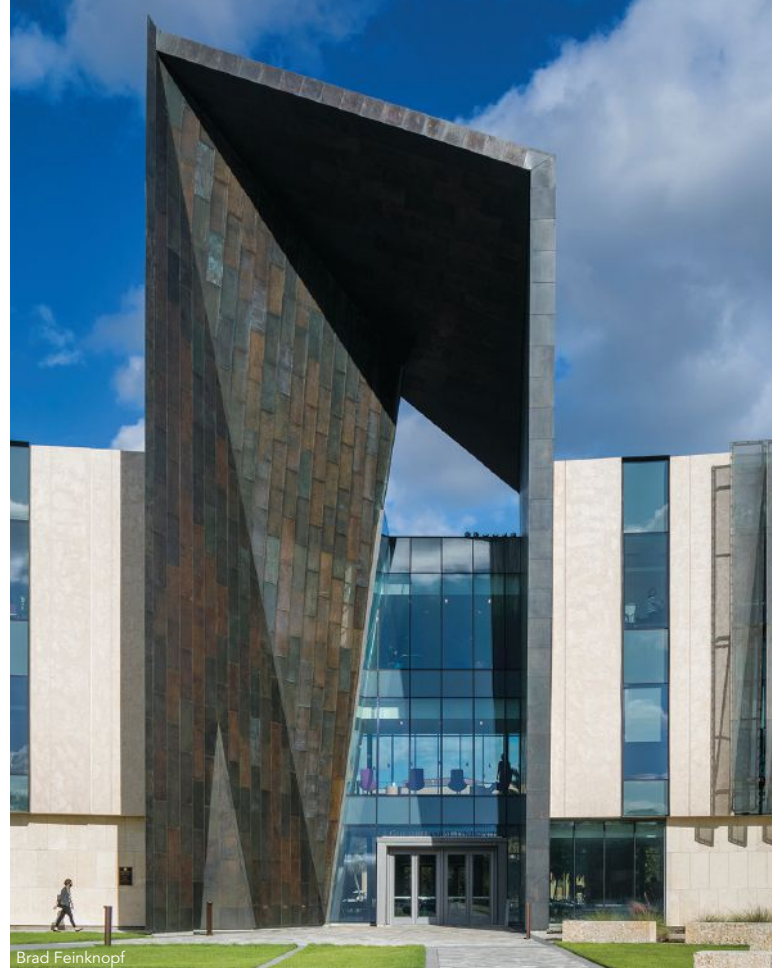
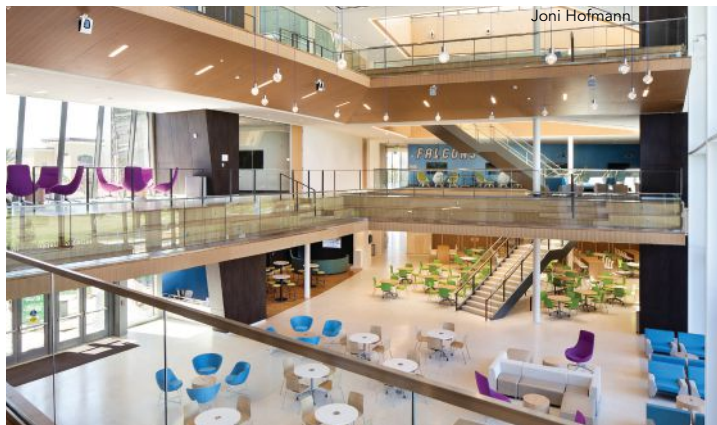
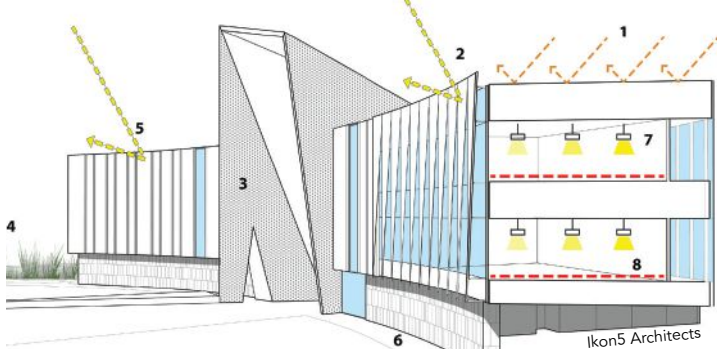

portal also provided the perfect substrate to anchor the bronze rain screen and easily achieve the screen's angular form. Beyond the gateway, steel frames the rest of the building as well and also facilitates a large opening in the center of the floor plate that creates a three-story student commons with cantilevered amphitheater seating—while *also* transferring lateral loads through the building.

The most significant structural challenge for the project was cantilevering two stories of the student center over the pedestrian pathway connecting the campus parking lot with the center campus quadrangle. The new building's footprint impeded this preexisting pedestrian connection and in order to maintain it, the team lifted the building above grade and cantilevered a portion of the second and third floors over the pathway. The challenging part was creating a rigid frame that would not want to overturn while transferring lateral forces. The solution was to create a Vierendeel truss at the southeast corner of the building, before the cantilevered portion of the floor, and attach the side of the truss to a freestanding stair tower. The structural frame of the stair tower acts as a mast supporting the truss, which in turn supports the second and third floors and allows pedestrians to move freely beneath.

The building's steel framing also assists with the sustainable design strategies of a high-performance building. The large, glazed facades

on the south and west express welcome and openness but also presented a significant design challenge for combatting solar heat gain in the steamy Florida environment. The team addressed this situation by designing bronze solar screens to naturally ventilate the façade and reduce heat gain on the building and load on the cooling systems, with the screens being attached to the steel framing.

- Owner**
Daytona State College
- General Contractor**
Perry-McCall Construction, Inc.
- Architect**
ikon.5 architects
- Structural Engineer**
BBM Structural Engineers, Inc.
- Steel Team**
- Fabricator and Detailer**
GMF Industries, Inc. 
- Erector**
GMF Steel Group 

MERIT AWARD Less than 15 Million
**2Life Communities
Administrative Offices,
Brighton, Mass.**

BRINGING PEOPLE TOGETHER is 2Life Communities' business.

And the affordable senior living community developer's CEO wanted to do the same for its employees and initiated an effort to relocate the administrative staff of 55, which was previously spread across its Brighton campus, all under one roof in a collaborative, inclusive, and equitable office culture.

The company decided to build two floors on top of one of its existing facilities, which acts as a link building between two residential towers. The existing building includes a fitness center, a library, an auditorium, and other rooms that support resident programming. And the addition would need to be constructed with no disruptions to the resident floors below.

Because of the way the existing building was designed, it was not possible to support an additional two stories by introducing new columns through the building. The building would need to be supported from the outside, and the solution came in the form of two 90-ft-long steel trusses held up by four exterior steel columns.

In addition, the new structure needed to be integrated architecturally with the existing building. The budget did not allow for the wholesale redesign of the existing building or complicated screens, so the design team needed to get creative. The final design of the addition incorporates the vertical rhythm of the existing building through a perforated corrugated metal screen on the south face of the building that integrates both elements into a cohesive whole, as well as limits direct sunlight and improves overall comfort to occupants in the summer months.

With limited options for placing the large pile-supported footings, the team decided to cantilever the front of the building, which houses conference and meeting rooms that span the building's width. And rather than hiding the trusses, the team decided to celebrate and integrate them into the overall design of the space. As such, the trusses were left exposed and painted a bold yellow.

Owner's Representative

2Life Communities

General Contractor

Dellbrook | JKS

Architect

DiMella Shaffer Associates

Structural Engineer

Odeh Engineers

Fabricator/Detailer/Erector

Soucy Industries, Inc. 

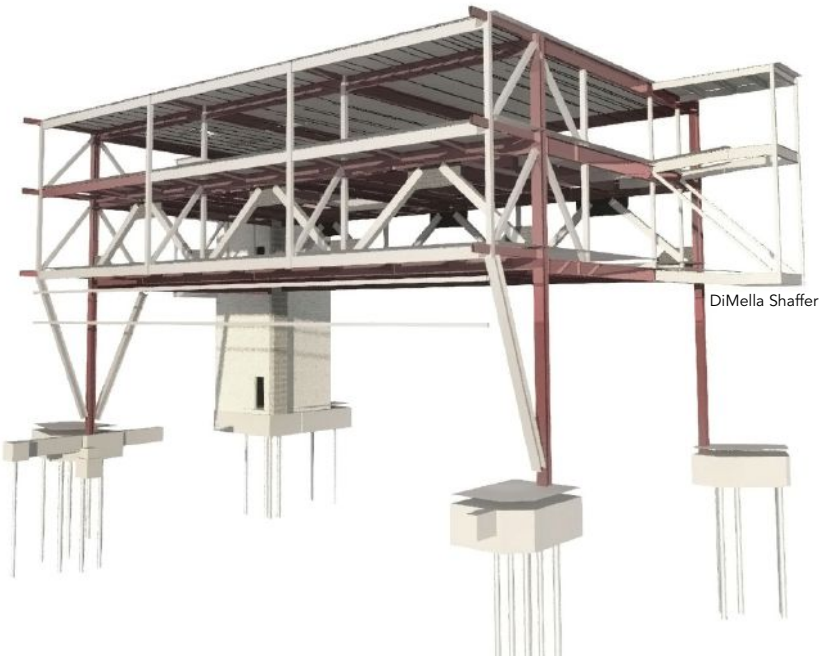



Robert Benson



Robert Benson



Robert Benson



Robert Benson

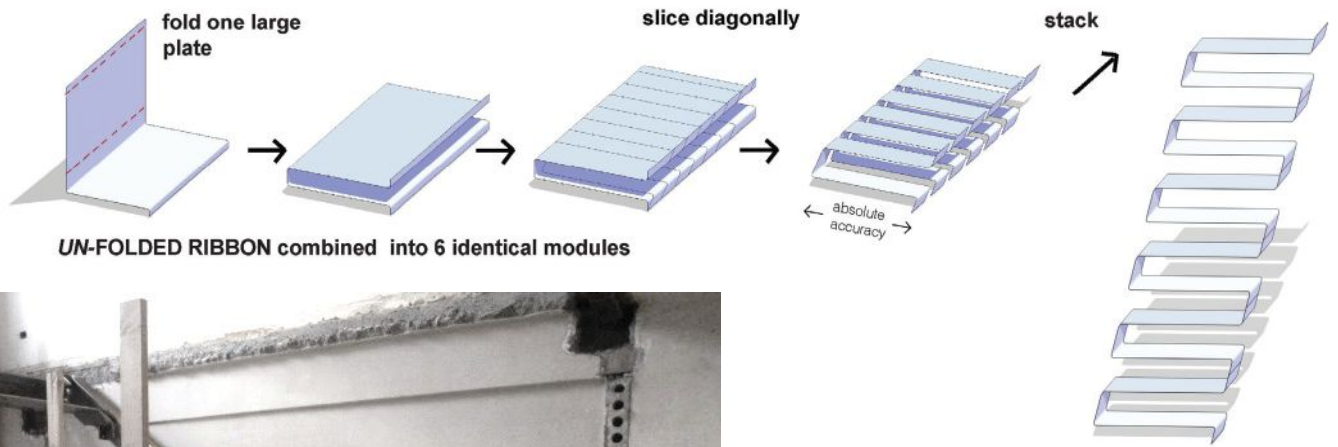
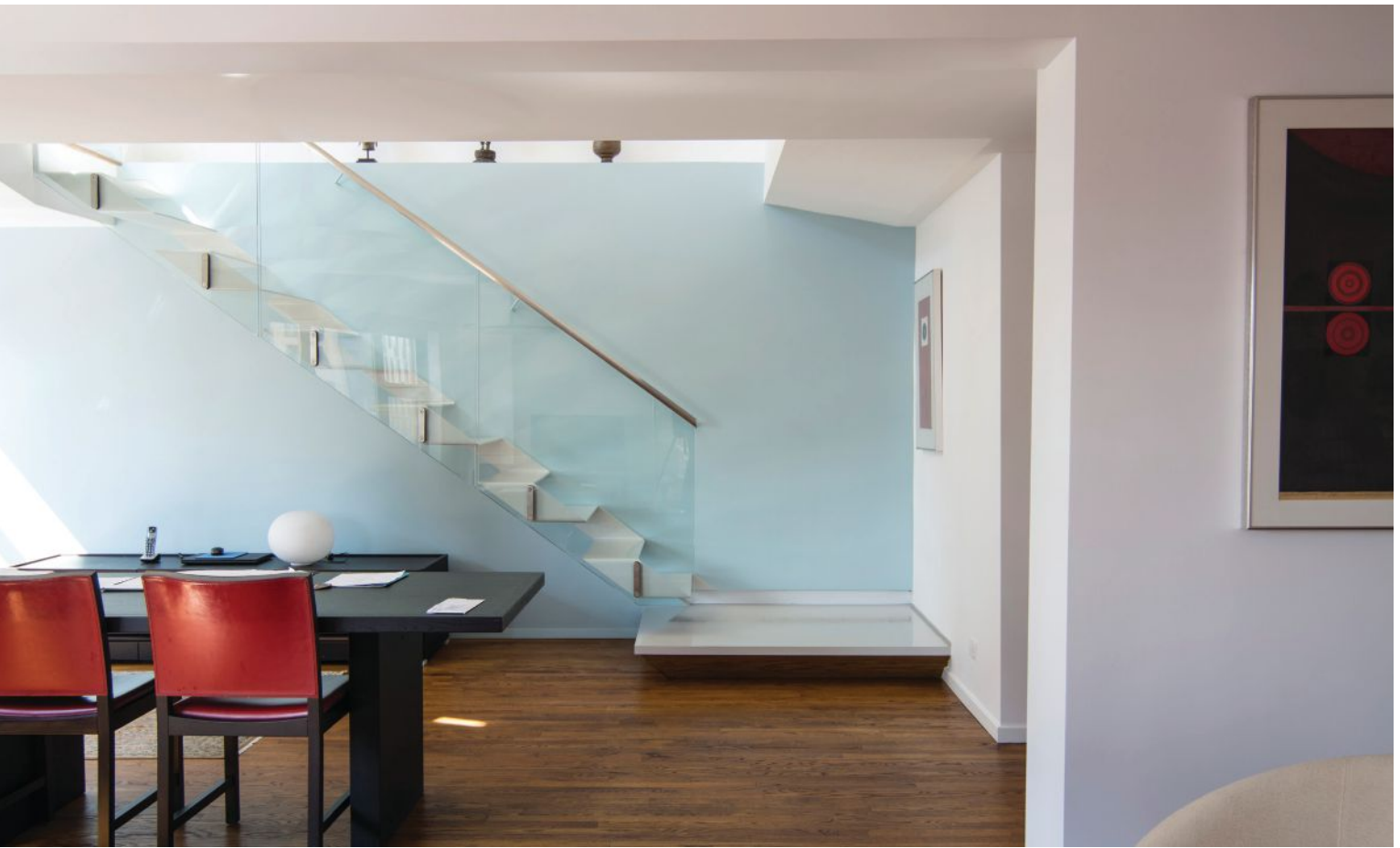

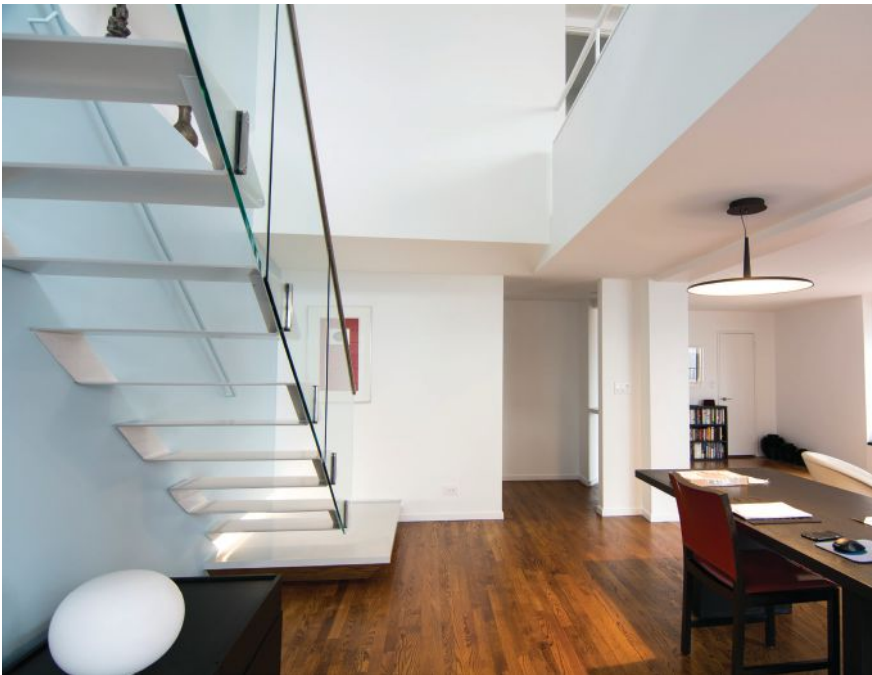
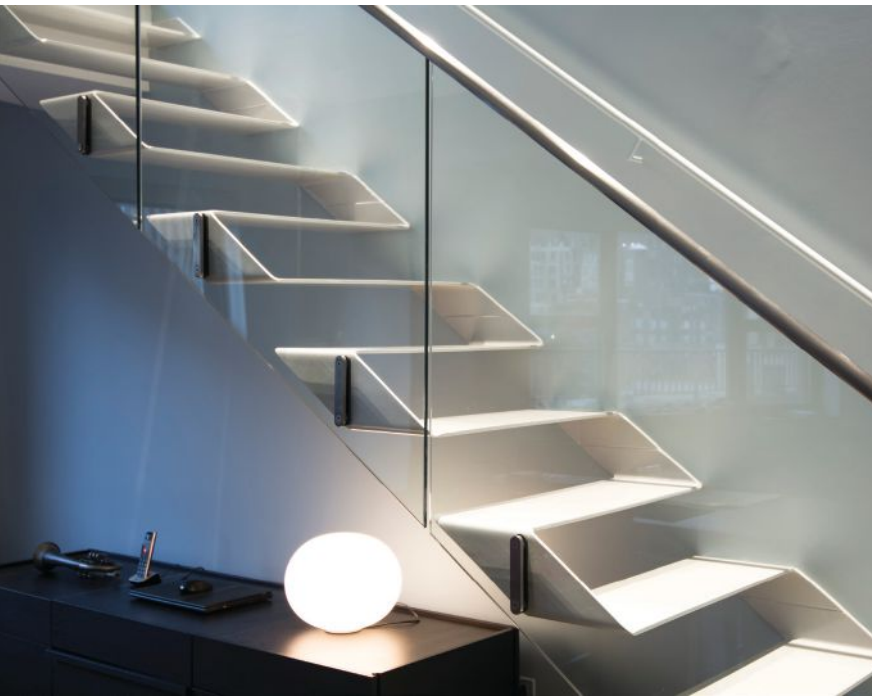

MERIT AWARD Sculptures/Art Installations/
Non-building Structures
**Ascension of the Celestial Maiden,
New York**

A NEW STEEL STAIRCASE in a Manhattan apartment facilitates movement between floors and adds an artistic centerpiece to a refreshingly renovated space.

The project combines two apartments in a 1960s-era building vertically by opening the floor in the upper unit and inserting a new staircase. The two-story high volume and the staircase were designed to become the focal point of the enlarged apartment while capitalizing on the spectacular views of the East River and the United Nations Headquarters.

Structural steel was used for its slim profile and visual lightness, as well as its ability to create a fluid shape. The staircase was conceptually inspired by paper folding art principles where a single strip forms the flight of risers, and it provides a stark visual contrast to the adjacent demising wall. The continuous ribbon of steel is much more delicate than the typical cantilevered staircase and creates an ephemeral feeling, like the fabric streamers of gymnasts, a ribbon floating in the air, and the transparency through the steps maintains the views and opens up the space. There was very little documentation of the existing structural conditions, and using cranes and large structural elements would have been cost-prohibitive.

To form the staircase, a large standard sheet of $\frac{3}{8}$ -in.-thick steel was folded just four times, sliced “diagonally” into six identical modules, then finally stacked. This procedure resulted in precisely identical modules that couldn’t have been achieved by bending the strips one by one. This accuracy was essential to accommodate the glass handrail, which required precise alignment. Every step has a 1-in. radius to emphasize the continuity of the bent steel plate—nothing to distinguish tread or riser.

While the precision of the project would appear to have been facilitated by high-tech equipment and processes like laser cutting, CNC machines, or waterjets, it was achieved using traditional bending methods and saws, which were deemed more affordable for such a small project. Regardless of the process, structural steel was the only way to achieve this design and its fluid format and visual openness.

Owner

Robert Ciricillo

General Contractor

Excel Builders & Renovators Inc.

Architect

Yoshihara McKee Architects

Structural Engineer

Yoshinori Nito Engineering and Design PC



**PRESIDENTIAL AWARD
FOR EXCELLENCE**
In Structural Design
Rainier Square, Seattle

RAINIER SQUARE adds a new and exciting mixed-use destination in downtown Seattle that revitalizes an entire block and its surrounding area—and it's also the first building to implement the SpeedCore system, which has effectively reinvented the rules of high-rise steel construction.

Soaring 850 ft above the city, the 58-story, 1.4 million-sq.-ft tower is comprised of an active retail podium, Class-A office space, and high-rise luxury apartments. It also includes a seven-story, below-grade parking garage that accommodates nearly 1,000 vehicles, and its podium base directly connects to adjacent Rainier Tower.

The building serves as a proof-of-concept for SpeedCore, a novel and innovative structural steel system using modular, prefabricated, concrete-filled, composite-plate steel shear wall (CF-CPSW) panels to create a high-rise tower's structural core quickly and cost-effectively. Originally designed to be built with a traditional, reinforced concrete core surrounded by structural steel, composite floor framing, the project benefitted from the forward-thinking mindset of developer Wright Runstad and Compan, who recognized the opportunity to save time and money by erecting the tower's structural core using SpeedCore.

Constructing Rainier Square required 55 ironworkers and 15,000 tons of steel—including more than 350,000 steel rods with more than 700,000 welds. During construction, the steel faceplates and tie rods of the hollow modules supported eight floors of decking before they were filled with concrete. After the concrete infill was poured and cured, the system worked compositely to create a hardy structural core, with each component doing its part:

- Steel plates provide reinforcement and primary resistance to tension and shear demands on the lateral system.
- Concrete infill provides resistance to larger overturning compressive loads under lateral demands.
- Steel tie rods provide confining pressure for the concrete, resulting in superior seismic performance.

At Rainier Square, SpeedCore's swift construction sequencing involved three high-level steps:

1. Steel prefabrication. More than 530 plates—each ½ in. thick, 30 ft to 40 ft wide, 14 ft tall, and weighing approximately 20 tons—were fabricated then preassembled in connected pairs 21 in. to 45 in. apart with 1-in.-diameter steel tie rods to form modules ready for site installation and concrete fill. The panels were fitted with openings for MEP services, penetrations for fire protection pipes, and connection materials for field-attached floor beams.
2. Module transportation placement. Once assembled, the modules were stacked onto trucks, transported to the construction site, hoisted into place, and field welded.
3. Filling the “sandwiches” with concrete. As the panels were erected, concrete was pumped into each module, resulting in a configuration much like an ice cream sandwich, with steel panel “cookies” on the outside and concrete “ice cream” filling inside.

In all, the SpeedCore approach lived up to its name, shortening the original 32-month construction schedule by ten months versus using a traditional core system. At the pace of four floors per week, erection occurred at a lightning-fast tempo compared to traditional cores (one floor every three to five days). In addition, implementing SpeedCore eliminated the challenges of expensive, time-consuming, and labor-intensive processes such as setting formwork, installing reinforcing steel, placing embedded plates, and the level-by-level concrete placement and curing associated with reinforced concrete cores found in most high-rise buildings.

Completing Rainier Square ahead of schedule allowed the owner to save money in construction-loan carrying costs and general construction operating costs. Opening sooner provided an earlier revenue stream for the owner to lease office floors, retail spaces, and apartment units. If you visit Rainier Square today, you can witness the project team's pride in SpeedCore. Sections of the structural core's CF-CPSW panels have been left uncovered and exposed in different parts





MKA

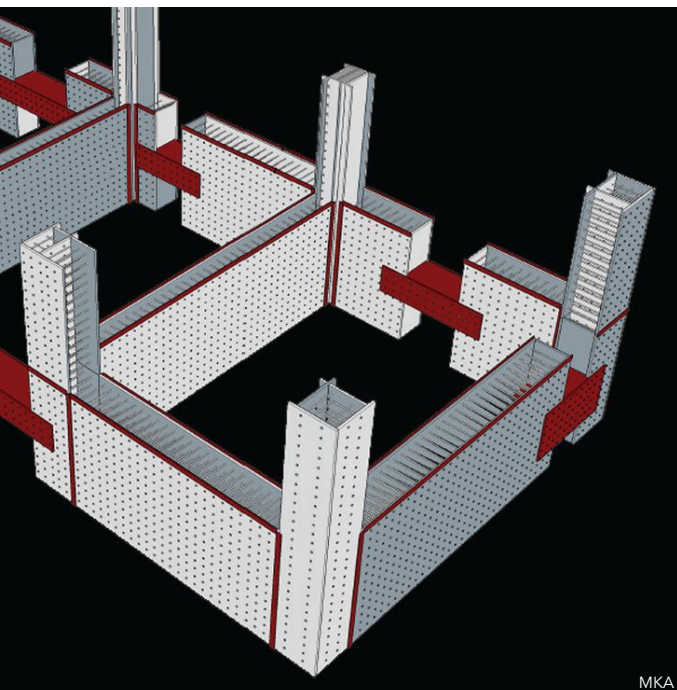

MKA



MKA

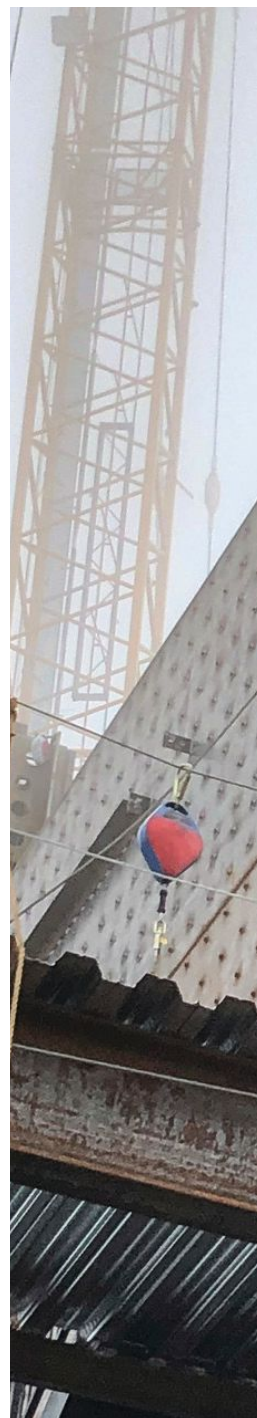

MKA



**RAINIER SQUARE
DECEMBER 2020**

MAKING HISTORY WITH THE WORLD'S
FIRST STEEL PLATE "SANDWICH" CORE.

EXPOSED IN FRONT OF YOU IS THE ACTUAL
TOWER CORE. WE WANTED TO SHARE THE
BEAUTY AND STRENGTH OF THIS BUILDING
CORE AS A TRIBUTE TO ALL OF THOSE
INVOLVED IN THIS NEW CONSTRUCTION
METHOD.

IT IS CONSTRUCTED FROM 7,000 TONS
OF STEEL AND FILLED WITH 18,000 CUBIC
YARDS OF CONCRETE. IT WAS ERECTED
IN 11 MONTHS BY 55 IRON WORKERS.
THE STEEL AND CONCRETE COMPOSITE
CORE CONSTRUCTION APPROACH SHAVED
9 MONTHS OFF THE CONSTRUCTION OF
A TRADITIONAL CONCRETE CORE.



Tim Rice

of the lobby, allowing visitors to touch the raw steel plates and tie-rod welds, and read a bronze plaque to learn about SpeedCore's innovative nature. ■

Owner

Wright Runstad & Company

General Contractor

Lease Crutcher Lewis

Architect

NBBJ

Structural Engineer

Magnusson Klemencic Associates

.....
Complementary Design

Rainier Square shares its site with Rainier Tower, a 40-story office building built in 1977 and designed by Minoru Yamasaki, one of the 20th century's most prominent architects. For this iconic tower, Yamasaki implemented a conspicuous 11-story windowless concrete pedestal that tapers and flares upward and outward like the stem of a wine glass—a safe and resilient structure, to be sure, but one that will forever draw double-takes from passersby in seismically active Seattle.

Given Rainier Tower's revered legacy and unique presence, Rainier Square was designed to preserve, enhance, and pay homage to the older high-rise—not compete with it—by creating a respectful yet visually stunning form that complements and sensitively maintains views and daylight access of Yamasaki's masterpiece.

This goal was achieved via sloping steel columns that afforded Rainier Square its unique, sweeping form. Instead of blocking out Rainier Tower, the new building's east façade curves upward, and the tower's floorplates gradually taper from roughly 34,000 sq. ft to 15,000 sq. ft between levels 4 and 38 to make room for—and lessen the visual impact on—Rainier Tower. Between levels 39 and 58 (the top floor), which house Rainier Square's luxury apartments, the tower's floor plates remain uniform at approximately 15,000 sq. ft per floor. In the end, Rainier Square's signature, curved façade—wide at its base but gradually slimming and tapering as it rises—complements Rainier Tower's own signature, curved pedestal—narrowest at street level but flaring outward and expanding as it rises.



MKA

A low-angle, night-time photograph of the Space Needle tower in Seattle. The tower is illuminated from within, showing its intricate steel lattice structure. The top observation deck is a large, circular, illuminated structure with a grid pattern. The tower tapers as it rises, and the base is a wide, multi-sided platform with a complex steel framework. The background is a solid black, making the illuminated tower stand out prominently.

Steel Space

BY BRIAN MARKHAM, PE,
AND BOB VINCENT

A handful of strategic
steel solutions help
launch the Space Needle
into the future.

opposite page: The Century Project involved updating multiple areas of Seattle's famed Space Needle to address current and future needs.

below: The steel-framed Space Needle under construction in 1961.



Seattle Municipal Archives

SEATTLE'S SPACE NEEDLE has been pointing to the stars for 60 years.

First open to the public on April 21, 1962, for a space age-themed world's fair exposition, the flying saucer-shaped structure challenged modern construction norms to create a new, iconic tower.

And in recent years, the steel-framed, 605-ft-tall symbol for the Emerald City underwent a major renovation, led by Alan Maskin of Seattle-based architecture firm Olson Kundig, that added new elements and necessary seismic upgrades. Dubbed the Century Project, the initiative encompassed the restoration and modernization of the building's 25,000-sq.-ft top house (the occupiable area of the Space Needle)—which starts at the 500-ft level and continues up to the Observation Deck and mechanical levels—while preserving the historic exterior aesthetics and amplifying the observation experience in a way that more closely matches the facility's 1962 concept sketches.

The \$100 million renovation included expanding the observation platform windows for unbroken floor-to-ceiling views; installing a new curved steel sculptural stairway (with steel curved by AISC member bender-roller Albina Co., Inc.) leading from the observation level down to a glass "oculus" on the level below, providing a glimpse of the Needle's superstructure and the ascending and descending elevators; and replacing the original opaque floor with a rotating glass floor called the Loupe. This latter element offers patrons 360° views of the Puget Sound and downtown Seattle and the thrill of being able to see 500 ft straight down as they revolve. In addition to the structural and architectural upgrades, the building also received new MEP and lighting systems, which are hidden within the structural depths. The project also involved updating the structure to meet modern seismic requirements and added 10% more usable public space.

Oculus Stair

Before the Century Project renovation, the three levels of guest areas weren't connected by a publicly accessible staircase and relied solely on elevators. To improve the visitor experience, a new steel-framed elliptical stair connects the 500-ft level to the mezzanine

and observation levels. The stair cantilevers off concealed supports, making it appear to float above the glass floor below. Freeing the elevators from their original circulation burden allowed for greater visitor flow through the space.

The connection of the stair to the surrounding structure was carefully considered to allow the floors of the building to move around it as the building sways in the wind. Under seismic loads, the top connection of the stair incorporates a shear pin that is calibrated to break away, thus protecting the floor framing supporting the stair yet maintaining vertical support for the stair.

To execute the vision of the open stair, large sections of stabilizing floor were cut away. Given the challenges associated with temporarily shoring the floor structure, the construction sequence was designed so that the new W12 primary steel girders that frame the opening could be installed prior to the demolition of the existing girders, incorporating some of the existing framing connections to maintain work points. This approach maintained the stability of the structure through construction without the need for temporary bracing or shoring.

Structural Strengthening

Expanding sightlines and installing a first-of-its-kind rotating glass floor required 176 tons of additional glass. The existing floor trusses were very light, constructed from steel tees and angles, which made them very sensitive to increased loading from the new structural glass. This brought a new set of challenges to ensure the structure could bear the new weight. At the same time, strengthening welds or stiffeners couldn't affect the look of the iconic tower, and renovations had to maintain the recognizable silhouette of the Space Needle on the Seattle skyline. To increase the capacity of the existing structure without drastically changing its profile, steel plates were added to the existing tees, transforming them into wide-flange shapes. New steel for the project, fabricated by AISC member Standard Steel, totaled more than 10,000 parts and pieces. It was critical to minimize additional weight to the top house, as adding too much could have potentially increased the seismic mass and subsequently increased seismic demands.

Arup designed new truss members and connections for the 48 radial trusses supporting the observation deck.

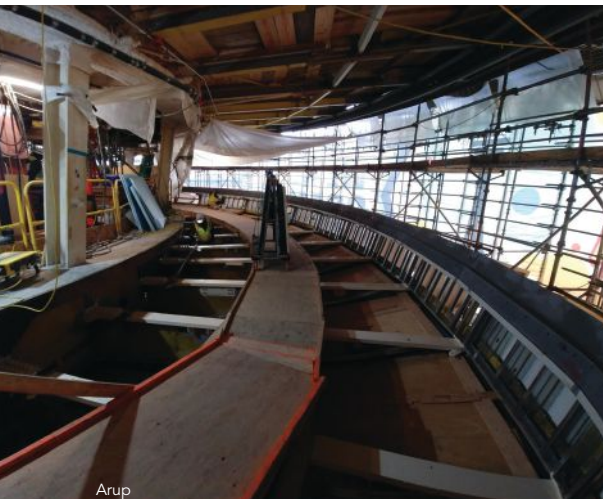

Arup

A new sculptural stairway leads from the observation level down to a glass "oculus" on the level below.



Nic Lehoux

The project brought the Space Needle up to current seismic requirements.

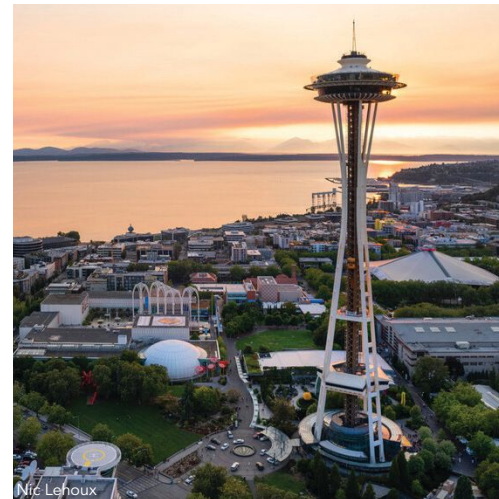

Nic Lehoux

One of the main challenges for the design and construction team was executing the renovation and structural retrofits 500 ft in the air, all while keeping much of the observation deck open to the public. Although all 48 radial trusses that support the observation deck needed to be retrofitted, structural engineer Arup designed the new truss members and connections to be installed around the existing truss to eliminate the need for shoring or tiebacks that would disrupt the building's operation. This meant that after new elements were installed, the construction team could then cut away existing parts of the truss to arrive at the new geometry. New C6 channels were used for the top chords, new HSS5x3 were used for the diagonals, and 1/2-in. by 6-in. plates were added to the existing WT6 bottom chords.

Led by AISC certified erector Apex Steel, the construction sequence minimized disruptions to the observation level, maintaining guest access during the initial installation of the retrofits below. General contractor Hoffman Construction Company could then renovate in sequence, closing only a portion of the observation deck at any time. The erection team used the elevators to bring new steel components to the top. For items that couldn't fit in the elevator, the team employed a davit hoist outside the structure. A single hoist from the ground to the top took about five minutes, and this method was restricted to periods of low wind.

Seismic Retrofit

As expected for a building of its age, many structural connections between existing components required a retrofit. Arup provided seismic upgrades to the top house, where the existing perimeter lateral system was a 100-ft-long concrete shear wall. While the wall itself had sufficient capacity to resist the seismic demands, the top and bottom connections were inadequate and would have required costly retrofit. Three slimmer (1/2-in.-thick) steel plate shear walls were installed in lieu of retrofitting the existing wall, which minimized construction cost and improved access between rooms. With added bracing above public levels and an overall strengthening of lateral connections, the structure was brought up to modern code requirements while upping its seismic resilience.

The Space Needle has always been a symbol of innovation, design, and technology. At the time of its 1962 construction, its futuristic aesthetic pushed the boundaries of design—and its recent renovation will ensure that its legacy will endure for decades to come. ■

To view models of the building systems, sequencing for the new steel flooring system, and additional images of the Space Needle renovation, see the Project Extras section at www.modernsteel.com.

Owner

Space Needle, LLC

Development Manager

Seneca Group

General Contractor

Hoffman Construction Company

Architect

Olson Kundig

Structural Engineer

Arup

Steel Team

Fabricator

Standard Steel Fabricating Company  Seattle

Bender-Roller

Albina Co., Inc.  Tualatin, Ore.



Brian Markham is an associate principal and leads Arup's Seattle office, and **Bob Vincent** is a project manager with Hoffman Construction Company.



new products

This month's New Products section features a faster way to request steel quotes, a sustainably minded building performance-analysis tool, and a headset that keeps construction workers safe and in touch in noisy environments.

FastCAM RFQ

FastCAM RFQ (Request for Quote) enables steel buyers to create detailed quote requests for stock and processed parts, including plate and structural sections. All information is saved in a single electronic file and can be emailed directly to steel vendors for quoting. Import existing CAD files, including CAM, DXF, DWG, NC1 (DSTV), and KISS formats. Cut and paste or enter part data requirements. The software captures true shape geometry from CAD files, including profiling, internal penetrations, beveling, drilled holes, and marking. No need to email separate bill of material listings or attach individual part drawing files. For more information, visit www.fastcam.com/rfq.

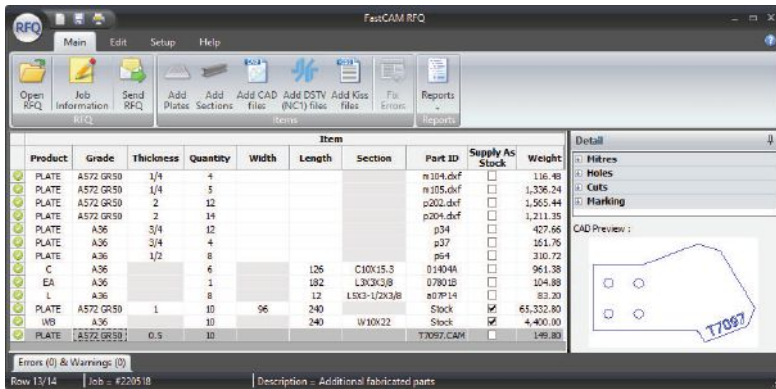

Product	Grade	Thickness	Quantity	Width	Length	Section	Part ID	Supply As Stock	Weight
PLATE	A572 GR50	1/4	4				m304.dxf	<input type="checkbox"/>	116.49
PLATE	A572 GR50	1/4	5				m305.dxf	<input type="checkbox"/>	1,336.24
PLATE	A572 GR50	2	12				p202.dxf	<input type="checkbox"/>	1,565.44
PLATE	A572 GR50	2	14				p204.dxf	<input type="checkbox"/>	1,211.35
PLATE	A36	3/4	12				p34	<input type="checkbox"/>	427.66
PLATE	A36	3/4	4				p37	<input type="checkbox"/>	161.76
PLATE	A36	1/2	8				p54	<input type="checkbox"/>	310.72
C	A36		6		126	C10X15.3	01404A	<input type="checkbox"/>	961.38
EA	A36		1		192	L3X3X3/8	0780B	<input type="checkbox"/>	104.89
L	A36		8		12	L3X3-1/2X3/8	807914	<input type="checkbox"/>	83.20
PLATE	A572 GR50	1	10	96	240		Stock	<input checked="" type="checkbox"/>	65,332.80
WB	A36		10		240	W10X22	Stock	<input checked="" type="checkbox"/>	4,400.00
PLATE	A572 GR50	0.5	10				T7097.CAM	<input type="checkbox"/>	149.80



cove.tool

cove.tool is an automated building performance-analysis assistant that provides holistic insights with features such as daylighting, views, energy analysis, carbon emissions, and cost optimizations—all through a user-friendly, web-based app. Built for the AEC industry, the app helps speed up the design decision process and facilitate better collaboration. With customizable permission levels and an in-app chat feature, all project team members can have concurrent access to critical information, eliminating communication bottlenecks. cove.tool also uses AI to generate thousands of options, providing teams with the best path to a high-performance building with the lowest energy-use intensity (EUI) and the lowest cost premium, which can reduce design revisions and save hundreds of hours per project. For more information, visit www.cove.tools.



Cardo Crew Comm-Set

Comm-Set is a noise-protection communication solution that increases productivity and safety by enabling construction crews to stay connected in noisy and hazardous environments. Powered by Cardo's mesh intercom technology, it can be white-labeled by PPE manufacturers and helps keep boots-on-the-ground teams protected and connected while they work in hazardous environments or remote work sites like construction sites and manufacturing facilities. In addition to connecting anywhere from two to 15 users via wireless mesh technology within a two-mile range, the hands-free set provides situational awareness and is equipped with a plug to easily connect two-way radios. Users can connect their mobile phones via Bluetooth technology and use the dedicated mobile app. For more information, visit www.cardocrew.com.

IN MEMORIAM

Robert “Bob” Lorenz, Former AISC Education Director, Dies at 91

Robert “Bob” Lorenz, who played a major role in expanding AISC’s education efforts in the 1980s and 1990s, died on February 19. He was 91.

Lorenz was born April 2, 1930, in St. Joseph, Mo., where he lived until he graduated from high school. He then enrolled in the Navy ROTC program at Marquette University in Milwaukee, where he received a bachelor’s degree in civil engineering; he also earned a master’s degree from Cornell University. Known as a man of great faith, he was also a proud member of the U.S. Navy, serving from 1951 to 1954 (during the Korean War) on the U.S.S. The Sullivans (DD-537) and rising to the rank of Lieutenant (junior grade).

Lorenz started with AISC as its regional engineer for the Minneapolis area and in 1986, he became director of education, where he expanded AISC’s work with universities and grew the seminar program.

“Bob was the capable and respected face of AISC and our industry for a generation of engineers,” recalled Charles J. Carter, AISC’s president. “He led our annual seminar series, connecting tens of thousands of designers to AISC and engaging many hundreds of speakers from the design community, industry, and academia in the process for more than a decade. His character, kindness, and caring were obvious to all.”

Under Lorenz’s leadership, AISC’s continuing education department worked to promote the long-term growth of structural steel education in universities and colleges, with an emphasis on complementing design education with practical know-how. In 1992, AISC presented its first annual workshop for structural design professors. This two-day workshop was held at ten locations across the country and focused on areas like steel fabrication and erection while also providing educators the opportunity to interact with practicing structural engineers. Lorenz retired from AISC in 2000.

“Bob hired me as assistant director of education of AISC in 1998, and

I worked for him for a couple of years before he retired,” recalled Steve Ashton, engineering manager with Blue-Scope. “The years I worked with him were the best of my career. He was an excellent teacher and storyteller. He not only prepared me for a career in the steel industry, but he also taught me a lot about traveling, business, and life in general.”

“I have much to thank Bob for, as he is the one that really introduced me to AISC,” recalled James M. Fisher, emeritus vice president of CSD Structural Engineers. “I once told him that AISC should put on a lecture series on industrial buildings. Before I knew it, he had arranged a meeting with Bob Disque and Bill Milek to discuss the topic in my office. I ended up giving lectures in 54 cities during a two-year period, more than one-third of these with Bob.”

“He commuted to Chicago from Milwaukee on the 6:30 a.m. train every day. I made several trips on the train with him, and he always worked the entire 90-minute trip on engineering problems or creating new lecture series. Once arriving in Chicago, he would go to church to pray before heading off to the office.”

Lorenz is survived by Rita, wife of 65 years; children Dan, Jane, Mary Ellen (deceased), and Paul (deceased); grandchildren Maggie, Sarah, and Veronica; and four great-grandchildren.



People & Companies

John D. Hooper, SE, PE, a senior principal at **Magnusson Klemencic Associates (MKA)** and the firm’s director of earthquake engineering, has been elected to the **National Academy of Engineering (NAE)**. Hooper was recognized for the advancement of building code seismic design provisions and earthquake-resistant structural design of major buildings around the world. **Northeastern University department chair and CDM Smith Professor of Civil and Environmental Engineering Jerome Hajjar, PE, PhD**, was also elected to the NAE for his development of design criteria and models for stability and seismic design of innovative steel and composite structures. According to the NAE, elected members are recognized for their “outstanding contributions to engineering research, practice, or education, including, where appropriate, significant contributions to the engineering literature,” as well as for pioneering “new and developing fields of technology, making major advancements in traditional fields of engineering, or developing/implementing innovative approaches to engineering education.”

Kyle MacDonald has recently advanced to the level of associate at **Severud Associates**. He began at the company in 2016 as an engineer and progressed to senior engineer four years later.

The **American Iron and Steel Institute (AISI) Steel Bridge Task Force, NSBA**, and the **American Association of State and Highway Transportation Officials (AASHTO)** T-14 Technical Committee for Structural Steel Design have named **Todd Helwig, PhD**, director of the Ferguson Structural Engineering Laboratory and professor of engineering at the University of Texas at Austin, as the recipient of the 2022 Richard S. Fountain Award.

Multidiscipline engineering firm **Coffman Engineers, Inc.**, announced the opening of its Houston area in The Woodlands, Texas. The new location allows the firm to support clients in the industrial, oil and gas, healthcare, federal/military, higher education, hospitality, and energy markets.

SAFETY AISC Announces 2021 Safety Award Winners

More than 70 structural steel facilities are being honored with AISC Safety Awards for their excellent records of safety performance in 2021. Awards are given in the categories of “Fabricator” and “Erector” and include the Safety Award of Honor—AISC’s top safety award, presented for a perfect safety record of no disabling injuries—as well as the Safety Award of Merit and Safety Commendation.

“AISC’s annual Safety Awards program recognizes excellent records of safety performance, and we commend these facilities for their effective accident prevention programs,” said Tom Schlafly, AISC’s director of safety. “Periodic recognition of safety in

the workplace has been demonstrated to provide worker incentive and a reminder of the importance of safe practices.”

All AISC full fabricator members and erector associate members are eligible and asked to participate, and data for the program is solicited annually. In order to facilitate data collection and to make statistics meaningful in terms familiar to safety professionals, the program uses data that companies also report to OSHA. The program recognizes performance measured in terms of Days Away, Restricted or Transferred Rate (DART). The DART is a measure of the number of recordable lost work cases

per 200,000 hours worked. Only the number of cases (not days) that are required to be reported on the OSHA 300A form and that cause a lost work day as defined by OSHA are reported to AISC, along with the hours worked in the year. AISC Safety Awards are given for perfect records (Honor, $0 < \text{DART} \leq 0$), excellent records (Merit, $0 < \text{DART} \leq 1$), and commendable records (Commendation, $1 < \text{DART} \leq 2$).

For more information about the program as well as safety resources available to the fabricated and erected structural steel industry, please visit aisc.org/safety. Here are the winners:



Fabricator Honor Award

Associated Steel Fabricators, Inc.
Ben Hur Steel Worx, LLC
BENCHMARK Fabricated Steel
Center Point Contractors, Inc.
Champion Bridge Company
Covenant Steel Warehouse, Inc.
Custom Metals, a Division of Lexicon, Inc.
Design Build Structures, LLC
Dixie Southern Industrial, Inc.
Douglas Steel Fabricating Corporation
East Coast Metal Structures, Corp.
Eddy’s Welding, Inc.
F.A. Wilhelm Construction Co. Inc.
Gayle Manufacturing Company
Geiger & Peters, Inc.
George’s Welding Services, Inc.
Gerace Construction Co., Inc.
Industrial Resources, Inc.
J.R. Hoe and Sons
Kienlen Constructors
Larwel Industries
Lyndon Steel Company
Maccabee Industrial Inc.
McPeak Supply, LLC
Mike Owen Fabrication, Inc.
Miscellaneous Steel Industries, Inc.
Mobil Steel International, Inc.
Newport Industrial Fabrication, Inc.
NOVA Group, Inc.
PAX, LLC.
Phoenix Fabrication & Supply, Inc.
Pikes Peak Steel LLC
Prospect Steel, a Division of Lexicon, Inc.

RCC Fabricators, Inc.

Rens Welding & Fabricating, Inc.
Rochester Rigging & Erectors, Inc.
Rochester Structural, LLC
Schuff Steel Midwest
Scott Steel Services, Inc.
Shure Line Construction
Southwest Steel LLC
Steel Service Corporation
Steel Specialty, Inc.
Structural Steel & Plate Fabrication, Co.
Systems Fab & Machine, Inc.
The Arthur Louis Steel Company
The Gateway Company of Missouri LLC
The Haskell Company
TrueNorth Steel
Twin Brothers Marine, LLC
United Weld Services, LLC
Universal Steel of NC, LLC
Western Slope Iron & Supply, Inc.
Zimkor LLC

Erector Honor Award

Diversified Metalworks
Dixie Southern Industrial, Inc.
East Coast Metal Structures, Corp.
F.A. Wilhelm Construction Co. Inc.
Ideal Contracting
Kienlen Constructors
National Steel City, LLC
North Alabama Fabricating Company, Inc.
Rens Welding & Fabricating, Inc.
ROC Steel, LLC
Rochester Structural, LLC
Shure Line Construction
Systems Fab & Machine, Inc.
The Arthur Louis Steel Company
United Weld Services, LLC



Fabricator Merit Award

Corebrace, LLC
DIS-TRAN Steel, LLC
Jesse Engineering Company
Metal Pros, LLC
North Alabama Fabricating Company, Inc.
Prospect Steel, a Division of Lexicon, Inc.
Schuff Steel Company
SME Steel Contractors, Inc.
Transco Ind., Inc.
Veritas Steel

Erector Merit Award

Ben Hur Steel Worx, LLC
Derr Steel Erection Co.
SME Steel Contractors, Inc.
Southwest Steel LLC



Fabricator Safety Commendation

Ford Steel, LLC
Johnson Machine Works, Inc.
JPW Structural Contracting, Inc.
Padgett, Inc.
Schuff Steel Company
Steel Fabricators of Monroe
Steward Steel, Inc.

Erector Safety Commendation

Padgett, Inc.

AWARDS

AISC Announces 15 Award Recipients for 2022

Virginia Tech's Roberto T. Leon, PE, PhD, Michigan-based designer David I. Ruby, SE, PE, and UC Davis' Amit Kanvinde head a distinguished list of 2022 award recipients from AISC.

"AISC's awards program honors individuals who have made a difference in the success of the fabricated structural steel industry," said AISC's president, Charles J. Carter, SE, PE, PhD. "I've had the pleasure of knowing and working with many of these amazing individuals, and I'm proud and excited to be able to present their awards at this year's NASCC: The Steel Conference in Denver, March 23–25."

The Geerhard Haaijer Award for Excellence in Education

*Roberto T. Leon, PE, PhD, D.H. Burrows
Professor of Construction Engineering,
Virginia Tech*



AISC's highest honor for educators, the Haaijer Award honors individuals for both their research and teaching. Leon is honored for his nearly 40 years of teaching, research, and professional leadership. He is internationally recognized for his work in seismic behavior and design of composite and hybrid steel-concrete structures, composite action in beam-slab systems, testing of full-scale and model structures in the laboratory, and field instrumentation of structures. He also has served as chair of AISC's Composite Construction task committee and is a member of the AISC Committee on Specifications. He has previously won the AISC T. R. Higgins Lectureship Award, the AISC Special Achievement Award, the AISC Lifetime Achievement Award, been elected a Distinguished Member of ASCE and elected a Fellow within ASCE, SEI, and ACI, the ASCE Norman Medal, the ASCE State-of-the-Art award on two occasions, the ASCE Tewksbury Award, ASCE Presidents Award.

The J. Lloyd Kimbrough Award

*David I. Ruby, SE, PE, founding principal,
Ruby + Associates*



As AISC's highest honor for designers, the Kimbrough Award honors engineers and architects who are universally recognized as the preeminent steel designers of their era. Ruby is nationally recognized for his work on erection and stability analysis, value-engineering, and constructability-focused design. He's the author of AISC's Design Guide 23: *Constructability for Structural Steel Buildings* and one of the most popular speakers at the annual NASCC: The Steel Conference. He won an AISC Lifetime Achievement Award in 2011 and the ACEC/Michigan Felix A. Anderson Award in 2019. He has served as the chair of the Council of American Structural Engineers, a past director of the National Council of Structural Engineers Association, past president of the Structural Engineers Association of Michigan, and a member of AISC's Code of Standard Practice Committee, Committee on Research, and was past co-chair of the Blast & Impact Resistant Design Task Group.

T.R. Higgins Lectureship Award

*Amit Kanvinde, PhD, professor of
civil and environmental engineering at
University of California, Davis*

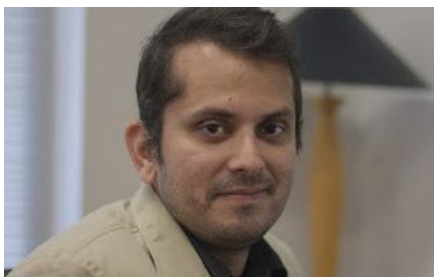

Widely recognized for his work in the behavior, design, and structural interactions of various types of connections, including exposed, slab-overtopped, and embedded

connections, Kanvinde will present his paper, "Column Base Connections: Research, Design, and a Look to the Future," at this year's NASCC: The Steel Conference. He currently serves on the AISC Connection Prequalification Review Panel (CPRP) and the Committee on Research. He previously received AISC's Special Achievement Award (2017) and the Norman Medal (2008), Walter Huber Research Prize (2016), and the State of the Art of Civil Engineering Award (2018), all from the American Society of Civil Engineers.

Milek Fellowship

*Kara Peterman, PhD,
University of Massachusetts, Amherst*



AISC has chosen to award, based on a recommendation from our Committee on Research, Kara Peterman of the University of Massachusetts-Amherst the 2022 Milek Fellowship for her proposal titled, "Holistic Design and Behavior of Adhesive Steel-to-Steel Connections."

Her proposed research will provide the fundamental knowledge needed to enable adhesive steel-to-steel connections in slip-critical bolted connections, prefabricated modular construction, bridge girder splices, and anchorage. Several aspects of utilizing adhesives in steel structures will be investigated, including installation procedure, structural behavior, creep performance, and performance under elevated temperatures. A large suite of experimental testing will be conducted, beginning with base material testing leading to connection level and sub-system testing. The experimental program will culminate in sub-system testing, ranging from the adhesive as the primary connecting element to the secondary connecting element. Design recommendations will be developed that provide clear guidance on selecting and designing with a structural adhesive. In addition to the recommendations and experimental data, this project will create a centralized and searchable database of

AWARDS

AISC Announces 15 Award Recipients for 2022 (cont'd.)

available structural adhesives for use by the structural steel community.

Peterman is an assistant professor of civil engineering at the University of Massachusetts-Amherst, where she has worked since 2016. Before her current position, she worked as a postdoctoral research associate at Northeastern University. She earned her PhD and master's degrees in structural engineering from Johns Hopkins University and her bachelor's degree in engineering from Swarthmore College. Peterman's current research interests include experimental and analytical behavior of cold-formed and hot-rolled steel structures, full-scale experimentation, and creating and implementing sustainable design methods. She is also active in various STEM outreach activities and is an accomplished musician.

Lifetime Achievement Awards honor living individuals who have made a difference in the success of AISC and the structural steel industry.

*Todd A. Helwig, PE, PhD, professor,
University of Texas at Austin*

Recognized for significant contributions over many years to the advancement of design for structural stability with particular focus on bracing requirements (specification and design implementation); steel bridge research; and university education and continuing education related to steel design with a focus on bridge engineering and stability.

*Robert Tremblay, PEng, PhD, professor,
Polytechnique Montréal*

Recognized for significant contributions over many years to the advancement of seismic design of steel structures, including research on concentrically and eccentrically braced frames, controlled rocking systems, and bolted connections, and for his significant role in international collaborations for the development of steel design standards.

*Grady E. Harvell, PE, president, & COO,
W&W/AFCO Steel*

Recognized for his drive to fund research to make steel bridges more economical, his commitment to steel bridge education, and his contributions to the National Steel Bridge Alliance.

*Allen Adams, SE, PE, chief structural
engineer, Bentley Systems*

Recognized for his contribution to the development of the RAM Structural System, his drive to improve the accuracy and speed with which steel buildings are designed, and his service on AISC committees.

*D. Kirk Harman, SE, PE, president/
managing principal, The Harman Group*

Recognized for his contributions to the AISC *Code of Standard Practice*, his guidance on BIM and alternative delivery methods, his work designing award-winning steel buildings, and his many presentations at NASCC: The Steel Conference.

Special Achievement Awards provide special recognition to individuals (industry members, designers, or educators) who have demonstrated notable singular or multiple achievements in structural steel design, construction, research, or education.

*Gian Andrea Rassati, PhD, and
James Swanson, PhD, associate professors,
University of Cincinnati*

Recognized for their research on the behavior and design of bolted steel connections and their major contributions to the latest national design specifications for high-strength steel bolts (*RCSC Specification*).

*Susan Burmeister, SE, PE, president, S2B
Structural Consultants and Larry Kloiber, PE,
consultant, LeJeune Steel*

Recognized for contributions to the advancement of fabricated structural steel

through the writing of AISC's Design Guide 36: *Design Considerations for Camber*.

Terry Peshia Early Career Faculty Awards provide recognition to individuals who are on a tenure track or have received tenure within the last three years and who demonstrate promise in structural steel research or teaching and/or have made other contributions to the structural steel industry.

*Rachel Chicchi Cross, SE, PE, PhD, assistant
professor, University of Cincinnati*

As an assistant professor at the University of Cincinnati since 2018, Chicchi has the advantage of being able to combine years of practical experience with her solid academic background. Her interests in steel research are forward-looking, especially when considering her focus on research on practical applications of high strength steels for building applications and her expertise in fire conditions, which led her to be an active participant in AISC Task Committee 8 (TC 8) – Design for Fire Conditions and in Task Committee 2 – Editorial, Economy, Efficiency, & Practical Use as the TC 8 liaison.

*Ryan Sherman, PE, PhD, assistant professor,
Georgia Institute of Technology*

An assistant professor at Georgia Tech since 2019 and an assistant professor at UNLV from 2016 to 2019, Sherman has a range of steel building, bridge, and ancillary highway structure research experience, including large-scale structural testing, field monitoring, material characterization, and FEA simulation. His recent research explores the areas of metallic additive manufacturing, high-toughness steel fracture performance, and stability limit states of built-up I-section members. His work in the steel industry offers the potential to optimize structural performance, integrate design and inspection strategies, and streamline design processes, resulting in more efficient steel structures.

AISC

AISC Announces New VPs of Membership and Certification, Finance and Human Resources

AISC has named Todd Alwood its new vice president of membership and certification and promoted Michael Mospan to vice president of finance and human resources.

Alwood joined AISC in 2002 as a senior advisor with the Steel Solutions Center, eventually became a regional engineer for the Upper Midwest, and in 2011 moved to the certification department.

Mospan joined AISC in 2018 as director of finance after a long career in financial services at companies such as Deloitte, the Chicago Tribune, and Filter Services, Inc.

BRIDGES

American Steel Bridge Industry Ready and Able to Meet Nation's Infrastructure Needs

"We're excited that funding is finally becoming available to rejuvenate and improve America's bridges," stated Charles J. Carter, SE, PE, PhD, president of AISC and executive director of the National Steel Bridge Alliance. The American steel fabrication industry and our domestic steel mills are ready and able to meet our nation's infrastructure needs."

Carter discussed the current state of the fabrication industry during a special session at this year's NASCC: The Steel Conference, which took place in Denver in March. "Last summer, as a result of the ongoing pandemic, the structural steel industry experienced longer than normal lead times and extended delivery schedules, just like almost every construction material,"

Carter explained. "Fortunately, the steel industry has almost fully recovered. And whether it's raw steel or fabricated product, our members have the personnel, capacity, experience, and skill to successfully complete all of the anticipated projects."

Thanks to Buy America provisions, steel plate and structural steel used in bridge construction are widely available from domestic steel mills and are therefore not subject to the current port delays most supply chains are currently experiencing. Further, to accommodate the expected increased demand from the recently passed infrastructure bill, the steel industry is rapidly adding capacity, such as the \$1.7 billion plate mill now under construction in Kentucky and additional upgrades

being made by multiple steel producers. According to steel mill representatives, the industry has the capacity to support both the current and expected future demand for steel. And on the fabrication side, many companies have upgraded their equipment, improved their automation, and increased their staffing in anticipation of increased bridge projects due to the new infrastructure bill.

While availability and lead times were the hot topics last fall, today's discussions focus more on the escalated pricing for all raw materials. John O'Quinn, president of High Steel Structures and chair of NSBA's Market Development Committee, is quick to point out that raw material pricing represents only a fraction of the total cost of a bridge.

"You cannot simply look at the change in plate pricing to fully gauge the cost of a bridge," he explained. "We manage highly impactful variables including labor, materials, coating systems, erection, and even the timing of the project to best deliver bridges at a cost and schedule that meets each owner and project's needs."

Owners and designers with specific concerns about pricing and availability should contact either their regional NSBA representative (visit aisc.org/nsba for contact information) or one of AISC's more than 350 certified steel bridge fabricators (for a complete list, visit aisc.org/certification).



BRIDGES

NSBA Releases New Steel Bridge Design Handbook

A newly updated and fully revised edition of the *Steel Bridge Design Handbook* (formerly the *Highway Structures Design Handbook*) is now available as a free download from the National Steel Bridge Alliance (NSBA), a division of AISC.

"Since it was first introduced by US Steel in the 1970s, the *Handbook* has been a popular and important reference for everyone involved in the design and construction of steel bridges," notes Jeff Carlson, PE, director of market development for NSBA. "It includes the latest research and advice from the nation's top bridge experts and includes

information ranging from mechanical properties of steel to splice design to corrosion protection."

The original *Handbook* was produced by US Steel in the 1970s and quickly became a popular reference for steel bridge design. Later editions were produced by AISC and authored by FHWA, NSBA, and HDR Engineering.

This current edition of the *Handbook* will be maintained by NSBA. It includes 19 chapters and six design examples, all in PDF format and downloadable at aisc.org/bridgehandbook.

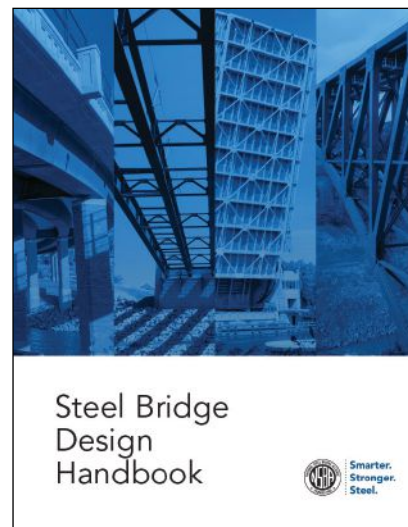



SMITH-EMERY

Inspection • Testing • Metallurgy

Assuring Structure & Life Safety Since 1904

Non-Destructive Testing

- PAUT
- Visual (CWI, CWB, CSWIP)
- MT
- UT

Owner QA

- Fabrication Oversight
- Specification Review
- Field Inspections
- WPS Reviews

Metallurgical Laboratory
Environmental Laboratory
Firestop Inspection

Supplier Audits

- IAS
- IAPMO
- City of Los Angeles
- Clark County, NV

Contractor QC

- Fabrication Shop NDT, CWI
- Vendor Audits
- QMS Development
- WPS and PQR Testing

Curtain Wall Performance Testing
Concrete Testing
Chemical Laboratory

1.833.405.0536
 steel@smithemery.com
 www.smithemery.com



Connect with AISC on
SOCIAL MEDIA

- aisc.org/linkedin
- @AISC
- AISCdotORG
- @AISC
- youtube.com/AISCSteelTV

Structural Engineers

Are you looking for a new and exciting opportunity?

We are a niche recruiter that specializes in matching great structural engineers with unique opportunities that will help you utilize your talents and achieve your goals.

- We are structural engineers by background and enjoy helping other structural engineers find their "Dream Jobs."
- We have over 30 years of experience working with structural engineers.
- We will save you time in your job search and provide additional information and help during the process of finding a new job.
- For Current Openings, please visit our website and select Hot Jobs.
- Please call or email Brian Quinn, PE: 616.546.9420 **Brian.Quinn@FindYourEngineer.com** so we can learn more about your goals and interests. *All inquiries are kept confidential.*

SE Impact by SE Solutions, LLC | www.FindYourEngineer.com

LATE MODEL STRUCTURAL STEEL MACHINES AVAILABLE IMMEDIATELY

- Peddinghaus PCD-1100** Drill & Saw Line, 44" x 18" Capacity, (3) Spindle, Meba 1140/510 Saw, Siemens CNC, In/Out Conveyor, 2006, #31842
- Peddinghaus AFCPS 823-B** Anglemaster, 8" x 8" x 3/4" Capacity, Infeed Conveyor, PC Based CNC, 2006, #31841
- Peddinghaus HSFDB 2500/B** Plate Processor, 3" Plate, 96" Maximum Plate Width, HPR400XD Plasma, Drill, Oxy, 2015, #31660
- PythonX** Robotic Plasma Cutting System, 3-Sided, HPR 400 Plasma, Infeed & Outfeed Conveyor, 2010, #31748
- Peddinghaus PCD-1100** Drill, (3) Spindle, 44" x 18" Capacity, 850 RPM, Siemens CNC, 2006, #31654
- Peddinghaus ABCM-1250A** Beam Coping Line, 50" x 24" Maximum Profile, Fagor 8055 Retrofit, #31655
- Voortman V630/1000** CNC Drill Line, (3) Drill Units, ATC, VB1050 20" x 44" Saw, Conveyor & Transfers, 2006, #31801



WE ARE ACTIVELY LOOKING FOR USED STRUCTURAL STEEL EQUIPMENT
 CONTACT: Claire@PrestigeEquipment.com

www.PrestigeEquipment.com | (631) 249-5566

To advertise, contact M.J. Mrvica Associates, Inc.: 856.768.9360 | mjmrvica@mrvica.com. Search employment ads online at www.modernsteel.com.

advertiser index

AISC	8 15 67	Peddinghaus Corporation	2
Automated Layout Technology	21	QuickFrames USA	45
Cast Connex	12	SDS2	7
Chicago Metal Rolled Products	26-27	St. Louis Screw & Bolt	45
FICEP	13	Trimble	3
IDEA Statica	14	Voortman	25
IMPACT	11	Zekelman Industries	5
Locomotion	68		



Happy Trails

THE MICHAEL AND QUIRSIS RINEY Primate Canopy Trails weave weathering steel with nature in an interactive outdoor primate exhibit at the Saint Louis Zoo.

Designed by architect PGAV Destinations and structural engineer Leigh and O’Kane, the 35,000-sq.-ft exhibit includes multiple steel elements in eight different primate habitats. AISC members The Gateway Company of Missouri and Acme Erectors fabricated and erected the steel, respectively, with AISC member bender-roller Max Weiss Company providing

curving services for the various round hollow structural sections (HSS).

Steel climbing structures are intertwined with live trees, and a winding boardwalk made of curved steel allows visitors a treetop view throughout the exhibit. Using a combination of painted and weathering steel provided two benefits: It offered a solution for addressing conditions in an outdoor environment, and it provided a more natural forest look that the architect and design team desired. In the three largest habitats, painted round HSS assemblies are

interwoven between sycamore and blue ash trees to create additional climbing and enrichment activities for the animals. Above these, suspended high in the treetops, round HSS made from weathering steel supports netting that encloses the habitats. In addition, 16 weathering steel shelter boxes are spread throughout the habitats. These assemblies provide the animals with shade in the summer, cover during the rain, and a place to simply hang out when they’re not swinging around the surrounding trees, either real or steel. ■

Better Together

Bone up on steel design with your very own copies of the
15th Edition *Steel Construction Manual* and the
3rd Edition *Seismic Design Manual*

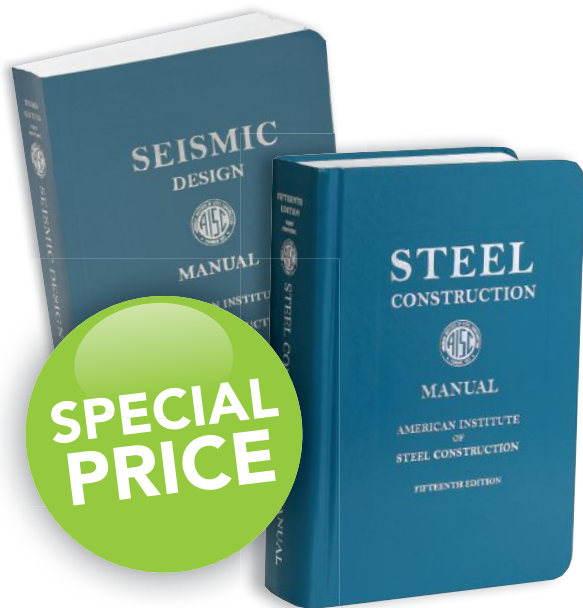

Learn more about these great AISC steel design resources
at aisc.org/manualresources and aisc.org/seismic.

ORDER YOUR SET TODAY!
aisc.org/publications | 800.644.2400



Smarter. Stronger. Steel.

American Institute of Steel Construction
312.670.2400 | www.aisc.org

Follow the leaders *to safety*

The success of business often hinges on the strength of the partnerships forged along the way.

That is why we're proud to announce the partnership of PGT Trucking + Locomotion to deliver the future of freight transportation.

When you bring together a leader in the flatbed transportation industry with the leader in human-guided automated trucking technology, well, you end up with a pretty strong bond. Together, PGT + Locomotion are leading the way to increased efficiency, more capacity, elevated safety, and a greener footprint. Better for drivers, better for the earth, and better for your bottom line.

Start your journey
to safety.

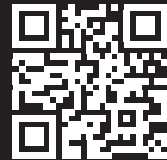

Follow the leaders



+

LOCOMOTION
human-guided autonomy[®]

